



Shenzhen CTL Testing Technology Co., Ltd.
Tel: +86-755-89486194 E-mail: ctl@ctl-lab.com

TEST REPORT

ETSI EN 300 328 V2.2.2 (2019-07)

Report Reference No. : CTL2104203011-WR

Compiled by: Happy Guo
(position+printed name+signature) (File administrators)

Tested by: Gary Gao
(position+printed name+signature) (Test Engineer)

Approved by: Ivan Xie
(position+printed name+signature) (Manager)



Product Name : Bluetooth Speaker

Model/Type reference : Tronsmart Element Mega

List Model(s)..... : N/A

Trade Mark..... : Tronsmart

Applicant's name : Shenzhen Geekbuy E-commerce Co., Ltd.

Address of applicant : 19th Floor, Galaxy World Tower B, #1 YaBao Rd., LongGang District, Shenzhen, China

Test Firm..... : Shenzhen CTL Testing Technology Co., Ltd.

Address of Test Firm : Floor 1-A, Baisha Technology Park, No.3011, Shahehexi Road, Nanshan District, Shenzhen, China 518055

Test specification..... :

Standard : ETSI EN 300 328 V2.2.2 (2019-07)

TRF Originator : Shenzhen CTL Testing Technology Co., Ltd.

Master TRF..... : Dated 2011-01

Date of receipt of test item : Apr. 26, 2021

Date of sampling..... : Apr. 26, 2021

Date of Test Date..... : Apr. 26, 2021 - May. 10, 2021

Date of Issue : May. 11, 2021

Result..... : Pass

Shenzhen CTL Testing Technology Co., Ltd. All rights reserved.

This publication may be reproduced in whole or in part for non-commercial purposes as long as the Shenzhen CTL Testing Technology Co., Ltd. is acknowledged as copyright owner and source of the material. Shenzhen CTL Testing Technology Co., Ltd. takes no responsibility for and will not assume liability for damages resulting from the reader's interpretation of the reproduced material due to its placement and context.

TEST REPORT

Test Report No. :	CTL2104203011-WR	May. 11, 2021
		Date of issue

Equipment under Test : Bluetooth Speaker

Sample No. CTL210420301-1-S001

Model /Type : Tronsmart Element Mega

Listed Models : N/A

Applicant : **Shenzhen Geekbuy E-commerce Co., Ltd.**

Address : 19th Floor, Galaxy World Tower B, #1 YaBao Rd.,
LongGang District, Shenzhen, China

Manufacturer : **Shenzhen Geekbuy E-commerce Co., Ltd.**

Address : 19th Floor, Galaxy World Tower B, #1 YaBao Rd.,
LongGang District, Shenzhen, China

Test result	Pass *
--------------------	---------------

* In the configuration tested, the EUT complied with the standards specified page 5.

The test results presented in this report relate only to the object tested.

This report shall not be reproduced, except in full, without the written approval of the issuing testing laboratory.

Contents

1	TEST SUMMARY	5
1.1	TEST STANDARDS.....	5
1.2	TEST DESCRIPTION.....	5
1.3	TEST FACILITY	6
1.4	STATEMENT OF THE MEASUREMENT UNCERTAINTY.....	6
2	GENERAL INFORMATION	8
2.1	ENVIRONMENTAL CONDITIONS	8
2.2	GENERAL DESCRIPTION OF EUT	8
2.3	RECEIVER CATEGORIES	8
2.4	DESCRIPTION OF TEST MODES AND TEST FREQUENCY.....	9
2.5	MEASUREMENT INSTRUMENTS LIST	9
3	TEST ITEM AND RESULTS	11
3.1	RF OUTPUT POWER	11
3.2	DUTY CYCLE, TX-SEQUENCE, TX-GAP.....	13
3.3	ACCUMULATED TRANSMIT TIME, FREQUENCY OCCUPATION AND HOPPING SEQUENCE	14
3.4	HOPPING FREQUENCY SEPARATION	16
3.5	MEDIUM UTILISATION (MU) FACTOR.....	17
3.6	OCCUPIED CHANNEL BANDWIDTH	18
3.7	TRANSMITTER UNWANTED EMISSIONS IN THE OUT-OF-BAND DOMAIN	19
3.8	TRANSMITTER UNWANTED EMISSIONS IN THE SPURIOUS DOMAIN.....	20
3.9	RECEIVER SPURIOUS EMISSIONS.....	24
3.10	ADAPTIVITY.....	27
3.11	RECEIVER BLOCKING	29
4	TEST SETUP PHOTOS OF THE EUT	33
5	EXTERNAL AND INTERNAL PHOTOS OF THE EUT.....	34
6	ANNEX E.....	35

1 TEST SUMMARY

1.1 Test Standards

The tests were performed according to following standards:

ETSI EN 300 328 V2.2.2 (2019-07)–Wideband transmission systems; Data transmission equipment operating in the 2,4 GHz ISM band and using wide band modulation techniques; Harmonised Standard for access to radio spectrum

1.2 Test Description

Item	Reference	Result
Maximum transmit power	ETSI EN 300 328 (V2.2.2) Sub-clause 4.3.1.2	PASS
Duty Cycle, Tx-sequence, Tx-gap	ETSI EN 300 328 (V2.2.2) Sub-clause 4.3.1.3	N/A _{note1}
Dwell time, Minimum Frequency Occupation and Hopping Sequence	ETSI EN 300 328 (V2.2.2) Sub-clause 4.3.1.4	PASS
Hopping Frequency Separation	ETSI EN 300 328 (V2.2.2) Sub-clause 4.3.1.5	PASS
Medium Utilisation (MU) factor	ETSI EN 300 328 (V2.2.2) Sub-clause 4.3.1.6	N/A _{note1}
Adaptively	ETSI EN 300 328 (V2.2.2) Sub-clause 4.3.1.7	N/A _{note2}
Occupied Channel Bandwidth	ETSI EN 300 328 (V2.2.2) Sub-clause 4.3.1.8	PASS
Transmitter unwanted emissions in the out-of-band domain	ETSI EN 300 328 (V2.2.2) Sub-clause 4.3.1.9	PASS
Transmitter unwanted emissions in the spurious domain	ETSI EN 300 328 (V2.2.2) Sub-clause 4.3.1.10	PASS
Receiver spurious emissions	ETSI EN 300 328 (V2.2.2) Sub-clause 4.3.1.11	PASS
Receiver Blocking	ETSI EN 300 328 (V2.2.2) Sub-clause 4.3.1.12	PASS
Geo-location capability	ETSI EN 300 328 (V2.2.2) Sub-clause 4.3.1.13	N/A _{note3}

Note1: This requirement does not apply to adaptive equipment.

Note2: Which is not applicable to device with a maximum RF Output power level is less than 10 dBm e.i.r.p.

Note3: This equipment without geo-location capability function.

1.3 Test Facility

1.3.1 Address of the test laboratory

Shenzhen CTL Testing Technology Co., Ltd.

Floor 1-A, Baisha Technology Park, No. 3011, Shahexi Road, Nanshan, Shenzhen 518055 China

There is one 3m semi-anechoic chamber and two line conducted labs for final test. The Test Sites meet the requirements in documents ANSI C63.4 and CISPR 32/EN 55032 requirements.

1.3.2 Laboratory accreditation

The test facility is recognized, certified, or accredited by the following organizations:

CNAS-Lab Code: L7497

Shenzhen CTL Testing Technology Co., Ltd. has been assessed and proved to be in compliance with CNAS-CL01 Accreditation Criteria for Testing and Calibration Laboratories (identical to ISO/IEC 17025: 2005 General Requirements) for the Competence of Testing and Calibration Laboratories.

A2LA-Lab Cert. No. 4343.01

Shenzhen CTL Testing Technology Co., Ltd. EMC Laboratory has been accredited by A2LA for technical competence in the field of electrical testing, and proved to be in compliance with ISO/IEC 17025: 2005 General Requirements for the Competence of Testing and Calibration Laboratories and any additional program requirements in the identified field of testing.

IC Registration No.: 9618B

CAB identifier: CN0041

The 3m alternate test site of Shenzhen CTL Testing Technology Co., Ltd. EMC Laboratory has been registered by Innovation, Science and Economic Development Canada to test to Canadian radio equipment requirements with Registration No.: 9618B on Jan. 22, 2019.

FCC-Registration No.: 399832

Designation No.: CN1216

Shenzhen CTL Testing Technology Co., Ltd. EMC Laboratory has been registered and fully described in a report filed with the (FCC) Federal Communications Commission. The acceptance letter from the FCC is maintained in our files. Registration 399832, December 08, 2017.

1.4 Statement of the measurement uncertainty

The data and results referenced in this document are true and accurate. The reader is cautioned that there may be errors within the calibration limits of the equipment and facilities. The measurement uncertainty was calculated for all measurements listed in this test report acc. to CISPR 16 - 4 „Specification for radio disturbance and immunity measuring apparatus and methods – Part 4: Uncertainty in EMC Measurements“ and is documented in the Shenzhen CTL Testing Technology Co., Ltd. quality system acc. to DIN EN ISO/IEC 17025. Furthermore, component and process variability of devices similar to that tested may result in additional deviation. The manufacturer has the sole responsibility of continued compliance of the device.

Hereafter the best measurement capability for CTL laboratory is reported:

Test Items	Measurement Uncertainty	Notes
Occupied Channel Bandwidth	±2%	(1)
Transmitter power conducted	0.57 dB	(1)
Transmitter power Radiated	2.20 dB	(1)
Conducted spurious emission	1.60 dB	(1)
Radiated spurious emission	2.20 dB	(1)
Temperature	±1°C	(1)

Humidity	$\pm 3\%$	(1)
DC and low frequency voltages	$\pm 1.5\%$	(1)
Time	$\pm 2\%$	(1)
Duty cycle	$\pm 2\%$	(1)

Note 1: This uncertainty represents an expanded uncertainty expressed at approximately the 95% confidence level using a coverage factor of $k=1.96$.

2 GENERAL INFORMATION

2.1 Environmental conditions

During the measurement the environmental conditions were within the listed ranges:

Temperature	Normal Temperature:	25°C
	High Temperature:	55°C
	Low Temperature:	-20°C
Voltage	Normal Voltage	7.40V
	High Voltage	8.14V
	Low Voltage	6.66V
Other	Relative Humidity	55 %
	Air Pressure	101 kPa

2.2 General Description of EUT

Product Name:	Bluetooth Speaker
Model/Type reference:	Tronsmart Element Mega
Power supply:	DC 7.4V from battery
Bluetooth:	
Version:	Supported BR/EDR
Modulation:	GFSK, $\pi/4$ DQPSK, 8DPSK
Operation frequency:	2402MHz~2480MHz
Channel number:	79
Channel separation:	1MHz
Antenna type:	PCB Antenna
Antenna gain:	0dBi

Note 1: For more detailed features description, please refer to the manufacturer's specifications or the User's Manual.

2.3 Receiver categories

This device belongs to the receiver categories as the choice box selected:

	Categorization	Note
<input type="checkbox"/>	Receiver category 1	Adaptive equipment with a maximum RF output power greater than 10 dBm e.i.r.p.
<input checked="" type="checkbox"/>	Receiver category 2	Non-adaptive equipment with a Medium Utilization (MU) factor greater than 1 % and less than or equal to 10 % or adaptive equipment with a maximum RF output power of 10 dBm e.i.r.p.
<input type="checkbox"/>	Receiver category 3	Non-adaptive equipment with a maximum Medium Utilization (MU) factor of 1 % or adaptive equipment with a maximum RF output power of 0 dBm e.i.r.p.

2.4 Description of Test Modes and Test Frequency

The EUT has been tested under typical operating condition. The Applicant provides communication tools software to control the EUT for staying in continuous transmitting and receiving mode for testing.

Operation Frequency List :

Channel	Frequency (MHz)
00	2402
01	2403
⋮	⋮
38	2440
39	2441
40	2442
⋮	⋮
77	2479
78	2480

Note: The line display in grey were the channel selected for testing

2.5 Measurement Instruments List

RF output power & PSD & OOB & OBW & Hopping & Duty Cycle, Tx-sequence, Tx-gap & Adaptively, Blocking						
Item	Test Equipment	Manufacturer	Model No.	Serial No.	Calibration Date	Calibration Due Date
1	Spectrum Analyzer	Agilent	N9020A	US46220290	2020/06/14	2021/06/13
2	Spectrum Analyzer	Keysight	N9020A	MY53420874	2020/06/14	2021/06/13
3	Signal Generator	Agilent	N5182A	MY50142850	2020/06/14	2021/06/13
4	Signal Generator	Agilent	N5182A	MY52420355	2020/06/15	2021/06/14
5	Signal Generator	Agilent	N5181A	MY49060125	2020/06/15	2021/06/14
6	Power Sensor	Agilent	U2021XA	MY55130004	2020/06/14	2021/06/13
7	Power Sensor	Agilent	U2021XA	MY55130006	2020/06/14	2021/06/13
8	Power Sensor	Agilent	U2021XA	MY54510008	2020/06/14	2021/06/13
9	Power Sensor	Agilent	U2021XA	MY55060003	2020/06/14	2021/06/13
10	WIDEBAND RADIO COMMUNICATION TESTER	RS	CMW500	1201.0002K50-107930-CD	2020/06/14	2021/06/13
11	Temperature/Humidity Meter	Kejian	MC501	/	2020/06/16	2021/06/15
Test Software						
Name of Software				Version		
TST-PASS				1.0.5		

Transmitter spurious emissions & Receiver spurious emissions						
Item	Test Equipment	Manufacturer	Model No.	Serial No.	Calibration Date	Calibration Due Date
1	Double cone logarithmic antenna	Schwarzbeck	VULB 9168	824	2021/04/07	2022/04/06
2	Horn Antenna	Sunol Sciences Corp.	DRH-118	A062013	2020/06/18	2021/06/17
4	Controller	EM Electronics	Controller EM 1000	N/A	2020/06/18	2021/06/17
5	Amplifier	Agilent	8449B	3008A02306	2020/06/14	2021/06/13
6	Amplifier	Agilent	8447D	2944A10176	2020/06/14	2021/06/13
7	Amplifier	Brief&Smart	LNA-4018	2104197	2020/06/14	2021/06/13
8	Spectrum Analyzer	RS	FSP	1164.4391.38	2020/06/15	2021/06/14
Test software						
Name of Software				Version		
e3				6.111221a		

The calibration interval is 1 year.

3 TEST ITEM AND RESULTS

3.1 RF Output Power

Limit

ETSI EN 300 328 (V2.2.2) Sub-clause 4.3.1.2.3

TEST CONDITION	LIMIT
Normal and Extreme	20dBm(e.i.r.p)

Test Procedure

- Step 1: Use a fast power sensor suitable for 2,4 GHz and capable of minimum 1 MS/s. Use the following settings:
 - Sample speed 1 MS/s or faster.
 - The samples shall represent the RMS power of the signal.
 - Measurement duration: For non-adaptive equipment: equal to the observation period. For adaptive equipment, the measurement duration shall be long enough to ensure a minimum number of bursts (at least 10) are captured.

NOTE 1: For adaptive equipment, to increase the measurement accuracy, a higher number of bursts may be used.

- Step 2: For conducted measurements on devices with one transmit chain:
 - Connect the power sensor to the transmit port, sample the transmit signal and store the raw data. Use these stored samples in all following steps.

For conducted measurements on devices with multiple transmit chains:

- Connect one power sensor to each transmit port for a synchronous measurement on all transmits ports.
- Trigger the power sensors so that they start sampling at the same time. Make sure the time difference between the samples of all sensors is less than 500 ns.
- For each individual sampling point (time domain), sum the coincident power samples of all ports and store them. Use these summed samples in all following steps.
- Step 3: Find the start and stop times of each burst in the stored measurement samples. The start and stop times are defined as the points where the power is at least 30 dB below the highest value of the stored samples in step 2.

NOTE 2: In case of insufficient dynamic range, the value of 30 dB may need to be reduced appropriately.

- Step 4: Between the start and stop times of each individual burst calculate the RMS power over the burst using the formula below. Save these P_{burst} values, as well as the start and stop times for each burst.

$$P_{burst} = \frac{1}{K} \sum_{n=1}^k P_{sample}(n)$$

With 'k' being the total number of samples and 'n' the actual sample number

- Step 5: The highest of all P_{burst} values (value "A" in dBm) will be used for maximum e.i.r.p. calculations.
- Step 6: Add the (stated) antenna assembly gain "G" in dBi of the individual antenna. If applicable, add the additional beamforming gain "Y" in dB using the formula below:

$$P = A + G + Y$$

Test Results

Raw data reference to Section 1 from Appendix.

3.2 Duty Cycle, Tx-sequence, Tx-gap

Limit

ETSI EN 300 328 (V2.2.2) Sub-clause 4.3.1.3.3

1. For non-adaptive FHSS equipment, the Duty Cycle shall be equal to or less than the maximum value declared by the supplier. In addition, the maximum Tx -sequence time shall be 5 ms while the minimum Tx-gap time shall be 5 ms.
2. For equipment using wide band modulations other than FHSS, the Duty Cycle shall be equal to or less than the maximum value declared by the supplier.
The Tx-sequence time shall be equal to or less than 10 ms. The minimum Tx-gap time following a Tx-sequence shall be equal to the duration of that proceeding Tx-sequence with a minimum of 3,5 ms.

Test Procedure

The test procedure, which shall only be performed for non-adaptive systems, shall be as follows:

- **Step 1:** Use the same stored measurement samples from the procedure described in RF output power measurement
- **Step 2:** Between the saved start and stop times of each individual burst, calculate the TxOn time. Save these TxOn values.
- **Step 3:** All TxOn times between the end of the first gap (which is the start of the first burst within the observation period) and the start of the last burst (within this observation period) divided by the observation period.
- **Step 4:**
Identify any TxOff time that is equal to or greater than the minimum Tx-gap time. These are the potential valid gap times to be further considered in this procedure.

Starting from the second identified gap, calculate the time from the start of this gap to the end of the preceding gap. This time is the Tx-sequence time for this transmission. Repeat this procedure until the last identified gap within the observation period is reached.

Test Results

Not applicable to this device which was adaptive equipment and cannot operate in a non-adaptive mode.

3.3 Accumulated Transmit Time, Frequency Occupation and Hopping Sequence

LIMIT

ETSI EN 300 328 (V2.2.2) Sub-clause 4.3.1.4.3.

Limit of Accumulated Transmit Time

TEST CONDITION	LIMIT
Non-adaptive frequency hopping systems	≥ 15 ms within $5\text{ms} \times \text{hopping frequencies (N)}$
Adaptive frequency hopping systems	$\geq 0.4\text{s}$ within $0.4\text{s} \times \text{hopping frequencies (N)}$

Note: N means minimum number of hopping frequencies (N) that have to be used.

Limit of Minimum Frequency Occupation

TEST CONDITION	LIMIT
Non-adaptive frequency hopping systems Adaptive frequency hopping systems	<p>Option 1: Each hopping frequency of the hopping sequence shall be occupied at least once within a period not exceeding four times the product of the dwell time and the number of hopping frequencies in use.</p> <p>Option 2: The occupation probability for each frequency shall be between $((1 / U) \times 25 \%)$ and 77 % where U is the number of hopping frequencies in use.</p>

Hopping Sequence

TEST CONDITION	LIMIT
Non-adaptive frequency hopping systems Adaptive frequency hopping systems	<p>The hopping sequence(s) shall contain at least N hopping frequencies at all times, where N is 15 or 15 divided by the minimum Hopping Frequency Separation in MHz, whichever is the greater.</p> <p>Adaptive Frequency Hopping equipment shall be capable of operating over a minimum of 70 % of the authorized band.</p>

Remark: This test item is not applicable to DSSS/OFDM system device.

Test Procedure

- The measurement shall be performed on a minimum of 2 hopping frequencies chosen arbitrary from the actual hopping sequence. The results as well as the frequencies on which the test was performed shall be recorded in the test report.
- The analyzer shall be set as follows:

Centre Frequency:	Equal to the hopping frequency being investigated
Frequency Span:	0 Hz
RBW:	~ 50 % of the Occupied Channel Bandwidth
VBW:	\geq RBW
Detector Mode:	RMS
Sweep time:	400 ms \times Minimum number of hopping frequencies (N)
Number of sweep points:	30 000
Trace mode:	Clear / Write
Trigger:	Free Run

3. Identify the data points related to the frequency being investigated by applying a threshold.
4. Count the number of data points identified as resulting from transmissions on the frequency being investigated and multiply this number by the time difference between two consecutive data points.
5. Record this value as Accumulated Transmit Time in test report.
6. Set Sweep time to $4 \times \text{Dwell Time} \times \text{Actual numbers of hopping frequencies in use}$ and repeat 3 and 4 to get Frequency Occupation Time and Number.
7. Make the following changes on the analyzer for Hopping Sequence measurement

Centre Frequency:	Equal to the hopping frequency being investigated
Start Frequency:	2 400 MHz
Stop Frequency:	2 483,5 MHz
RBW:	~ 50 % of the Occupied Channel Bandwidth (single hop)
VBW:	\geq RBW
Detector Mode:	RMS
Sweep time:	1 s
Number of sweep points:	30 000
Trace mode:	Max Hold
Trigger:	Free Run

8. When the trace has completed, identify the number of hopping frequencies used by the hopping sequence.
9. For adaptive systems, using the lowest and highest -20 dB points from the total spectrum envelope obtained in step 7, it shall be verified whether the system uses 70 % of the authorized band. The result shall be recorded in the test report.

Test Results

Raw data reference to Section 2 from Appendix.

3.4 Hopping Frequency Separation

Limit

ETSI EN 300 328 (V2.2.2) Sub-clause 4.3.1.5.3

1. For non-adaptive Frequency Hopping equipment, the Hopping Frequency Separation shall be equal or greater than the Occupied Channel Bandwidth, with a minimum separation of 100 kHz. For equipment with a maximum declared RF Output power level of less than 10 dBm e.i.r.p. or for non-adaptive Frequency Hopping equipment operating in a mode where the RF Output power is less than 10 dBm e.i.r.p. only the minimum Hopping Frequency Separation of 100 kHz applies.
2. For adaptive Frequency Hopping equipment, the minimum Hopping Frequency Separation shall be 100 kHz.

Test Procedure

- **Step 1:** The output of the transmitter shall be connected to a spectrum analyser
- **Step 2:** The analyser shall be set as follows:

Centre Frequency:	Centre of the two adjacent hopping frequencies
Span:	Sufficient to see the complete power envelope of both hopping frequencies
Stop Frequency:	2 483,5 MHz
RBW:	1 % of the span
VBW:	3 × RBW
Detector Mode:	RMS
Sweep time:	1 s
Trace mode:	Max Hold

- **Step 3:** Wait for the trace to stabilize. Use the marker-delta function to determine the Hopping Frequency Separation between the centres of the two adjacent hopping frequencies (e.g. by identifying peaks or notches at the centre of the power envelope for the two adjacent signals).

Test Results

Raw data reference to Section 3 from Appendix.

3.5 Medium Utilisation (MU) factor

Limit

ETSI EN 300 328 (V2.2.2) Sub-clause 4.3.1.6.3

The maximum Medium Utilisation factor for non-adaptive equipment shall be 10 %.

Definition

The Medium Utilisation (MU) factor is a measure to quantify the amount of resources (Power and Time) used by non-adaptive equipment. The Medium Utilisation factor is defined by the formula:

$$\text{MU} = (P/100 \text{ mW}) \times \text{DC}$$

Where: MU is Medium Utilisation factor in %.

P is the RF output power expressed in mW.

DC is the Duty Cycle expressed in %.

NOTE: The equipment may have dynamic behaviour with regard to duty cycle and corresponding power level.

Test Results

Not applicable to this device which cannot operation in a non-adaptive mode.

3.6 Occupied Channel Bandwidth

Limit

ETSI EN 300 328 (V2.2.2) Sub-clause 4.3.1.8.3

The Occupied Channel Bandwidth for each hopping frequency shall fall completely within the band 2.4GHz-2.4835GHz.

Test Procedure

1. The measurement shall be performed only on the lowest and the highest frequency within stated frequency range
2. The test procedure shall be follows:

Step1: Connect the UUT to the spectrum analyzer and use the following settings

Centre Frequency:	The centre frequency of the channel under test
Resolution BW:	~ 1% of the span without going below 1 %
Video BW:	3 × RBW
Frequency Span:	2 × Occupied Channel Bandwidth (e.g. 40 MHz for a 20 MHz channel)
Detector Mode:	RMS
Trace Mode:	MaxHold
Sweep time:	1s

Step 2: Wait until the trace is completed. Find the peak value of the trace and place the analyzer marker on this peak.

Step 3: Use the 99 % bandwidth function of the spectrum analyzer to measure the Occupied Channel Bandwidth of the EUT.

Test Result

Raw data reference to Section 4 from Appendix.

3.7 Transmitter unwanted emissions in the out-of-band domain

Limit

ETSI EN 300 328 (V2.2.2) Sub-clause 4.3.1.9.3

The transmitter unwanted emissions in the out-of-band domain but outside the allocated band, shall not exceed the values provided by the mask in figure 1.

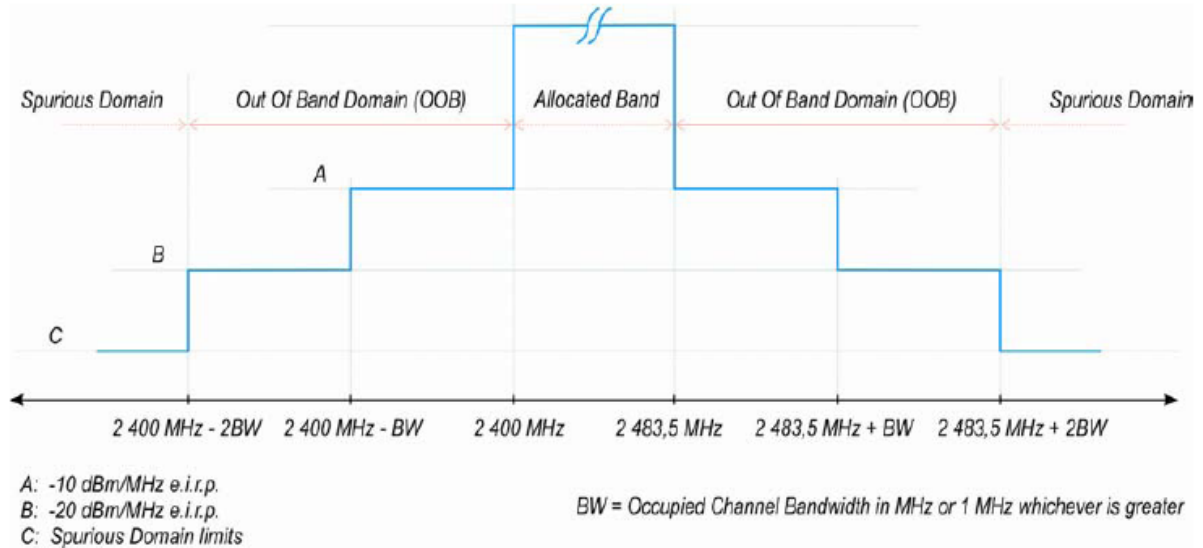

Figure 1: Transmit mask

Test Procedure

1. The measurements shall be performed at both normal environmental conditions and at the extremes of the operating temperature range.
2. For conducted measurements on devices with multiple transmit chains using the results for each of the transmit chains for the corresponding 1MHz segments shall be added and compared with the transmit mask limit.
3. The analyzer shall be set as follows:

Centre Frequency:	Center of each segments
Frequency Span:	0 Hz
RBW:	1M
VBW:	3M
Filter mode:	Channel filter
Trace Mode:	Clear / Write
Detector Mode:	RMS
Number of sweep points:	5 000
Sweep mode:	Continuous
Trigger:	Video trigger
Sweep Time:	> 120 % of the duration of the longest burst detected

4. Save the value measured of each segments.

Test Result

Raw data reference to Section 5 from Appendix.

3.8 Transmitter unwanted emissions in the spurious domain

Limit

ETSI EN 300 328 (V2.2.2) Sub-clause 4.3.1.10.3

The transmitter unwanted emissions in the spurious domain shall not exceed the values given in table 4. In case of equipment with antenna connectors, these limits apply to emissions at the antenna port (conducted). For emissions radiated by the cabinet or emissions radiated by integral antenna equipment (without antenna connectors), these limits are e.r.p. for emissions up to 1 GHz and e.i.r.p. for emissions above 1 GHz.

Table 4: Transmitter limits for spurious emissions

Frequency range	Maximum power	Bandwidth
30 MHz to 47 MHz	-36 dBm	100 kHz
47 MHz to 74 MHz	-54 dBm	100 kHz
74 MHz to 87,5 MHz	-36 dBm	100 kHz
87,5 MHz to 118 MHz	-54 dBm	100 kHz
118 MHz to 174 MHz	-36 dBm	100 kHz
174 MHz to 230 MHz	-54 dBm	100 kHz
230 MHz to 470 MHz	-36 dBm	100 kHz
470 MHz to 694 MHz	-54 dBm	100 kHz
694 MHz to 1 GHz	-36 dBm	100 kHz
1 GHz to 12,75 GHz	-30 dBm	1 MHz

Test Procedure

1. The measurement performed at the lowest and the highest channel on which the equipment can operate.
2. The EUT was placed on a turntable with 1.5m height.
3. The test distance between the receiving antenna and the EUT is 3 meter, while the receiving (test) antenna is kept at 1.5 meter height.
4. Set EUT in continuous transmitting with maximum output power.
5. The table was rotated from 0 to 360 degree to search the highest radiated emission.
6. Repeat step 3 to 5 for each polarization and channel to find the worst emission level.
7. The results obtained are compared to the limits in order to prove compliance with the requirement.

Test Configuration

Effective Radiated Power measurement (30 MHz to 12.75 GHz)

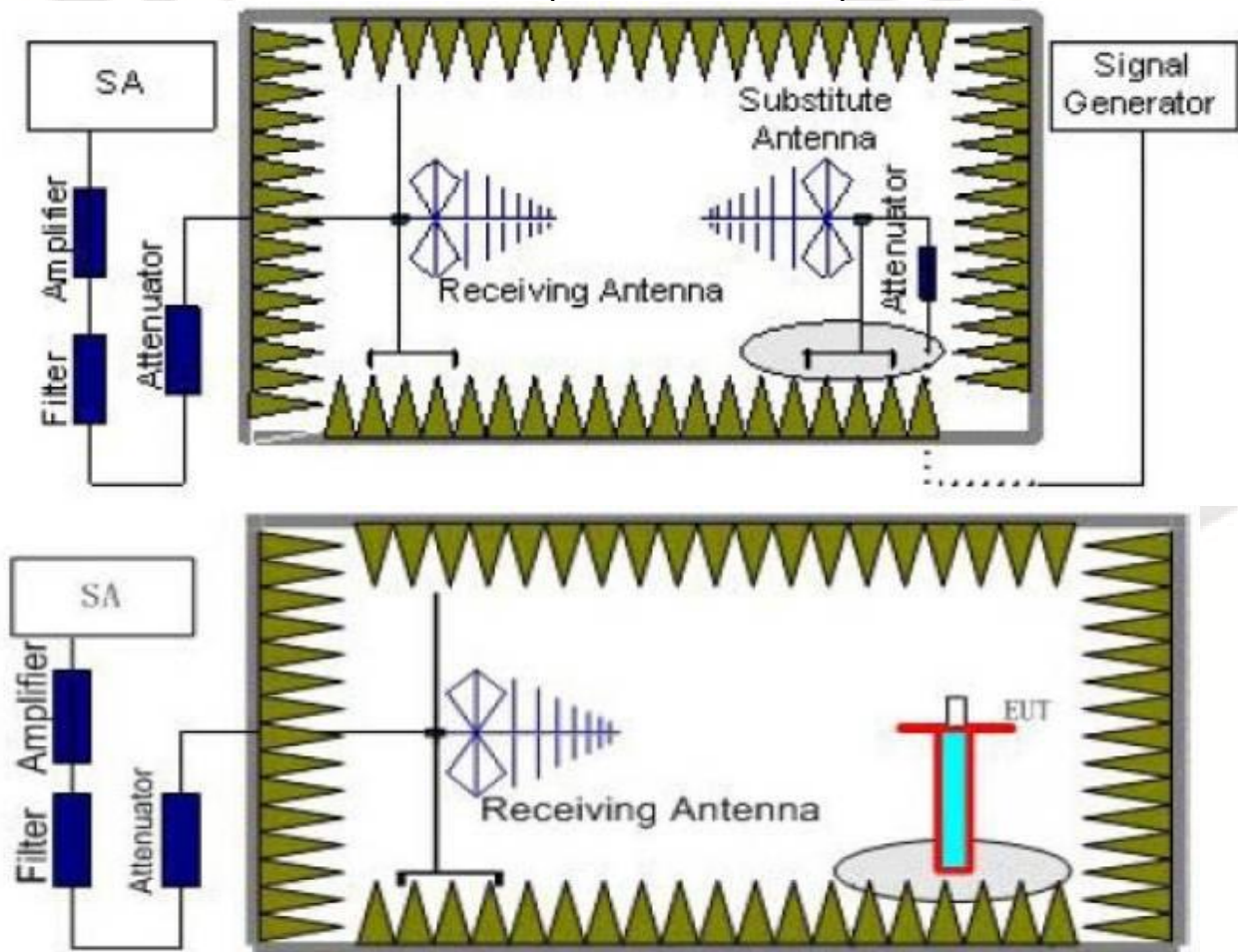

Test Results

Remark: We test all modulation type, and recorded the worst case at GFSK DH5 mode.

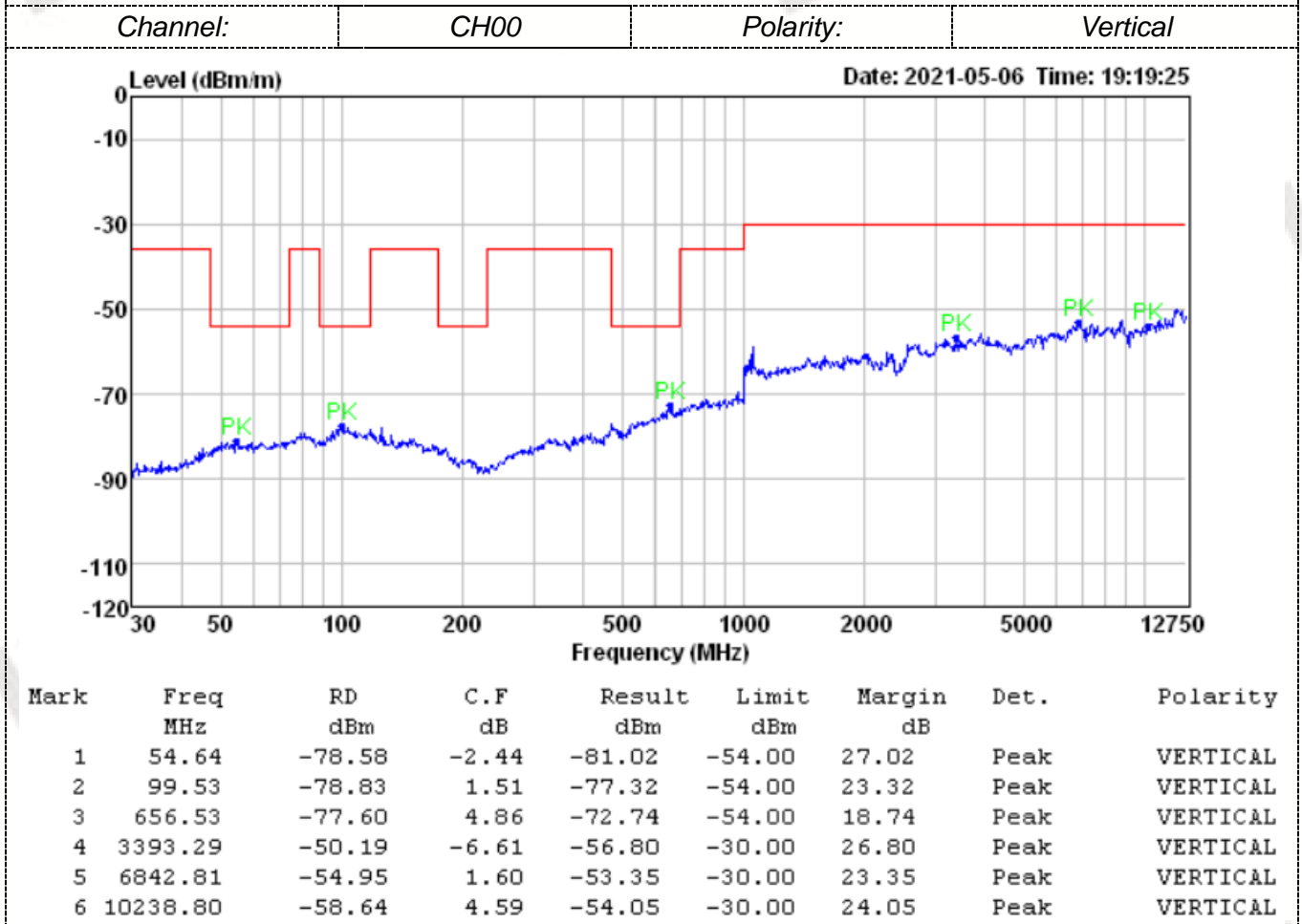
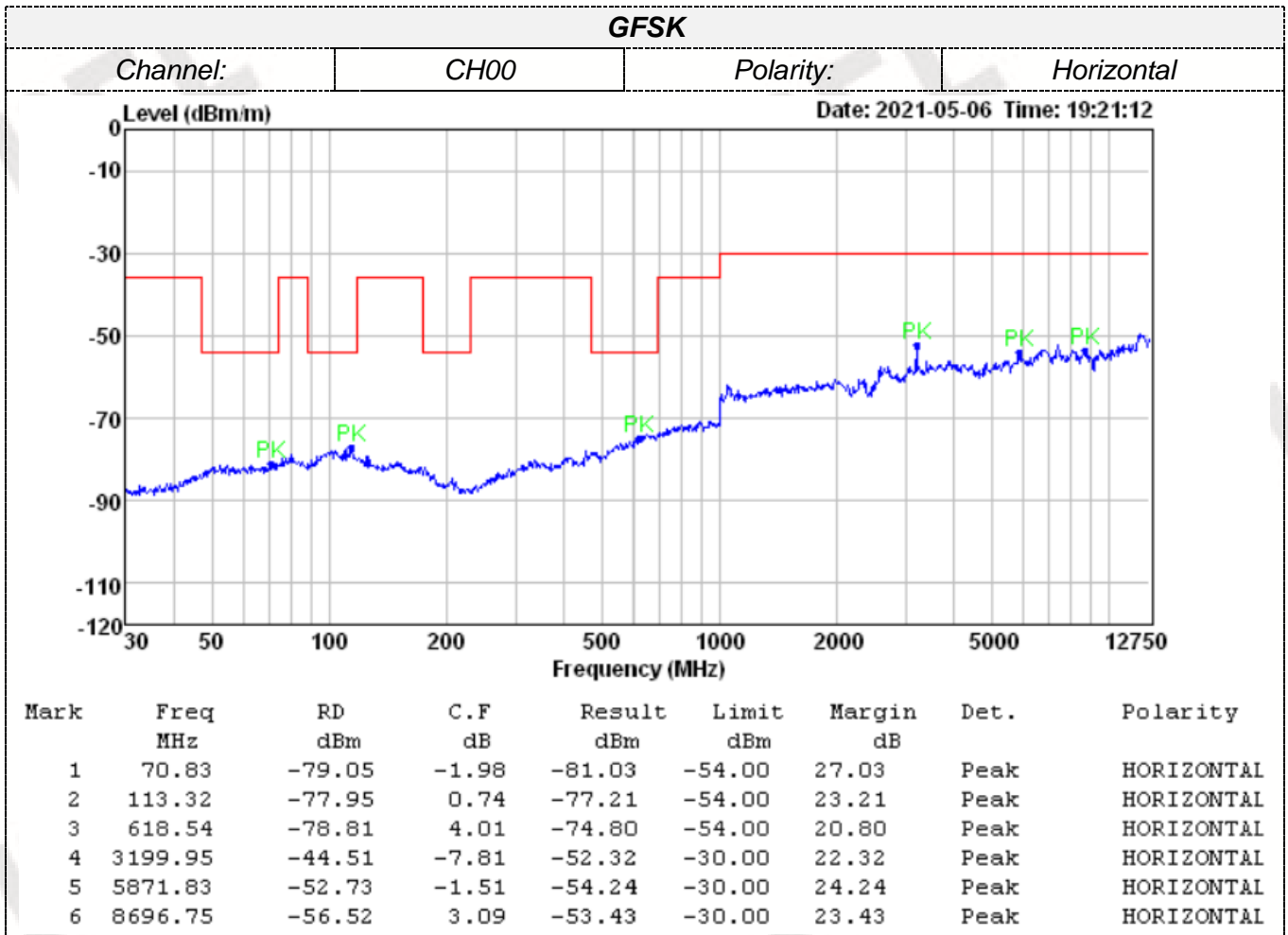

GFSK

Channel: CH78 Polarity: Horizontal

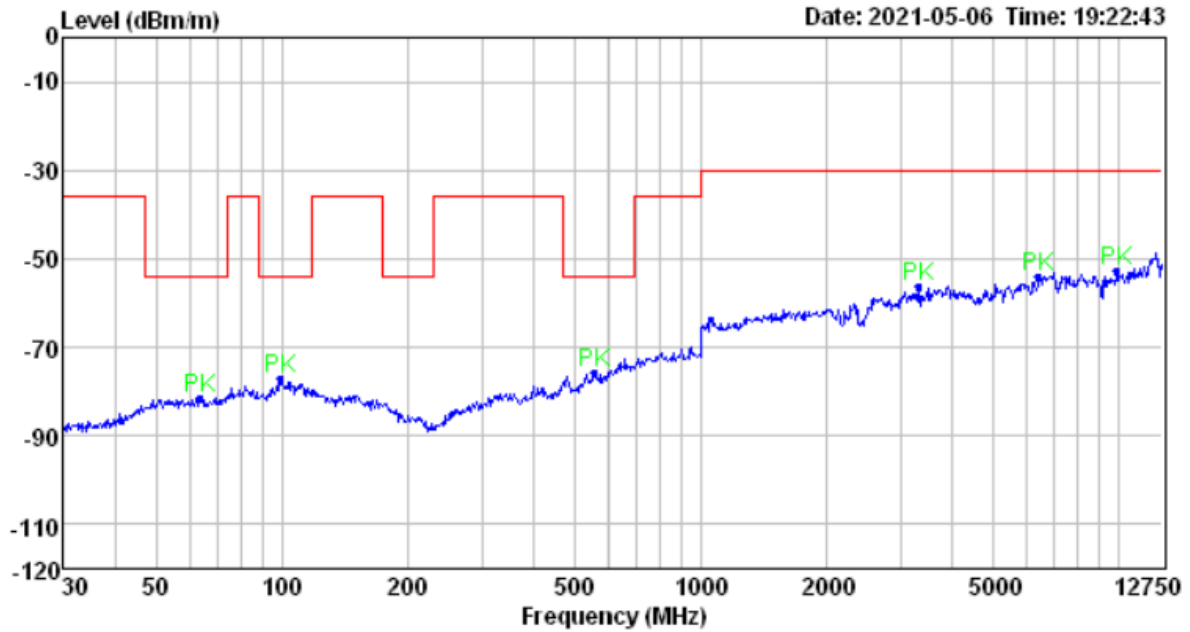

Mark	Freq MHz	RD dBm	C.F dB	Result dBm	Limit dBm	Margin dB	Det.	Polarity
1	63.54	-79.09	-2.39	-81.48	-54.00	27.48	Peak	HORIZONTAL
2	98.49	-78.27	1.17	-77.10	-54.00	23.10	Peak	HORIZONTAL
3	556.77	-77.91	2.30	-75.61	-54.00	21.61	Peak	HORIZONTAL
4	3307.83	-49.01	-7.15	-56.16	-30.00	26.16	Peak	HORIZONTAL
5	6452.94	-53.69	-0.41	-54.10	-30.00	24.10	Peak	HORIZONTAL
6	9904.88	-58.03	5.41	-52.62	-30.00	22.62	Peak	HORIZONTAL

Channel: CH78 Polarity: Vertical

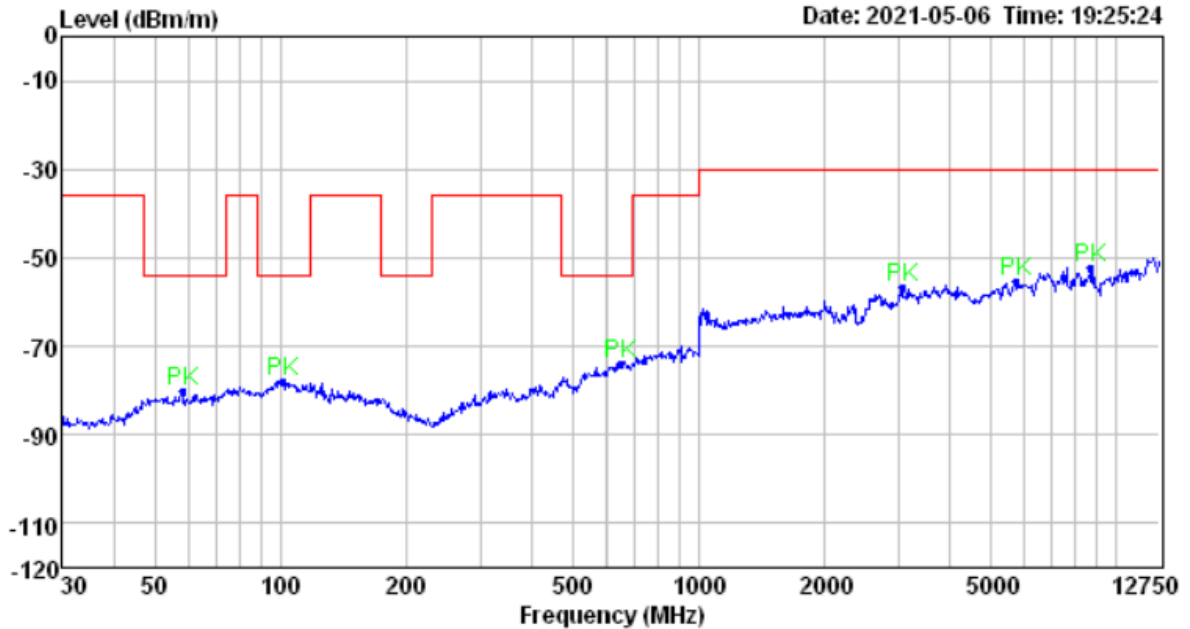

Mark	Freq MHz	RD dBm	C.F dB	Result dBm	Limit dBm	Margin dB	Det.	Polarity
1	58.00	-77.62	-2.50	-80.12	-54.00	26.12	Peak	VERTICAL
2	100.93	-79.25	1.54	-77.71	-54.00	23.71	Peak	VERTICAL
3	647.39	-78.55	4.79	-73.76	-54.00	19.76	Peak	VERTICAL
4	3072.00	-48.47	-8.40	-56.87	-30.00	26.87	Peak	VERTICAL
5	5767.92	-53.51	-1.92	-55.43	-30.00	25.43	Peak	VERTICAL
6	8674.60	-55.20	3.03	-52.17	-30.00	22.17	Peak	VERTICAL

3.9 Receiver spurious emissions

LIMIT

ETSI EN 300 328 (V2.2.2) Sub-clause 4.3.1.11.3

The spurious emissions of the receiver shall not exceed the values given below:

Spurious emission limits for receivers

Frequency	Maximum power, e.r.p.	Measurement bandwidth
30 MHz to 1 GHz	-57 dBm	100 KHz
30 MHz to 12.75 GHz	-47 dBm	1 MHz

Test Procedure

The same as clause 3.8

Test Configuration

Effective Radiated Power measurement (30 MHz to 12.75 GHz)

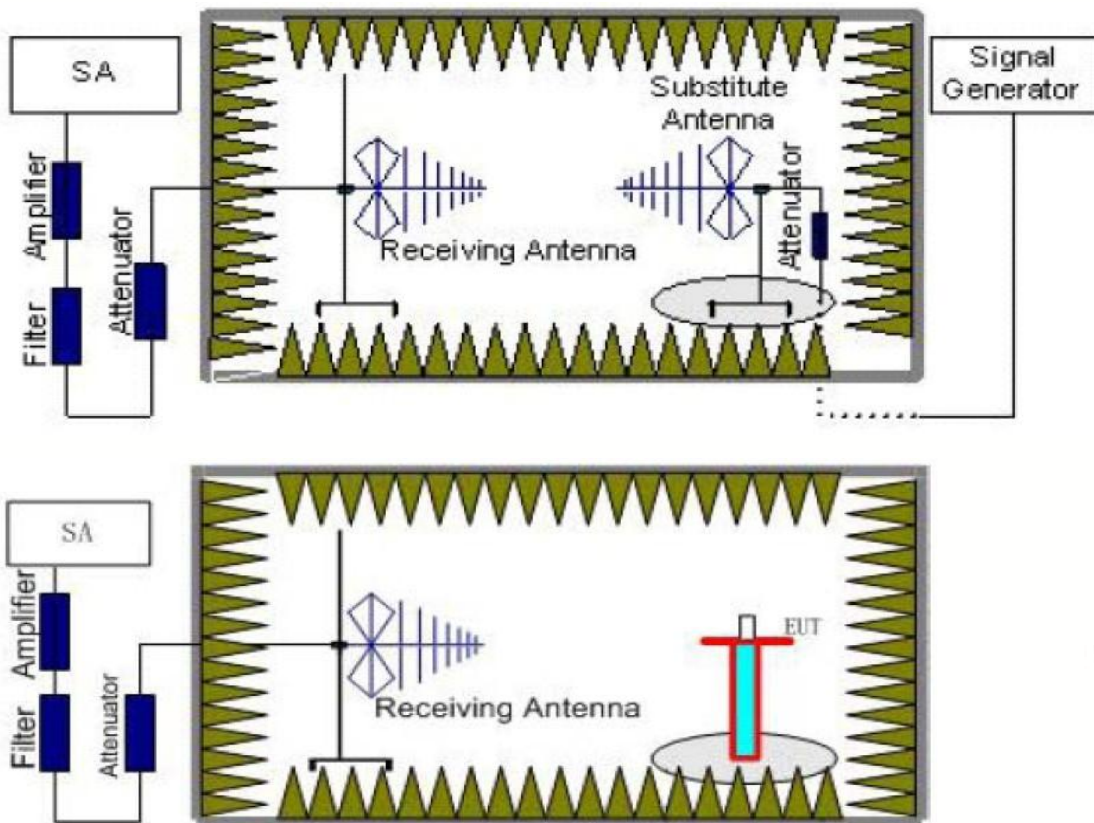

Test Results

Remark: We test all modulation type, and recorded the worst case at GFSK DH5 mode.

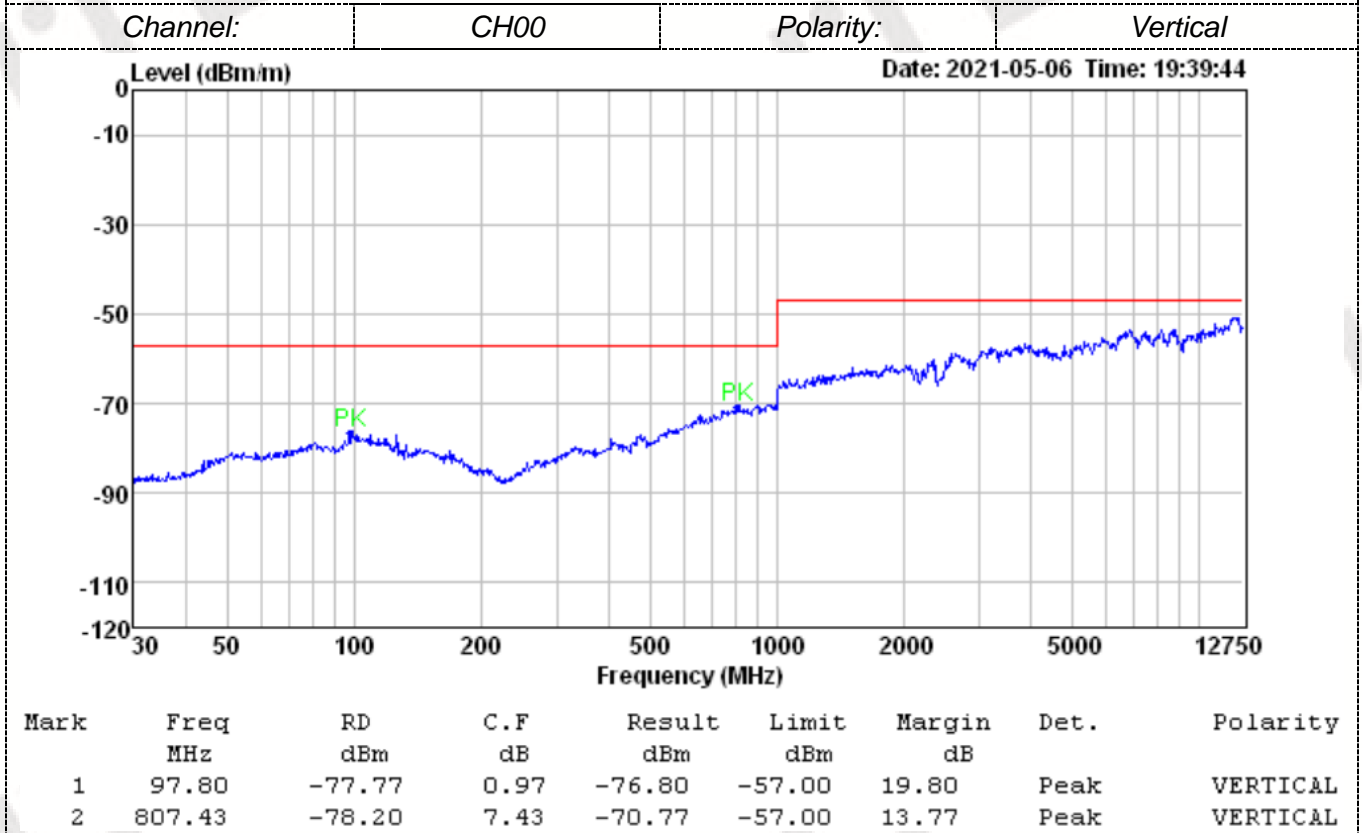
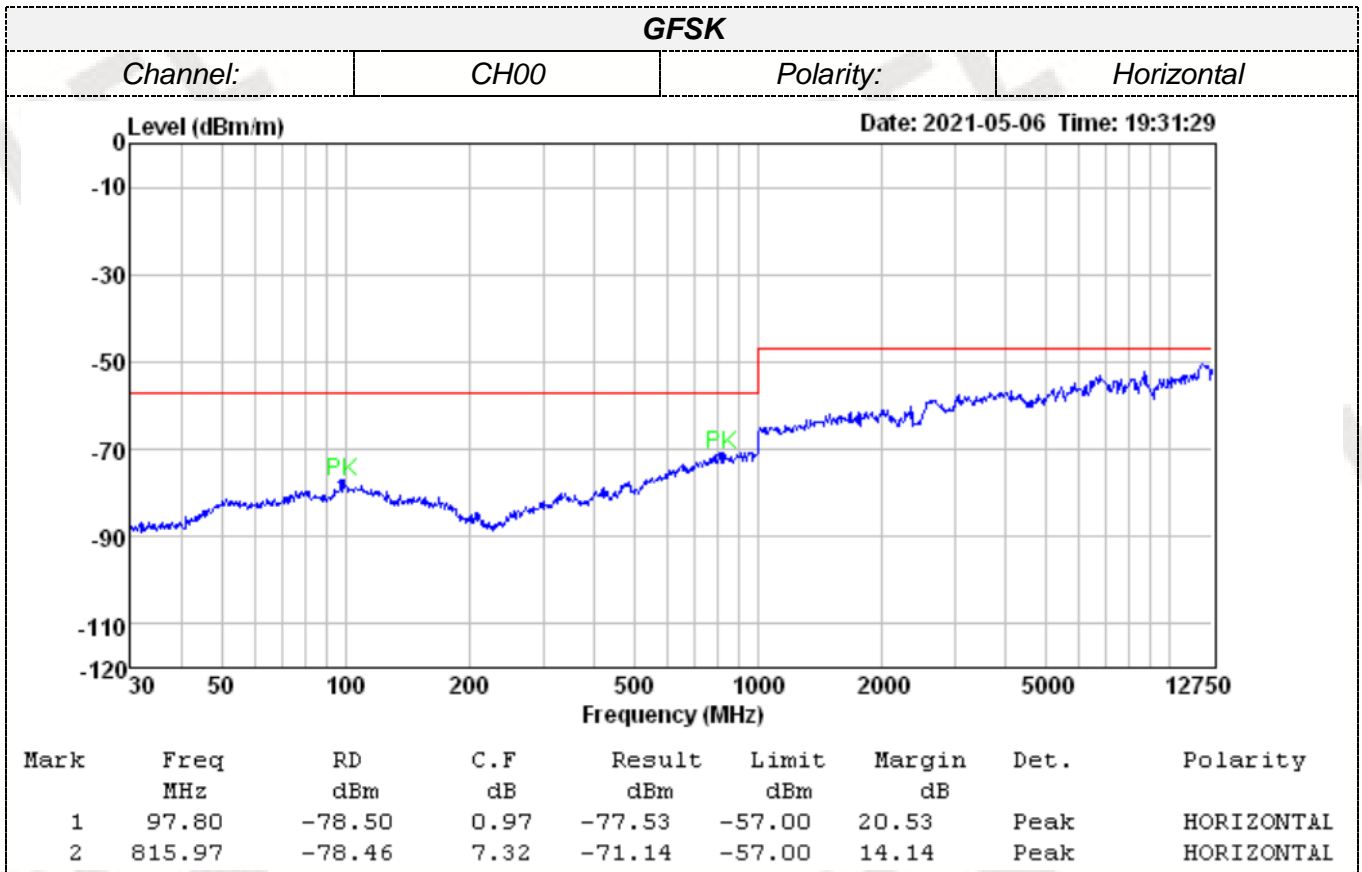

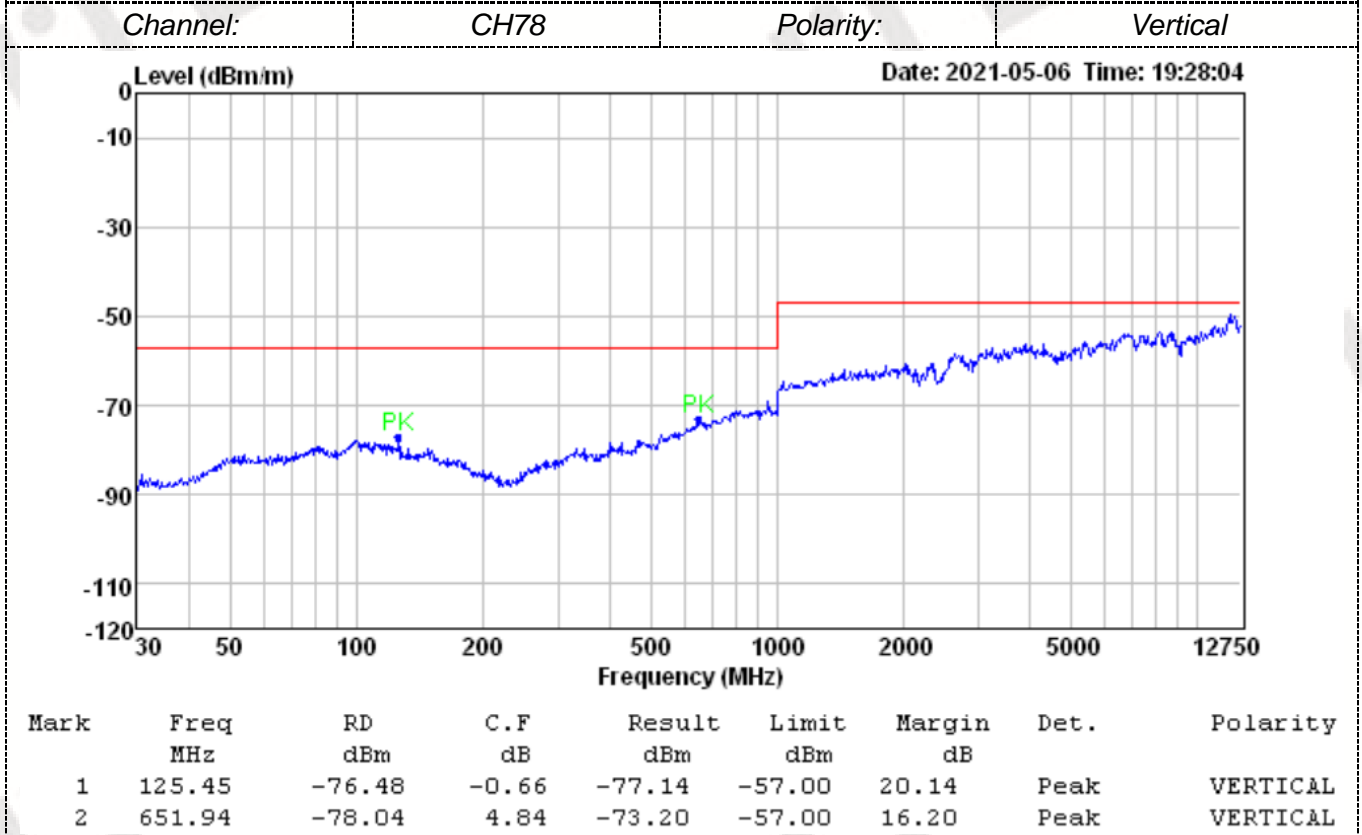
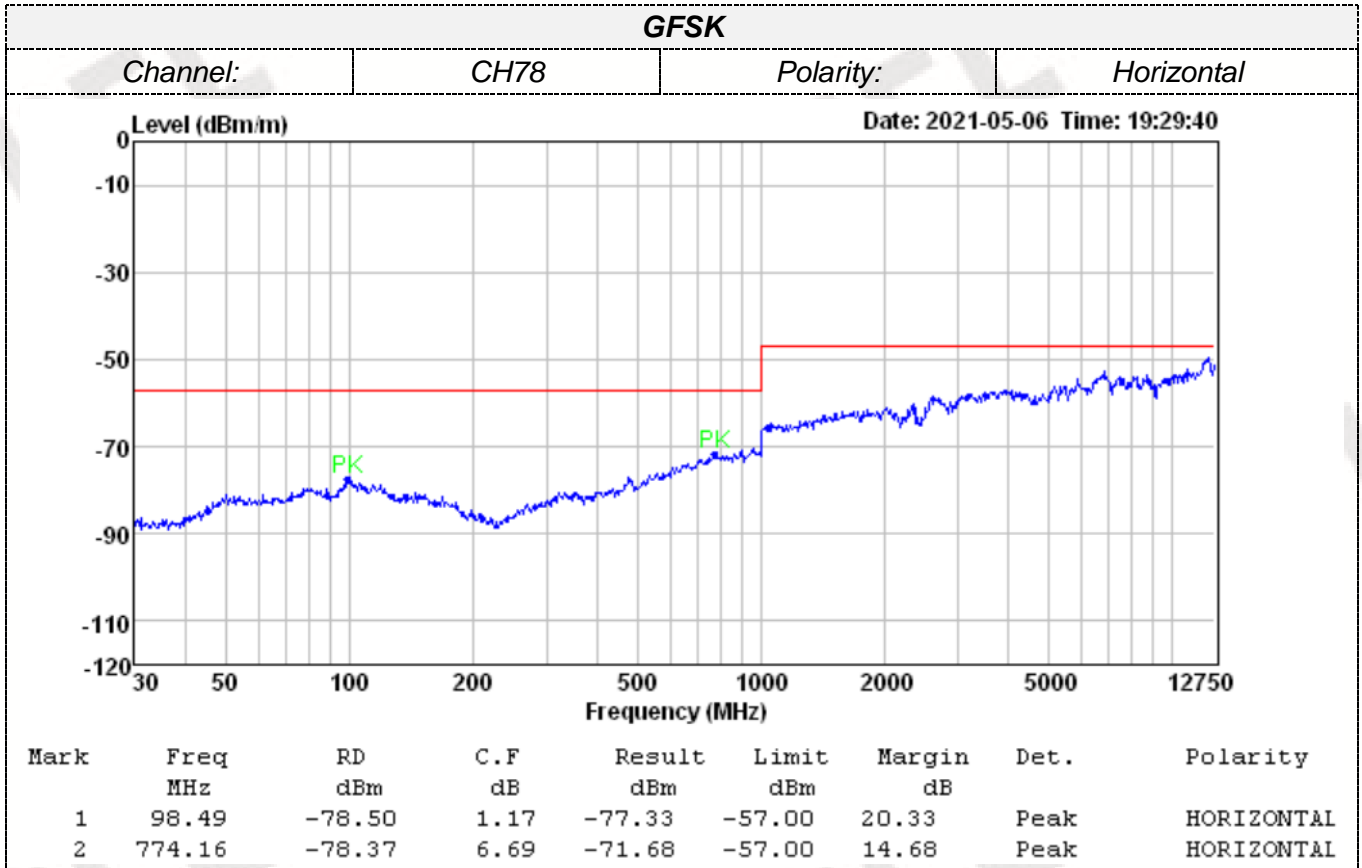

3.10 Adaptivity

Limits

For Requirements and Limits please refer to ETSI EN 300 328 V2.2.2 Sub - clause 4.3.1.7.2.1 & 4.3.1.7.3.2

Test Procedure

1. The measurement procedure follows the clause 5.4.6.2.1 of the ETSI EN 300 328 V2.2.2 (2019-07).
2. For conducted measurements on device with multiple transmit chains and receive chains. The power splitter/combiner shall be used to combine all the transmit/receive chains (antenna outputs) into a single test point. The insertion loss of the power splitter/combiner shall be taken into account.
3. Interference signal shall be a 100 % duty cycle interference signal is injected on the current operating channel of the UUT. This interference signal shall meet the requirements as follow:
The 99 % bandwidth (the bandwidth containing 99 % of the power) of this inference signal shall be within a range from 120 % to 200 % of the Occupied Channel Bandwidth of the UUT with a minimum of 5 MHz, while the difference between the lowest and highest level within the Occupied Channel Bandwidth of the UUT shall be maximum 4 dB.
4. Blocking signal shall be a 100 % duty cycle CW signal, and The frequency and level shall be set as follow:

Equipment Type (LBT / non- LBT)	Wanted signal mean power from companion device	Blocking signal frequency [MHz]	Blocking signal power [dBm]	Type of interfering signal
LBT	sufficient to maintain the link (see note 2)	2 395 or 2 488,5 (see note 1)	-35	CW
Non-LBT	-30 dB			
NOTE 1: The highest frequency shall be used for testing operating channels within the range 2 400 MHz to 2 442 MHz, while the lowest frequency shall be used for testing operating channels within the range 2 442 MHz to 2 483,5 MHz.				
NOTE 2: A typical value which can be used in most cases is -50 dBm/MHz.				

5. The test not applicable to none-adaptive equipment and adaptive equipment which maximum RF Output power level is less than 10 dBm e.i.r.p.

Test Configuration

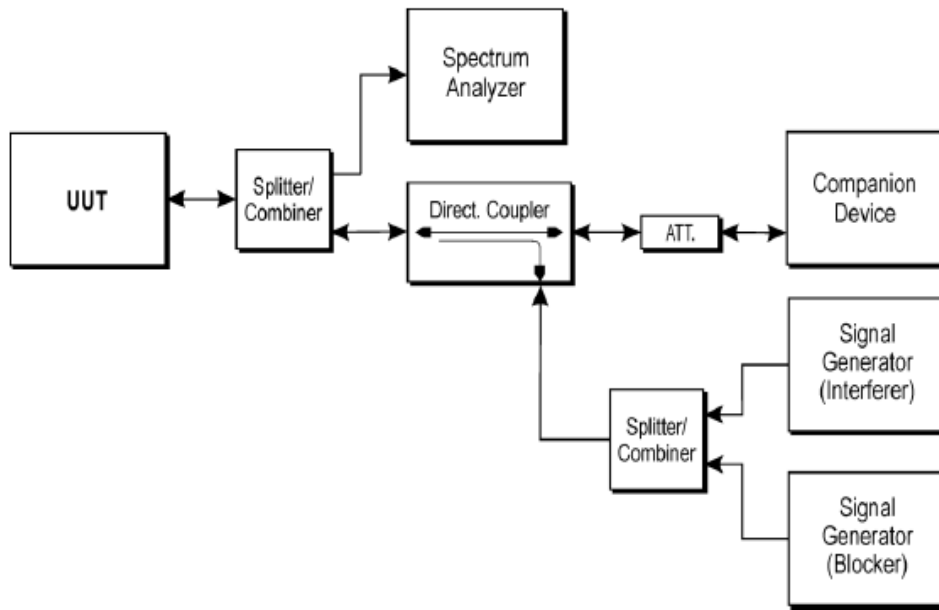

Test Results

Not applicable to this device which maximum RF Output power level is less than 10 dBm e.i.r.p.

3.11 Receiver Blocking

Limits

While maintaining the minimum performance criteria as defined in clause 4.3.1.12.3, the blocking levels at specified frequency offsets shall be equal to or greater than the limits defined for the applicable receiver category provided in table 6, table 7 or table 8.

Table 6: Receiver Blocking parameters for Receiver Category 1 equipment

Wanted signal mean power from companion device (dBm) (see notes 1 and 4)	Blocking signal frequency (MHz)	Blocking signal power (dBm) (see note 4)	Type of blocking signal
$(-133 \text{ dBm} + 10 \times \log_{10}(\text{OCBW}))$ or -68 dBm whichever is less (see note 2)	2 380 2 504	-34	CW
$(-139 \text{ dBm} + 10 \times \log_{10}(\text{OCBW}))$ or -74 dBm whichever is less (see note 3)	2 300 2 330 2 360 2 524 2 584 2 674		
NOTE 1: OCBW is in Hz.			
NOTE 2: In case of radiated measurements using a companion device and the level of the wanted signal from the companion device cannot be determined, a relative test may be performed using a wanted signal up to $P_{\text{min}} + 26 \text{ dB}$ where P_{min} is the minimum level of wanted signal required to meet the minimum performance criteria as defined in clause 4.3.1.12.3 in the absence of any blocking signal.			
NOTE 3: In case of radiated measurements using a companion device and the level of the wanted signal from the companion device cannot be determined, a relative test may be performed using a wanted signal up to $P_{\text{min}} + 20 \text{ dB}$ where P_{min} is the minimum level of wanted signal required to meet the minimum performance criteria as defined in clause 4.3.1.12.3 in the absence of any blocking signal.			
NOTE 4: The level specified is the level at the UUT receiver input assuming a 0 dBi antenna assembly gain. In case of conducted measurements, this level has to be corrected for the (in-band) antenna assembly gain (G). In case of radiated measurements, this level is equivalent to a power flux density (PFD) in front of the UUT antenna with the UUT being configured/positioned as recorded in clause 5.4.3.2.2.			

Table 7: Receiver Blocking parameters receiver Category 2 equipment

Wanted signal mean power from companion device (dBm) (see notes 1 and 3)	Blocking signal frequency (MHz)	Blocking signal power (dBm) (see note 3)	Type of blocking signal
$(-139 \text{ dBm} + 10 \times \log_{10}(\text{OCBW}) + 10 \text{ dB})$ or $(-74 \text{ dBm} + 10 \text{ dB})$ whichever is less (see note 2)	2 380 2 504 2 300 2 584	-34	CW
NOTE 1: OCBW is in Hz.			
NOTE 2: In case of radiated measurements using a companion device and the level of the wanted signal from the companion device cannot be determined, a relative test may be performed using a wanted signal up to $P_{\text{min}} + 26 \text{ dB}$ where P_{min} is the minimum level of wanted signal required to meet the minimum performance criteria as defined in clause 4.3.1.12.3 in the absence of any blocking signal.			
NOTE 3: The level specified is the level at the UUT receiver input assuming a 0 dBi antenna assembly gain. In case of conducted measurements, this level has to be corrected for the (in-band) antenna assembly gain (G). In case of radiated measurements, this level is equivalent to a power flux density (PFD) in front of the UUT antenna with the UUT being configured/positioned as recorded in clause 5.4.3.2.2.			

Table 8: Receiver Blocking parameters receiver Category 3 equipment

Wanted signal mean power from companion device (dBm) (see notes 1 and 3)	Blocking signal frequency (MHz)	Blocking signal power (dBm) (see note 3)	Type of blocking signal
$(-139 \text{ dBm} + 10 \times \log_{10}(\text{OCBW}) + 20 \text{ dB})$ or $(-74 \text{ dBm} + 20 \text{ dB})$ whichever is less (see note 2)	2 380 2 504 2 300 2 584	-34	CW
NOTE 1: OCBW is in Hz.			
NOTE 2: In case of radiated measurements using a companion device and the level of the wanted signal from the companion device cannot be determined, a relative test may be performed using a wanted signal up to $P_{\min} + 30 \text{ dB}$ where P_{\min} is the minimum level of wanted signal required to meet the minimum performance criteria as defined in clause 4.3.1.12.3 in the absence of any blocking signal.			
NOTE 3: The level specified is the level at the UUT receiver input assuming a 0 dBi antenna assembly gain. In case of conducted measurements, this level has to be corrected for the (in-band) antenna assembly gain (G). In case of radiated measurements, this level is equivalent to a power flux density (PFD) in front of the UUT antenna with the UUT being configured/positioned as recorded in clause 5.4.3.2.2.			

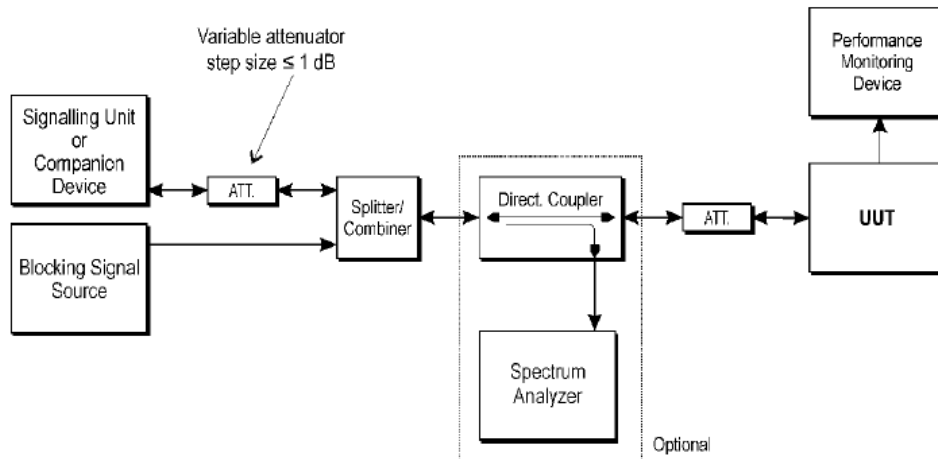
Test Configuration**Test Procedure**

The procedure in step 1 to step 6 below shall be used to verify the receiver blocking requirement as described in clause 4.3.1.12 or clause 4.3.2.11.

Step 1:

- For non-FHSS equipment, the UUT shall be set to the lowest operating channel on which the blocking test has to be performed (see clause 5.4.11.1).

Step 2:

- The blocking signal generator is set to the first frequency as defined in the appropriate table corresponding to the receiver category and type of equipment.

Step 3:

- With the blocking signal generator switched off, a communication link is established between the UUT and the associated companion device using the test setup shown in figure 6.
- Unless the option provided in note 2 of the applicable table referred to in clause 5.4.11.2.1 is used, the level of the wanted signal shall be set to the value provided in the table corresponding to the receiver category and type of equipment. The test procedure defined in clause 5.4.2, and more in particular clause 5.4.2.2.1.2, can be used to measure the (conducted) level of the wanted signal however no correction shall be made for antenna gain of the companion device (step 6 in clause 5.4.2.2.1.2 shall be ignored). This level may be measured directly at the output of the companion device and a correction is made for the coupling loss into the UUT.

- When the option provided in note 2 of the applicable table referred to in clause 5.4.11.2.1 is used, the

attenuation of the variable attenuator shall be increased in 1 dB steps to a value at which the minimum performance criteria as specified in clause 4.3.1.12.3 or clause 4.3.2.11.3 is still met. The resulting level for the wanted signal at the input of the UUT is P_{min} . This signal level (P_{min}) is increased by the value provided in note 2 of the applicable table corresponding to the receiver category and type of equipment.

Step 4:

- The blocking signal at the UUT is set to the level provided in the table corresponding to the receiver category and type of equipment. Where the manufacturer has declared the actual antenna gain for each of the applicable blocking frequencies (see clause 5.4.1 m) ii)) this blocking level shall be adjusted for the difference between the in-band antenna assembly gain (G) and the actual antenna gain for the blocking frequency being tested. See also note 5 in table 6, note 4 in table 7 and note 4 in table 8 or note 5 in table 14, note 4 in table 15 and note 4 in table 16. Where the actual antenna gains at the blocking frequencies have not been declared, then the antenna gain at the blocking frequencies shall be assumed identical to the in-band antenna gain.

- If the performance criteria as specified in clause 4.3.1.12.3 or clause 4.3.2.11.3 is met then proceed to step 6.

Step 5:

- If the performance criteria as specified in clause 4.3.1.12.3 or clause 4.3.2.11.3 is not met, step 3 and step 4 shall be repeated after that the frequency of the blocking signal set in step 2 has been increased with a value equal to the occupied channel bandwidth except:

- For the blocking frequency 2 380 MHz, where this frequency offset shall be less than or equal to 10 MHz. If this frequency offset is more than 7 MHz, the level of the wanted signal shall be increased by 3 dB.

- For the blocking frequency 2 503,5 MHz, where this frequency offset shall be less than or equal to 10 MHz. If this frequency offset is more than 7 MHz, the level of the wanted signal shall be decreased by 3 dB.

- If the performance criteria as specified in clause 4.3.1.12.3 or clause 4.3.2.11.3 is not met, step 3 and step 4 shall be repeated after that the frequency of the blocking signal set in step 2 has been decreased with a value equal to the occupied channel bandwidth except:

- For the blocking frequency 2 380 MHz, where this frequency offset shall be less than or equal to 10 MHz. If this frequency offset is more than 7 MHz, the level of the wanted signal shall be decreased by 3 dB.

- For the blocking frequency 2 503,5 MHz, where this frequency offset shall be less than or equal to 10 MHz. If this frequency offset is more than 7 MHz, the level of the wanted signal shall be increased by 3 dB.

- If the performance criteria as specified in clause 4.3.1.12.3 or clause 4.3.2.11.3 is still not met, the UUT fails to comply with the Receiver Blocking requirement and step 6 and step 7 are no longer required.

- It shall be recorded in the test report whether the shift of blocking frequencies as described in the present step was used.

Step 6:

- Repeat step 4 and step 5 for each remaining combination of frequency and level for the blocking signal as provided in the table corresponding to the receiver category and type of equipment.

Step 7:

- For non-FHSS equipment, repeat step 2 to step 6 with the UUT operating at the highest operating channel on which the blocking test has to be performed (see clause 5.4.11.1).

Step 8:

- It shall be assessed and recorded in the test report whether the UUT complies with the Receiver Blocking requirement.

Test result

Remark:

1. According to the Power measurement the device belongs to Receiver category 2.
2. With the blocking signal generator switched off, adjust variable attenuator value by 1dB until to communication once cannot maintains. Then replace EUT by a power sensor, measure the power and recorded as P_{min} .

Test Frequency (MHz)	Wanted signal mean power from companion device (dBm)	Blocking signal frequency (MHz)	Blocking signal power (dBm)	PER
2402	$P_{min} + 26\text{dB}$	2380	-34	3.2%
	$P_{min} + 26\text{dB}$	2504		4.7%
	$P_{min} + 26\text{dB}$	2300		3.5%
	$P_{min} + 26\text{dB}$	2584		2.3%
2480	$P_{min} + 26\text{dB}$	2380		3.3%
	$P_{min} + 26\text{dB}$	2504		2.7%
	$P_{min} + 26\text{dB}$	2300		2.5%
	$P_{min} + 26\text{dB}$	2584		3.1%

Note: $P_{min} = -72\text{dBm}$

4 Test Setup Photos of the EUT

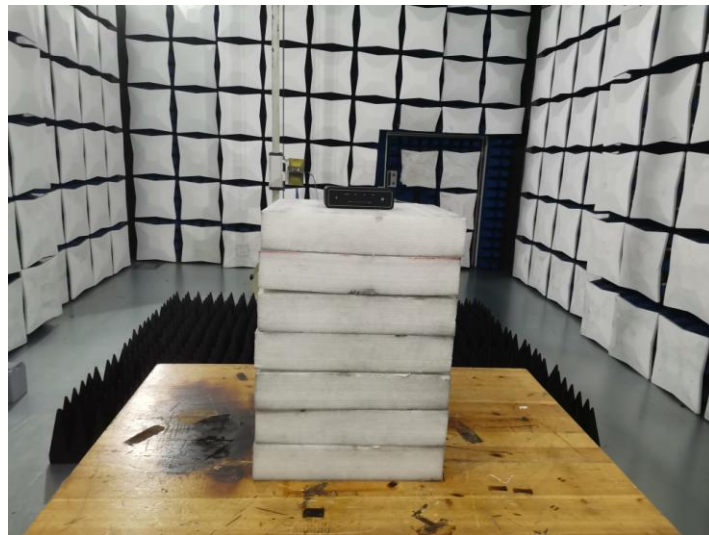

5 External and Internal Photos of the EUT

Reference to the test report No. CTL2104203011-WE

***** End of Report *****

6 ANNEX E

Information as required by EN 300 328 V2.2.2, clause 5.4.1

In accordance with EN 300 328, clause 5.4.1, the following information is provided by the supplier.

a) The type of modulation used by the equipment:

- FHSS
 Other forms of modulation

b) In case of FHSS modulation:

- In case of non-Adaptive Frequency Hopping equipment:
The number of Hopping Frequencies:
- In case of Adaptive Frequency Hopping Equipment:
The maximum number of Hopping Frequencies: 79
The minimum number of Hopping Frequencies: 15
- The (average) Dwell Time: 3.75ms

c) Adaptive / non-adaptive equipment:

- Non-adaptive Equipment
 Adaptive Equipment without the possibility to switch to a non-adaptive mode
 Adaptive Equipment which can also operate in a non-adaptive mode

d) In case of adaptive equipment:

The Channel Occupancy Time implemented by the equipment: ms

- The equipment has implemented an LBT based DAA mechanism
- In case of equipment using modulation different from FHSS:
 - The equipment is Frame Based equipment
 - The equipment is Load Based equipment
 - The equipment can switch dynamically between Frame Based and Load Based equipment
- The CCA time implemented by the equipment:
- The equipment has implemented an non-LBT based DAA mechanism
 The equipment can operate in more than one adaptive mode

e) In case of non-adaptive Equipment:

The maximum RF Output Power (e.i.r.p.): dBm

The maximum (corresponding) Duty Cycle: %

Equipment with dynamic behaviour, that behaviour is described here. (e.g. the different combinations of duty cycle and corresponding power levels to be declared):

f) The worst case operational mode for each of the following tests:

- RF Output Power
DH5,2DH5,3DH5
- Power Spectral Density
N/A
- Duty cycle, Tx-Sequence, Tx-gap
N/A
- Dwell time, Minimum Frequency Occupation & Hopping Sequence (only for FHSS equipment)
DH5,2DH5,3DH5
- Hopping Frequency Separation (only for FHSS equipment)
DH5,2DH5,3DH5
- Medium Utilisation
N/A
- Adaptivity
N/A
- Occupied Channel Bandwidth

DH5,2DH5,3DH5

- Transmitter unwanted emissions in the OOB domain
DH5,2DH5,3DH5
- Transmitter unwanted emissions in the spurious domain
DH5
- Receiver spurious emissions
DH5
- Receiver Blocking
DH5

g) The different transmit operating modes (tick all that apply):

- Operating mode 1: Single Antenna Equipment
 - Equipment with only 1 antenna
 - Equipment with 2 diversity antennas but only 1 antenna active at any moment in time
 - Smart Antenna Systems with 2 or more antennas, but operating in a (legacy) mode where only 1 antenna is used. (e.g. IEEE 802.11™ [i.3] legacy mode in smart antenna systems)
- Operating mode 2: Smart Antenna Systems - Multiple Antennas without beam forming
 - Single spatial stream / Standard throughput / (e.g. IEEE 802.11™ [i.3] legacy mode)
 - High Throughput (> 1 spatial stream) using Occupied Channel Bandwidth 1
 - High Throughput (> 1 spatial stream) using Occupied Channel Bandwidth 2
- Operating mode 3: Smart Antenna Systems - Multiple Antennas with beam forming
 - Single spatial stream / Standard throughput (e.g. IEEE 802.11™ [i.3] legacy mode)
 - High Throughput (> 1 spatial stream) using Occupied Channel Bandwidth 1
 - High Throughput (> 1 spatial stream) using Occupied Channel Bandwidth 2

h) In case of Smart Antenna Systems:

- The number of Receive chains:
- The number of Transmit chains:
 - Symmetrical power distribution
 - Asymmetrical power distribution

In case of beam forming, the maximum (additional) beam forming gain:

i) Operating Frequency Range(s) of the equipment:

- Operating Frequency Range 1: 2402MHz to 2480MHz
- Operating Frequency Range 2: MHz to MHz

NOTE: Add more lines if more Frequency Ranges are supported.

j) Occupied Channel Bandwidth(s):

- Occupied Channel Bandwidth 1: 1 MHz
- Occupied Channel Bandwidth 2: MHz

k) Type of Equipment (stand-alone, combined, plug-in radio device, etc.):

- Stand-alone
- Combined Equipment (Equipment where the radio part is fully integrated within another type of equipment)
- Plug-in radio device (Equipment intended for a variety of host systems)
- Other

l) The extreme operating conditions that apply to the equipment:

Operating temperature range: -20°C to +55°C

Operating voltage range: 6.3V to 8.5V AC DC

Details provided are for the: stand-alone equipment

- Combined (or host) equipment
- Test jig

m) The intended combination(s) of the radio equipment power settings and one or more antenna assemblies and their corresponding e.i.r.p levels:

- Antenna Type:

PCB Antenna

Antenna Gain: 0dBi

If applicable, additional beamforming gain (excluding basic antenna gain): dB

Temporary RF connector provided

No temporary RF connector provided

Dedicated Antennas (equipment with antenna connector)

Single power level with corresponding antenna(s)

Multiple power settings and corresponding antenna(s)

Number of different Power Levels:

Power Level 1:		dBm
Power Level 2:		dBm
Power Level 3:		dBm

n) For each of the Power Levels, provide the intended antenna assemblies, their corresponding gains (G) and the resulting e.i.r.p. levels also taking into account the beamforming gain (Y) if applicable

Power Level 1: dBm

Number of antenna assemblies provided for this power level:

Assembly #	Gain (dBi)	e.i.r.p. (dBm)	Part number or model name
1			
2			
3			
4			

Power Level 2: dBm

Number of antenna assemblies provided for this power level:

Assembly #	Gain (dBi)	e.i.r.p. (dBm)	Part number or model name
1			
2			
3			
4			

Power Level 3: dBm

Number of antenna assemblies provided for this power level:

Assembly #	Gain (dBi)	e.i.r.p. (dBm)	Part number or model name
1			
2			
3			
4			

- o) The nominal voltages of the stand-alone radio equipment or the nominal voltages of the combined (host) equipment or test jig in case of plug-in devices:

Details provided are for the: Stand-alone equipment
 Combined (or host) equipment
 Test jig

Supply Voltage AC mains State AC voltage V
 DC State DC voltage 7.4V

In case of DC, indicate the type of power source

- Internal Power Supply
 External Power Supply or AC/DC adapter
 Battery
 Other: DC 5V from PC

- p) Describe the test modes available which can facilitate testing:

- q) The equipment type (e.g. Bluetooth®, IEEE 802.11™ [i.3], proprietary, etc.):

Bluetooth®

- r) Geo-location capability supported by the equipment:

Yes

The geographical location determined by the equipment as defined in clause 4.3.1.13.2 or clause 4.3.2.12.2 is not accessible to the user

No

- s) Describe the minimum performance criteria that apply to the equipment (see clause 4.3.1.12.3 or clause 4.3.2.11.3):

N/A