



EN 301 893 RADIO TEST REPORT

For

Shenzhen Zhencheng Technology Co., Ltd.

Dashcam

Model No. : M60

Trade Name : N/A

Prepared for : Shenzhen Zhencheng Technology Co., Ltd.

Address : 3/F Building C, NO.2 ,Road 1, Shangxue Industrial Area, Bantian Street,
Longgang District, Shenzhen, China

Prepared by : Shenzhen RCT Testing Technology Co.,Ltd

Address : Room 2301 and 1305, No.2 Building, Lixiang Kewang Industrial Park, No.35
Guanlan Road, Longhua District, Shenzhen, China

Report No. : RCT202312140205R

Date of Receipt : Dec. 29, 2023

Date of Test : Dec. 14, 2023– Dec. 29, 2023

Contents

1.	General Information.....	5
1.1.	Description of Device (EUT).....	5
1.2.	Test Lab information.....	6
2.	Summary of test.....	16
2.1.	Test Standard description:.....	16
2.2.	Summary of test result.....	16
2.3.	Block Diagram of Configuration for test.....	17
2.4.	Test mode.....	17
2.5.	Test Conditions.....	18
2.6.	Measurement Uncertainty (95% confidence levels, k=2).....	19
2.7.	Test Equipment.....	19
3.	Carrier frequencies.....	21
3.1.	Limit.....	21
3.2.	Test Setup.....	21
3.3.	Test Procedure.....	21
3.4.	Test Result.....	22
4.	Occupied Channel Bandwidth.....	23
4.1.	Limit.....	23
4.2.	Test Setup.....	23
4.3.	Test Procedure.....	23
4.4.	Test Result.....	23
5.	RF output power.....	25
5.1.	Limit.....	25
5.2.	Test Setup.....	25
5.3.	Test Procedure.....	25
5.4.	Test Result.....	25
6.	Power Spectral Density.....	29
6.1.	Limit.....	29
6.2.	Test Setup.....	29
6.3.	Test Procedure.....	29
6.4.	Test Result.....	30
7.	Transmitter unwanted emissions outside the 5 GHz RLAN bands.....	31
7.1.	Limit.....	31
7.2.	Test Procedure.....	31
7.3.	Test Result.....	32
8.	Transmitter unwanted emissions within the 5 GHz RLAN bands.....	40
8.1.	Limit.....	40
8.2.	Test Setup.....	40
8.3.	Test Procedure.....	40
8.4.	Test Result.....	41
9.	Receiver Spurious emissions.....	71
9.1.	Limit.....	71

9.2.	Test Procedure.....	71
9.3.	Test Result.....	72
10.	DFS Parameters and Radar Waveforms Calibration.....	73
10.1.	DFS Parameters.....	73
10.2.	Radar Waveform Calibration.....	75
10.3.	DFS –Test Rarameter.....	75
10.4.	DFS –Test Results.....	78
11.	Adaptivity.....	81
11.1.	Limit.....	81
11.2.	Test Setup.....	81
11.3.	Test Procedure.....	82
11.4.	Test Result.....	82
12.	Receiver Blocking.....	114
12.1.	Limit.....	114
12.2.	Test Setup.....	114
12.3.	Test Procedure.....	114
12.4.	Test Result.....	115
13.	User Access Restrictions.....	116
14.	Photos of EUT.....	117

DECLARATION

Applicant : Shenzhen Zhencheng Technology Co., Ltd.
Manufacturer : Shenzhen Zhencheng Technology Co., Ltd.
Product : Dashcam
Model No. : M60
Trade Name : N/A
Power supply : DC 5V = 2A

Measurement Procedure Used:

ETSI EN 301 893 V2.1.1

The device described above is tested by Shenzhen RCT Testing Technology Co.,Ltd. The measurement results are contained in this test report and Shenzhen RCT Testing Technology Co.,Ltd. is assumed full of responsibility for the accuracy and completeness of these measurements. Also, this report shows that the EUT (Equipment Under Test) is technically compliant with the EN 301 893 requirements.

This report applies to above tested sample only and shall not be reproduced in part without written approval of Shenzhen RCT Testing Technology Co.,Ltd.

Prepared by :

Allen Shi

Editor

Reviewer :

Taylor Wang

Supervisor

Approved :

Hannah Li

Manager



1. General Information

1.1. Description of Device (EUT)

EUT Name	:	Dashcam
Trademark	:	N/A
Model No.	:	M60
Power supply	:	DC 5V from DC Port
Radio Technology	:	5G WiFi
Operation frequency	:	802.11a/n(HT20)/ac(HT20): 5180~5240MHz; 5260-5320MHz 802.11n(HT40)/ac(HT40): 5190~5230MHz; 5260-5320MHz 802.11ac(HT80): 5210MHz, 5290MHz
Modulation	:	IEEE 802.11n: OFDM (64QAM, 16QAM,QPSK,BPSK) IEEE 802.11a: OFDM (64QAM, 16QAM,QPSK,BPSK) IEEE 802.11ac: OFDM (64QAM, 16QAM,QPSK,BPSK)
Antenna Type	:	PCB Antenna, Maximum Gain is 2.5dBi
Applicant	:	Shenzhen Zhencheng Technology Co., Ltd.
Address	:	3/F Building C, NO.2 ,Road 1, Shangxue Industrial Area, Bantian Street, Longgang District, Shenzhen, China
Manufacturer	:	Shenzhen Zhencheng Technology Co., Ltd.
Address	:	3/F Building C, NO.2 ,Road 1, Shangxue Industrial Area, Bantian Street, Longgang District, Shenzhen, China
:	:	

1.2. Test Lab information

1.2.1 Laboratory Name

Shenzhen RCT Testing Technology Co., Ltd.

1.2.2 Location

Room 2301 and 1305, No.2 Building, Lixiang Kewang Industrial Park, No.35 Guanlan Road, Longhua District, Shenzhen, China

1.2.3 Test facility

JAN 08, 2014 File on Federal Communication
Commission Registration Number:178214
September 15, 2014
Certificated by IC
Registration Number:
8517 B

G.2 Information as required by ETSI EN 301 893 (V2.1.1), clause 5.4.1

In accordance with ETSI EN 301 893, clause 5.4.1, the following information is provided by the manufacturer.

a) The Nominal Channel Bandwidth(s):

Nominal Channel Bandwidth 1:..... MHz

Nominal Channel Bandwidth 2:..... MHz

Nominal Channel Bandwidth 3:..... MHz

The associated centre frequencies:

For Nominal Channel Bandwidth 1:

for the band 5 150 MHz to 5 350 MHz: MHz; MHz; MHz;..... MHz;

for the band 5 470 MHz to 5 725 MHz: MHz; MHz; MHz;..... MHz;

For Nominal Channel Bandwidth 2:

for the band 5 150 MHz to 5 350 MHz: MHz; MHz; MHz;..... MHz;

for the band 5 470 MHz to 5 725 MHz: MHz; MHz; MHz;..... MHz;

For Nominal Channel Bandwidth 3:

for the band 5 150 MHz to 5 350 MHz: MHz; MHz; MHz;..... MHz;

for the band 5 470 MHz to 5 725 MHz: MHz; MHz; MHz;..... MHz;

b) For equipment that support simultaneous transmissions in one or more channels:

The LBE equipment supports Option 1 as described in clause 4.2.7.3.2.3

The LBE equipment supports Option 2 as described in clause 4.2.7.3.2.3

The (maximum) number of channels used for these simultaneous transmissions:

These channels are adjacent channels: Yes No

In case of non-adjacent channels, whether or not these channels are in different sub-bands:

Yes No

for LBE equipment implementing option 1 (see clause 4.2.7.3.2.3), the number of channels used for multichannel operation when performing the test described in clause 5.4.9.3.2.3.1:

In case of simultaneous transmissions, further information defining the channels used for these simultaneous transmissions may be required.

c) The different transmit operating modes (see clause 5.3.3.2) (tick all that apply):

Operating mode 1: Single Antenna Equipment

a) Equipment with only 1 antenna

b) Equipment with diversity antennas but only 1 antenna active at any moment in time

c) Smart Antenna Systems with 2 or more antennas, but operating in a (legacy) mode where only 1 antenna is used.

Operating mode 2: Smart Antenna Systems - Multiple Antennas without beamforming

a) Single spatial stream/Standard throughput

- b) High Throughput (> 1 spatial stream) using Nominal Channel Bandwidth 1
- c) High Throughput (> 1 spatial stream) using Nominal Channel Bandwidth 2
- Operating mode 3: Smart Antenna Systems - Multiple Antennas with beamforming
 - a) Single spatial stream/Standard throughput
 - b) High Throughput (> 1 spatial stream) using Nominal Channel Bandwidth 1
 - c) High Throughput (> 1 spatial stream) using Nominal Channel Bandwidth 2
- d) In case of Smart Antenna Systems or multiple antenna systems:
 - The number of Receive chains:
 - The number of Transmit chains:
 - Equal power distribution among the transmit chains: Yes No
 - In case of beamforming, the maximum (additional) beamforming gain:.....dB
- e) TPC feature available:
 - Yes
 - No

f) For equipment with TPC range:
 The lowest and highest power level (or lowest and highest e.i.r.p. level in case of integrated antenna equipment),intended antenna assemblies and corresponding operating frequencyrange for the TPC range (or for each of the TPC ranges if more than one is implemented).

TPC range 1: Applicable Frequency Range:
 5 150 MHz to 5 350 MHz and 5 470 MHz to 5 725 MHz (Indoor)Simultaneous transmissions in both sub-bands: Yes No

5 470 MHz to 5 725 MHz only (Outdoor only)

Indicate whether the power levels specified are Transmitter Output Power levels or e.i.r.p.levels in case ofintegrated antenna equipment.

Power levels are specified for: Tx out e.i.r.p

If more than one transmit chain is present (e.g. in the case of smart antenna systems), thepower levels belowrepresent the power settings per active transmit chain (and per sub-band in case of simultaneous transmissions).

Table G.1: Power levels for TPC range 1

	Sub-band (MHz)	Operating Mode 1 (dBm)	Operating Mode 2 (dBm)	Operating Mode 3 (dBm)
Lowest setting (P _{low})	5 150 to 5 350
	5 470 to 5 725
Highest setting (P _{high})	5 150 to 5 350
	5 470 to 5 725

Beamforming possible: Yes No

Intended Antenna Assemblies:

Table G.2: Intended Antenna Assemblies for TPC range 1

Antenna Assembly name	Antenna Gain (dBi)	Operating Mode	Sub-band (MHz)	Beam forming gain (dB)	e.i.r.p. for Plow (dBm)	e.i.r.p. for Phigh (dBm)
<Antenna 1>	Mode 1	5 150 to 5 350
			5 470 to 5 725
		Mode 2	5 150 to 5 350
			5 470 to 5 725
		Mode 3	5 150 to 5 350
			5 470 to 5 725
<Antenna 2>	Mode 1	5 150 to 5 350
			5 470 to 5 725
		Mode 2	5 150 to 5 350
			5 470 to 5 725
		Mode 3	5 150 to 5 350
			5 470 to 5 725
<Antenna 3>	Mode 1	5 150 to 5 350
			5 470 to 5 725
		Mode 2	5 150 to 5 350
			5 470 to 5 725
		Mode 3	5 150 to 5 350
			5 470 to 5 725

 DFS Threshold level: dBm at the antenna connector

 in front of the antenna

TPC range 2: Applicable Frequency Range:

 5 150 MHz to 5 350 MHz and 5 470 MHz to 5 725 MHz (Indoor) Simultaneous transmissions in both sub-bands: Yes No

 5 470 MHz to 5 725 MHz only (Outdoor only)

Indicate whether the power levels specified are Transmitter Output Power levels or e.i.r.p. levels in case of integrated antenna equipment.

 Power levels are specified for: Tx out e.i.r.p

If more than one transmit chain is present (e.g. in the case of smart antenna systems), the power levels below represent the power settings per active transmit chain (and per sub-band in case of simultaneous transmissions).

Table G.3: Power levels for TPC range 2

Sub-band (MHz)	Operating Mode 1 (dBm)	Operating Mode 2 (dBm)	Operating Mode 3 (dBm)

Lowest setting (P _{low})	5 150 to 5 350
	5 470 to 5 725
Highest setting (P _{high})	5 150 to 5 350
	5 470 to 5 725

Beamforming possible: Yes No

Intended Antenna Assemblies:

Table G.4: Intended Antenna Assemblies for TPC range 2

Antenna Assembly name	Antenna Gain (dBi)	Operating Mode	Sub-band (MHz)	Beam forming gain (dB)	e.i.r.p. for P _{low} (dBm)	e.i.r.p. for P _{high} (dBm)
<Antenna 1>	Mode 1	5 150 to 5
			5 470 to 5
		Mode 2	5 150 to 5
			5 470 to 5
		Mode 3	5 150 to 5
			5 470 to 5
<Antenna 2>	Mode 1	5 150 to 5
			5 470 to 5
		Mode 2	5 150 to 5
			5 470 to 5
		Mode 3	5 150 to 5
			5 470 to 5
<Antenna 3>	Mode 1	5 150 to 5
			5 470 to 5
		Mode 2	5 150 to 5
			5 470 to 5
		Mode 3	5 150 to 5
			5 470 to 5

DFS Threshold level: dBm at the antenna connector
 in front of the antenna

g) For equipment without a TPC range:

Power Setting 1: Applicable Frequency Range:

- 5 150 MHz to 5 350 MHz and 5 470 MHz to 5 725 MHz (Indoor) Simultaneous transmissions in both sub-bands: Yes No

- 5 470 MHz to 5 725 MHz only (Outdoor only)

Indicate whether the power levels specified are Transmitter Output Power levels or e.i.r.p.levels in case of integrated antenna equipment.

Power levels are specified for: Tx out e.i.r.p.

If more than one transmit chain is present (e.g. in the case of smart antenna systems), the power levels below represent the power settings per active transmit chain (and per sub-band in case of simultaneous transmissions).

Table G.5: Maximum Transmitter Output Power for Power Setting 1

Sub-band (MHz)	Operating Mode 1 (dBm)	Operating Mode 2 (dBm)	Operating Mode 3 (dBm)
5 150 to 5 350
5 470 to 5 725

Beamforming possible: Yes No

Intended Antenna Assemblies:

Table G.6: Intended Antenna Assemblies for Power Setting 1

Antenna Assembly name	Antenna Gain (dBi)	Operating Mode	Sub-band (MHz)	Beam forming gain (dB)	e.i.r.p. (dBm)
<Antenna 1>	Mode 1	5 150 to 5 350
			5 470 to 5 725
		Mode 2	5 150 to 5 350
			5 470 to 5 725
		Mode 3	5 150 to 5 350
			5 470 to 5 725
<Antenna 2>	Mode 1	5 150 to 5 350
			5 470 to 5 725
		Mode 2	5 150 to 5 350
			5 470 to 5 725
		Mode 3	5 150 to 5 350
			5 470 to 5 725
<Antenna 3>	Mode 1	5 150 to 5 350
			5 470 to 5 725
		Mode 2	5 150 to 5 350
			5 470 to 5 725
		Mode 3	5 150 to 5 350
			5 470 to 5 725

DFS Threshold level: dBm at the antenna connector
 in front of the antenna

Power Setting 2: Applicable Frequency Range:

- 5 150 MHz to 5 350 MHz and 5 470 MHz to 5 725 MHz (Indoor)

Simultaneous transmissions in both sub-bands: Yes No

5 470 MHz to 5 725 MHz only (Outdoor only)

Indicate whether the power levels specified are Transmitter Output Power levels or e.i.r.p.levels in case of integrated antenna equipment.

Power levels are specified for: Tx out e.i.r.p.

If more than one transmit chain is present (e.g. in the case of smart antenna systems), the power levels below represent the power settings per active transmit chain (and per sub-band in case of simultaneous transmissions).

Table G.7: Maximum Transmitter Output Power for Power Setting 2

Sub-band (MHz)	Operating Mode 1 (dBm)	Operating Mode 2 (dBm)	Operating Mode 3 (dBm)
5 150 to 5 350
5 470 to 5 725

Beamforming possible:

Yes

No Intended Antenna Assemblies:

Table G.8: Intended Antenna Assemblies for Power Setting 2

Antenna Assembly name	Antenna Gain (dBi)	Operating Mode	Sub-band (MHz)	Beam forming gain (dB)	e.i.r.p. (dBm)
<Antenna 1>	Mode 1	5 150 to 5 350
			5 470 to 5 725
		Mode 2	5 150 to 5 350
			5 470 to 5 725
		Mode 3	5 150 to 5 350
			5 470 to 5 725
<Antenna 2>	Mode 1	5 150 to 5 350
			5 470 to 5 725
		Mode 2	5 150 to 5 350
			5 470 to 5 725
		Mode 3	5 150 to 5 350
			5 470 to 5 725
<Antenna 3>	Mode 1	5 150 to 5 350
			5 470 to 5 725
		Mode 2	5 150 to 5 350
			5 470 to 5 725
		Mode 3	5 150 to 5 350
			5 470 to 5 725

DFS Threshold level: dBm at the antenna connector

in front of the antenna

h) The DFS related operating mode(s) of the equipment:

- Master
- Slave with radar detection
- Slave without radar detection

If the equipment has more than one operating mode, tick all that apply.

i) User access restrictions (please check box below to confirm):

- the equipment is constructed to comply with the requirements contained in clause 4.2.9 in ETSI EN 301 893 V2.1.1.

j) For equipment with Off-Channel CAC functionality:

The equipment has an "Off-Channel CAC" function:

- Yes
- No

If yes, specify the "Off-Channel CAC Time".

For channels outside the 5 600 MHz to 5 650 MHz range:..... hours

If applicable, for channels (partially) within the 5 600 MHz to 5 650 MHz range:

k) The equipment can operate in ad-hoc mode:

- no ad-hoc operation
- ad-hoc operation in the frequency range 5 150 MHz to 5 250 MHz without DFS
- ad-hoc operation with DFS

If more than 1 is applicable, tick all that apply.

l) Operating Frequency Range(s):

Range 1: 5 150 MHz to 5 350 MHz and 5 470 MHz to 5 725 MHz

Range 2: 5 470 MHz to 5 725 MHz

Range 3: 5 150 MHz to 5 250 MHz (ad-hoc without DFS)

Range 4: other, please specify:.....

If the equipment has more than one Operating Frequency Range, tick all that apply.

m) The extreme operating temperature and supply voltage range that apply to the equipment:

- 20 °C to +55 °C (Outdoor & Indoor usage)
- 20 °C to +35 °C (Indoor usage only)
- Other:

The supply voltages of the stand-alone radio equipment or the supply voltages of the combined (host) equipment or test jig in case of plug-in devices:

- Details provided are for the:
- stand-alone equipment
 - combined (or host) equipment
 - test jig

Supply Voltage AC mains State AC voltage: Minimum: ... Nominal: ... Maximum: ...

DC State DC voltage Minimum: ... Nominal: ... Maximum: ...

In case of DC, indicate the type of power source:

- Internal Power Supply
- External Power Supply or AC/DC adapter

- Battery
 - Nickel Cadmium
 - Alkaline
 - Nickel-Metal Hydride
 - Lithium-Ion
 - Lead acid (Vehicle regulated)
 - Other
- n) The test sequence/test software used (see also ETSI EN 301 893 (V2.1.1), clause 5.3.1.2):

.....
.....
.....

- o) Type of Equipment:
- Stand-alone
 - Combined Equipment (Equipment where the radio part is fully integrated within another type of equipment)
 - Plug-in radio device (Equipment intended for a variety of host systems)
 - Other
- p) Adaptivity (Channel Access Mechanism):
- Frame Based Equipment
 - Load Based Equipment

- q) With regards to Adaptivity for Frame Based Equipment/
- The Frame Based Equipment operates as an Initiating Device
 - The Frame Based Equipment operates as an Responding Device
 - The Frame Based Equipment can operate as an Initiating Device and as a Responding Device

The Frame Based Equipment has implemented the following Fixed Frame Period(s):

..... ms
..... ms
..... Ms

- r) With regards to Adaptivity for Load Based Equipment/
- The Load Based Equipment operates as a Supervising Device
 - The Load Based Equipment operates as a Supervised Device
 - The Load Based Equipment can operate as a Supervising and as a Supervised Device
 - The Load Based Equipment makes use of note 1 in table 7 or note 1 in table 8 of ETSI EN 301 893 V2.1.1
 - The Load Based Equipment, when operating as a Supervising Device, makes use of note 2 in table 7 of ETSI EN 301 893 V2.1.1

The Priority Classes implemented by the Load Based Equipment When operating as a Supervising Device

- Priority Class 4 (Highest priority)

- Priority Class 3
- Priority Class 2
- Priority Class 1
(Lowest priority) When operating as a Supervised Device
- Priority Class 4 (Highest priority)
 - Priority Class 3
 - Priority Class 2
 - Priority Class 1 (Lowest priority)
- The Load Based Equipment operates as an Initiating Device
- The Load Based Equipment operates as an Responding Device
- The Load Based Equipment can operate as an Initiating Device and as a Responding Device

With regard to Energy Detection Threshold, the Load Based Equipment has implemented either option 1 of clause 4.2.7.3.2.5 of ETSI EN 301 893 V2.1.1 or option 2 of clause 4.2.7.3.2.5 of ETSI EN 301 893 V2.1.1:

- Option 1
- Option 2

Specify which protocol has been implemented: IEEE 802.11™ Other:

s) The equipment supports a geo-location capability as defined in clause 4.2.10 of ETSI EN 301 893 V2.1.1:

- Yes No

t) The minimum performance criteria (see ETSI EN 301 893 V1.9.1, clause 4.2.8.3) that corresponds to the intended use of the equipment.

.....

u) The theoretical maximum radio performance of the equipment (e.g. maximum throughput) (see ETSI EN 301 893 V2.1.1, clause 5.4.9.3.1):

.....

2. Summary of test

2.1. Test Standard description:

ETSI EN 301 893 V2.1.1: 5 GHz RLAN; Harmonised Standard covering the essential requirements of article 3.2 of Directive 2014/53/EU.

2.2. Summary of test result

Technical requirements :

The following essential requirements and test specifications are relevant to the presumption of conformity under Article 3.2 of Directive 2014/53/EU			
No	Test Parameter	Clause No	Results
1	Carrier frequencies	4.2.1	PASS
2	Nominal, and occupied, channel bandwidth	4.2.2	PASS
3	RF output power	4.2.3	PASS
4	Transmit Power Control (TPC)	4.2.3	N/A
5	Power Density	4.2.3	PASS
6	Transmitter unwanted emissions outside the 5 GHz RLAN bands	4.2.4.1	PASS
7	Transmitter unwanted emissions within the 5 GHz RLAN bands	4.2.4.2	PASS
8	Receiver spurious emissions	4.2.5	PASS
9	DFS: Channel Availability Check	4.2.6.2.2	PASS
10	DFS: Off-Channel CAC - Radar Detection Threshold	4.2.6.2.3	PASS
11	DFS: Off-Channel CAC - Detection Probability	4.2.6.2.3	PASS
12	DFS: In service Monitoring	4.2.6.2.4	PASS
13	DFS: Channel shutdown	4.2.6.2.5	PASS
14	DFS: Non-occupancy period	4.2.6.2.6	PASS
15	DFS: Uniform spreading	4.2.6.2.7	PASS
16	Adaptivity	4.2.7	PASS
17	Receiver Blocking	4.2.8	PASS
18	User Access Restrictions	4.2.9	PASS
19	Geo-location capability	4.2.10	N/A

Note:

1. N/A is an abbreviation for Not Applicable and means this test item is not applicable for this device according to the technology characteristic of device.
2. All transmit chains were tested, and only worst test data are listed in report.
3. Decision rules for the conclusion of this test report: decision by actual test data without considering measurement uncertainty.

2.3. Block Diagram of Configuration for test



2.4. Test mode

The special RF test software was used to control EUT work in Continuous BT TXmode, and select test channel, wireless mode.

U-NII-1:

Tested mode, channel, and data rate information			
Mode	Data rate(Mbps) see Note	Channel	Frequency (MHz)
IEEE 802.11a	6	CH36	5180
	6	CH44	5200
	6	CH48	5240
IEEE 802.11ac VHT20	6.5	CH36	5180
	6.5	CH44	5200
	6.5	CH48	5240
IEEE 802.11ac VHT40	13.5	CH38	5190
	13.5	CH46	5230
IEEE 802.11ac VHT80	433.3	CH42	5210
IEEE 802.11n HT20	6.5	CH36	5180
	6.5	CH44	5200
	6.5	CH48	5240
IEEE 802.11n HT40	13.5	CH38	5190
	13.5	CH46	5230

Note: According exploratory test and product specification EUT will have maximum output power in those data rate, so those data rate were used for all test.

U-NII-2A:

Tested mode, channel, and data rate information			
Mode	Data rate(Mbps) see Note	Channel	Frequency (MHz)
IEEE 802.11a	6	CH52	5260
	6	CH56	5280
	6	CH64	5320
IEEE 802.11n HT20	6.5	CH52	5260
	6.5	CH56	5280
	6.5	CH64	5320
IEEE 802.11n HT40	13.5	CH54	5270
	13.5	CH62	5310
IEEE 802.11ac VHT20	6.5	CH52	5260
	6.5	CH56	5280
	6.5	CH64	5320
IEEE 802.11ac VHT40	13.5	CH54	5270
	13.5	CH62	5310
IEEE 802.11ac VHT80	433.3	CH58	5290

Note: According exploratory test and product specification EUT will have maximum output power in those data rate, so those data rate were used for all test.

2.5. Test Conditions

	Normal Conditions	Extreme Conditions
Temperature range	15-35°C	0°C and 50°C
Humidity range	20-75%	20-75%
Pressure range	86-106kPa	86-106kPa
Power supply	DC 3.7V from lithium battery	3.2V and 4.2V(declared by the manufacturer)

Note 1: The test procedure described in clause 5.1 of EN300 328 was used for extreme test procedure.

2: The Extreme Temperature and Extreme Voltages declared by the manufacturer.

2.6.Measurement Uncertainty (95% confidence levels, k=2)

Test Item	Uncertainty	U _{cispr}
Uncertainty for Conduction emission test	2.50dB	3.8 dB
Uncertainty for Radiation Emission test	3.04 dB (Distance: 3m Polarize: V)	5.2 dB
	3.02 dB (Distance: 3m Polarize: H)	
Uncertainty for Power Clamp Test	3.94 dB	4.5 dB
Uncertainty for Flicker test	0.05%	N/A
Uncertainty for Harmonic test	1.8%	N/A

2.7.Test Equipment

Equipment	Manufacture	Model No.	Serial No.	Last cal.	Cal Interval
3m Semi-Anechoic	ETS-LINDGREN	N/A	SEL0017	2023.12.13	1Year
Spectrum analyzer	Agilent	E4407B	MY46185649	2023.12.13	1Year
Receiver	R&S	ESCI	1166.5950K03 -1011	2023.12.13	1Year
Receiver	R&S	ESCI	101202	2023.12.13	1Year
Bilog Antenna	Schwarzbeck	VULB 9168	VULB9168-43 8	2023.12.13	1Year
Horn Antenna	EMCO	3115	640201028-06	2023.12.13	1Year
Active Loop Antenna	Beijing Daze	ZN30900A	SEL0097	2023.12.13	1Year
Cable	Resenberger	N/A	No.1	2023.12.13	1Year
Cable	SCHWARZBECK	N/A	No.2	2023.12.13	1Year
Cable	SCHWARZBECK	N/A	No.3	2023.12.13	1Year
Pre-amplifier	Schwarzbeck	BBV9743	9743-019	2023.12.13	1Year
Pre-amplifier	R&S	AFS33-1800 2650-30-8P- 44	SEL0080	2023.12.13	1Year

Base station	Agilent	E5515C	GB44300243	2023.12.13	1 Year
Temperature controller	Terchy	MHQ	120	2023.12.13	1Year
Power divider	Anritsu	K240C	020346	2023.12.13	1 Year
Signal Generator	HP	83732B	VS3449051	2023.12.13	1 Year
Attenuator	Agilent	8491B	MY39262165	2023.12.13	1 Year
vector Signal Generator	Agilent	E4438C	MY49070163	2023.12.13	1 Year
splitter	Mini-Circuits	ZAP-50W	NN256400424	2023.12.13	1 Year
Directional Coupler	Agilent	87300C	MY44300299	2023.12.13	1 Year
vector Signal Generator	Agilent	E4438C	US44271917	2023.12.13	1 Year
X-series USB Peak and Average Power Sensor	Agilent	U2021XA	MY54080020	2023.12.13	1 Year
X-series USB Peak and Average Power Sensor	Agilent	U2021XA	MY54110001	2023.12.13	1 Year
X-series USB Peak and Average Power Sensor	Agilent	U2021XA	MY53480008	2023.12.13	1 Year
X-series USB Peak and Average Power Sensor	Agilent	U2021XA	MY54080019	2023.12.13	1 Year
4 Ch.Simultaneous Sampling 14 Bits 2 MS/s	Agilent	U2531A	TPS-KBS1054 063507	2023.12.13	1 Year
4 Ch.Simultaneous Sampling 14 Bits 2 MS/s	Agilent	U2531A	TPS-KBS1054 063513	2023.12.13	1 Year
splitter	Mini	PS3-7	4463	2023.12.13	1 Year
Signal Analyzer	Agilent	N9010A	MY48030494	2023.12.13	1 Year

3.4. Test Result

U-NII-1

Condition	Mode	Frequency (MHz)	Antenna	Measured Frequency (MHz)	Frequency Error (Hz)	Deviation (ppm)	Limit (ppm)	Verdict
NVNT	a	5180	Ant1	5180	0	0	20	Pass
NVNT	a	5200	Ant1	5199.98	-20000	-3.85	20	Pass
NVNT	a	5240	Ant1	5240	0	0	20	Pass
NVNT	ac20	5180	Ant1	5179.94	-60000	-11.58	20	Pass
NVNT	ac20	5200	Ant1	5199.96	-40000	-7.69	20	Pass
NVNT	ac20	5240	Ant1	5239.96	-40000	-7.63	20	Pass
NVNT	ac40	5190	Ant1	5190	0	0	20	Pass
NVNT	ac40	5230	Ant1	5230	0	0	20	Pass
NVNT	ac80	5210	Ant1	5210	0	0	20	Pass
NVNT	n20	5180	Ant1	5179.98	-20000	-3.86	20	Pass
NVNT	n20	5200	Ant1	5199.96	-40000	-7.69	20	Pass
NVNT	n20	5240	Ant1	5239.96	-40000	-7.63	20	Pass
NVNT	n40	5190	Ant1	5190	0	0	20	Pass
NVNT	n40	5230	Ant1	5230	0	0	20	Pass

U-NII-2A

Condition	Mode	Frequency (MHz)	Antenna	Measured Frequency (MHz)	Frequency Error (Hz)	Deviation (ppm)	Limit (ppm)	Verdict
NVNT	a	5260	Ant1	5259.98	-20000	-3.8	20	Pass
NVNT	a	5280	Ant1	5279.98	-20000	-3.79	20	Pass
NVNT	a	5320	Ant1	5319.98	-20000	-3.76	20	Pass
NVNT	ac20	5260	Ant1	5259.96	-40000	-7.6	20	Pass
NVNT	ac20	5280	Ant1	5279.98	-20000	-3.79	20	Pass
NVNT	ac20	5320	Ant1	5319.92	-80000	-15.04	20	Pass
NVNT	ac40	5270	Ant1	5270	0	0	20	Pass
NVNT	ac40	5310	Ant1	5309.96	-40000	-7.53	20	Pass
NVNT	ac80	5290	Ant1	5290	0	0	20	Pass
NVNT	n20	5260	Ant1	5259.96	-40000	-7.6	20	Pass
NVNT	n20	5280	Ant1	5279.98	-20000	-3.79	20	Pass
NVNT	n20	5320	Ant1	5320	0	0	20	Pass
NVNT	n40	5270	Ant1	5270	0	0	20	Pass
NVNT	n40	5310	Ant1	5310	0	0	20	Pass

4. Occupied Channel Bandwidth

4.1. Limit

The Nominal Channel Bandwidth is the widest band of frequencies, inclusive of guardbands, assigned to a single channel.

The Nominal Channel Bandwidth shall be at least 5 MHz at all times. The Occupied Channel Bandwidth shall be between 80 % and 100 % of the declared Nominal Channel Bandwidth. In case of smart antenna systems (devices with multiple transmit chains) each of the transmit chains shall meet this requirement.

NOTE: During an established communication, a device is allowed to operate temporarily in a mode where its Occupied Channel Bandwidth may be reduced to as low as 40 % of its Nominal Channel Bandwidth with a minimum of 4 MHz.

4.2. Test Setup

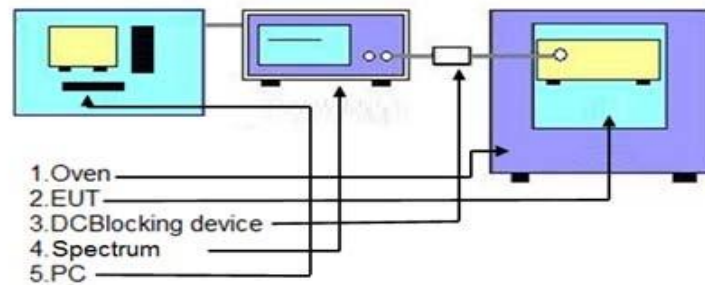

4.3. Test Procedure

Refer to ETSI EN 301 893 V2.1.1 Clause 5.4.3.

4.4. Test Result

PASS.

U-NII-1

Condition	Mode	Frequency (MHz)	Antenna	Center Frequency (MHz)	OBW (MHz)	Verdict
NVNT	a	5180	Ant1	5180	16.464	Pass
NVNT	a	5200	Ant1	5200	16.464	Pass
NVNT	a	5240	Ant1	5240	16.464	Pass
NVNT	ac20	5180	Ant1	5180	17.662	Pass
NVNT	ac20	5200	Ant1	5200	17.662	Pass
NVNT	ac20	5240	Ant1	5240	17.662	Pass
NVNT	ac40	5190	Ant1	5190.08	36.124	Pass
NVNT	ac40	5230	Ant1	5230.08	36.124	Pass
NVNT	ac80	5210	Ant1	5210.08	75.604	Pass
NVNT	n20	5180	Ant1	5180	17.662	Pass
NVNT	n20	5200	Ant1	5200	17.662	Pass
NVNT	n20	5240	Ant1	5240	17.662	Pass
NVNT	n40	5190	Ant1	5190.08	36.124	Pass
NVNT	n40	5230	Ant1	5230.08	36.124	Pass
NVNT	n40	5230	Ant1	5230.04	36.523	Pass

U-NII-2A

Condition	Mode	Frequency (MHz)	Antenna	Center Frequency (MHz)	OBW (MHz)	Verdict
NVNT	a	5260	Ant1	5260	16.464	Pass
NVNT	a	5280	Ant1	5280	16.464	Pass
NVNT	a	5320	Ant1	5320	16.464	Pass
NVNT	ac20	5260	Ant1	5260	17.662	Pass
NVNT	ac20	5280	Ant1	5280	17.662	Pass
NVNT	ac20	5320	Ant1	5320	17.662	Pass
NVNT	ac40	5270	Ant1	5270.08	36.124	Pass
NVNT	ac40	5310	Ant1	5310.04	36.044	Pass
NVNT	ac80	5290	Ant1	5290	75.764	Pass
NVNT	n20	5260	Ant1	5260.02	17.622	Pass
NVNT	n20	5280	Ant1	5280	17.662	Pass
NVNT	n20	5320	Ant1	5320	17.662	Pass
NVNT	n40	5270	Ant1	5270.08	36.124	Pass
NVNT	n40	5310	Ant1	5310.04	36.044	Pass

5. RF output power

5.1. Limit

Frequency range [MHz]	Mean e.i.r.p. limit [dBm]		Mean e.i.r.p. density limit [dBm/MHz]	
	with TPC	without TPC	with TPC	without TPC
5 150 to 5 350	23	20/23 (see note 1)	10	7/10 (see note 2)
5 470 to 5 725	30 (see note 3)	27 (see note 3)	17 (see note 3)	14 (see note 3)

NOTE 1: The applicable limit is 20 dBm, except for transmissions whose nominal bandwidth falls completely within the band 5 150 MHz to 5 250 MHz, in which case the applicable limit is 23 dBm.

NOTE 2: The applicable limit is 7 dBm/MHz, except for transmissions whose nominal bandwidth falls completely within the band 5 150 MHz to 5 250 MHz, in which case the applicable limit is 10 dBm/MHz.

NOTE 3: Slave devices without a Radar Interference Detection function shall comply with the limits for the band 5 250 MHz to 5 350 MHz.

5.2. Test Setup

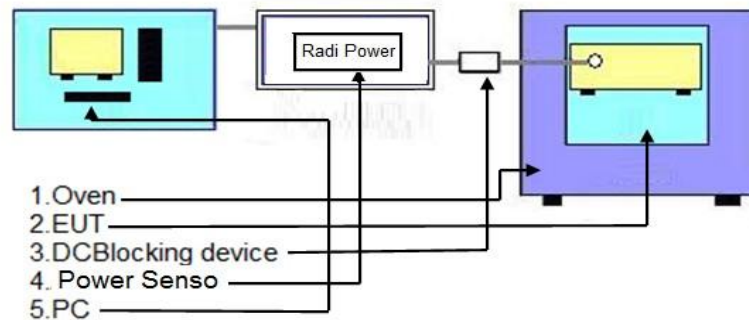

The EUT was directly connected to the Power Sensor & Power meter

5.3. Test Procedure

Refer to ETSI EN 301 893 V2.1.1 Clause 5.4.4.

5.4. Test Result

See the next page for test data.

U-NII-1

Condition	Mode	Frequency (MHz)	Antenna	Max EIRP (dBm)	Limit (dBm)	Verdict
NVHT	a	5180	Ant1	13.78	23	Pass
NVHT	a	5200	Ant1	13.5	23	Pass
NVHT	a	5240	Ant1	13.85	23	Pass
NVLT	a	5180	Ant1	13.83	23	Pass
NVLT	a	5200	Ant1	13.46	23	Pass
NVLT	a	5240	Ant1	13.92	23	Pass
NVNT	a	5180	Ant1	13.82	23	Pass
NVNT	a	5200	Ant1	14.1	23	Pass
NVNT	a	5240	Ant1	13.53	23	Pass
NVHT	ac20	5180	Ant1	13.42	23	Pass
NVHT	ac20	5200	Ant1	13.46	23	Pass
NVHT	ac20	5240	Ant1	14.69	23	Pass
NVLT	ac20	5180	Ant1	13.69	23	Pass
NVLT	ac20	5200	Ant1	13.86	23	Pass
NVLT	ac20	5240	Ant1	13.71	23	Pass
NVNT	ac20	5180	Ant1	13.74	23	Pass
NVNT	ac20	5200	Ant1	13.63	23	Pass
NVNT	ac20	5240	Ant1	14.01	23	Pass
NVHT	ac40	5190	Ant1	12.79	23	Pass
NVHT	ac40	5230	Ant1	13.19	23	Pass
NVLT	ac40	5190	Ant1	13.35	23	Pass
NVLT	ac40	5230	Ant1	13.9	23	Pass
NVNT	ac40	5190	Ant1	13.82	23	Pass
NVNT	ac40	5230	Ant1	14.21	23	Pass
NVHT	ac80	5210	Ant1	13.79	23	Pass
NVLT	ac80	5210	Ant1	13.9	23	Pass
NVNT	ac80	5210	Ant1	13.48	23	Pass
NVHT	n20	5180	Ant1	13.7	23	Pass
NVHT	n20	5200	Ant1	13.78	23	Pass
NVHT	n20	5240	Ant1	14.05	23	Pass
NVLT	n20	5180	Ant1	13.96	23	Pass
NVLT	n20	5200	Ant1	13.74	23	Pass
NVLT	n20	5240	Ant1	14.08	23	Pass
NVNT	n20	5180	Ant1	14.22	23	Pass
NVNT	n20	5200	Ant1	14.16	23	Pass
NVNT	n20	5240	Ant1	13.63	23	Pass
NVHT	n40	5190	Ant1	13.92	23	Pass
NVHT	n40	5230	Ant1	14.4	23	Pass
NVLT	n40	5190	Ant1	14.3	23	Pass
NVLT	n40	5230	Ant1	14.26	23	Pass
NVNT	n40	5190	Ant1	13.45	23	Pass
NVNT	n40	5230	Ant1	13.33	23	Pass

U-NII-2A

Condition	Mode	Frequency (MHz)	Antenna	Max EIRP (dBm)	Limit (dBm)	Verdict
NVHT	a	5260	Ant1	13.11	23	Pass
NVHT	a	5280	Ant1	13.18	23	Pass
NVHT	a	5320	Ant1	13.98	23	Pass
NVLT	a	5260	Ant1	13.36	23	Pass
NVLT	a	5280	Ant1	13.06	23	Pass
NVLT	a	5320	Ant1	13.89	23	Pass
NVNT	a	5260	Ant1	13.75	23	Pass
NVNT	a	5280	Ant1	14.21	23	Pass
NVNT	a	5320	Ant1	13.99	23	Pass
NVHT	ac20	5260	Ant1	12.77	23	Pass
NVHT	ac20	5280	Ant1	12.87	23	Pass
NVHT	ac20	5300	Ant1	12.99	23	Pass
NVLT	ac20	5260	Ant1	13.34	23	Pass
NVLT	ac20	5280	Ant1	13.41	23	Pass
NVLT	ac20	5300	Ant1	13.88	23	Pass
NVNT	ac20	5260	Ant1	13.69	23	Pass
NVNT	ac20	5280	Ant1	13.41	23	Pass
NVNT	ac20	5300	Ant1	13.95	23	Pass
NVHT	ac40	5270	Ant1	14.19	23	Pass
NVHT	ac40	5310	Ant1	14.47	23	Pass
NVLT	ac40	5270	Ant1	14.09	23	Pass
NVLT	ac40	5310	Ant1	13.81	23	Pass
NVNT	ac40	5270	Ant1	13.66	23	Pass
NVNT	ac40	5310	Ant1	13.97	23	Pass
NVHT	ac80	5290	Ant1	14.23	23	Pass
NVLT	ac80	5290	Ant1	14.05	23	Pass
NVNT	ac80	5290	Ant1	13.79	23	Pass
NVHT	n20	5260	Ant1	14.02	23	Pass
NVHT	n20	5280	Ant1	14.34	23	Pass
NVHT	n20	5320	Ant1	13.65	23	Pass
NVLT	n20	5260	Ant1	13.45	23	Pass
NVLT	n20	5280	Ant1	13.8	23	Pass
NVLT	n20	5320	Ant1	14.18	23	Pass
NVNT	n20	5260	Ant1	13.97	23	Pass
NVNT	n20	5280	Ant1	14.71	23	Pass
NVNT	n20	5320	Ant1	14.75	23	Pass
NVHT	n40	5270	Ant1	13.37	23	Pass
NVHT	n40	5310	Ant1	13.91	23	Pass
NVLT	n40	5270	Ant1	13.33	23	Pass
NVLT	n40	5310	Ant1	13.17	23	Pass
NVNT	n40	5270	Ant1	13.38	23	Pass
NVNT	n40	5310	Ant1	13.15	23	Pass

6. Power Spectral Density

6.1. Limit

Frequency range [MHz]	Mean e.i.r.p. limit [dBm]		Mean e.i.r.p. density limit [dBm/MHz]	
	with TPC	without TPC	with TPC	without TPC
5 150 to 5 350	23	20/23 (see note 1)	10	7/10 (see note 2)
5 470 to 5 725	30 (see note 3)	27 (see note 3)	17 (see note 3)	14 (see note 3)

NOTE 1: The applicable limit is 20 dBm, except for transmissions whose nominal bandwidth falls completely within the band 5 150 MHz to 5 250 MHz, in which case the applicable limit is 23 dBm.

NOTE 2: The applicable limit is 7 dBm/MHz, except for transmissions whose nominal bandwidth falls completely within the band 5 150 MHz to 5 250 MHz, in which case the applicable limit is 10 dBm/MHz.

NOTE 3: Slave devices without a Radar Interference Detection function shall comply with the limits for the band 5 250 MHz to 5 350 MHz.

6.2. Test Setup

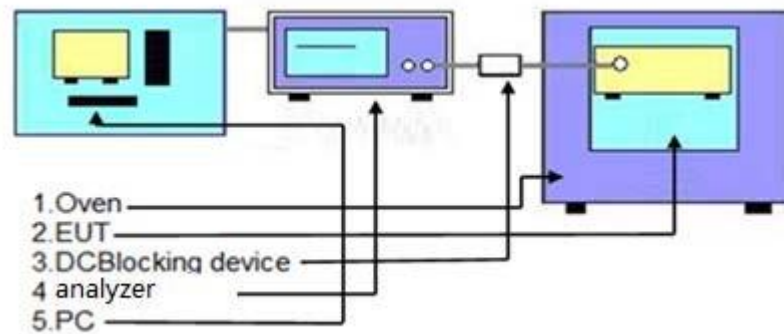

The EUT was directly connected to the analyzer

6.3. Test Procedure

Refer to ETSI EN 301 893 V2.1.1 Clause 5.4.4

6.4. Test Result

U-NII-1

Condition	Mode	Frequency (MHz)	Antenna	Max PSD (dBm/MHz)	Limit (dBm/MHz)	Verdict
NVNT	a	5180	Ant1	3.86	10	Pass
NVNT	a	5200	Ant1	2.68	10	Pass
NVNT	a	5240	Ant1	2.14	10	Pass
NVNT	ac20	5180	Ant1	3.67	10	Pass
NVNT	ac20	5200	Ant1	2.28	10	Pass
NVNT	ac20	5240	Ant1	2.27	10	Pass
NVNT	ac40	5190	Ant1	-0.52	10	Pass
NVNT	ac40	5230	Ant1	-0.37	10	Pass
NVNT	ac80	5210	Ant1	-4.14	10	Pass
NVNT	n20	5180	Ant1	4.05	10	Pass
NVNT	n20	5200	Ant1	2.71	10	Pass
NVNT	n20	5240	Ant1	2.08	10	Pass
NVNT	n40	5190	Ant1	-1.04	10	Pass
NVNT	n40	5230	Ant1	-1.16	10	Pass

U-NII-2A

Condition	Mode	Frequency (MHz)	Antenna	Max PSD (dBm/MHz)	Limit (dBm/MHz)	Verdict
NVNT	a	5260	Ant1	2.27	10	Pass
NVNT	a	5280	Ant1	3.41	10	Pass
NVNT	a	5320	Ant1	6.78	10	Pass
NVNT	ac20	5260	Ant1	2.2	10	Pass
NVNT	ac20	5280	Ant1	2.31	10	Pass
NVNT	ac20	5320	Ant1	-0.71	10	Pass
NVNT	ac40	5270	Ant1	-0.85	10	Pass
NVNT	ac40	5310	Ant1	0.21	10	Pass
NVNT	ac80	5290	Ant1	-2.43	10	Pass
NVNT	n20	5260	Ant1	5.44	10	Pass
NVNT	n20	5280	Ant1	3.51	10	Pass
NVNT	n20	5320	Ant1	4.09	10	Pass
NVNT	n40	5270	Ant1	-1.02	10	Pass
NVNT	n40	5310	Ant1	-0.66	10	Pass

7. Transmitter unwanted emissions outside the 5 GHz RLAN bands

7.1. Limit

The level of unwanted emission shall not exceed the limits given in table .

Frequency range	Maximum power	Bandwidth
30 MHz to 47 MHz	-36 dBm	100 kHz
47 MHz to 74 MHz	-54 dBm	100 kHz
74 MHz to 87,5 MHz	-36 dBm	100 kHz
87,5 MHz to 118 MHz	-54 dBm	100 kHz
118 MHz to 174 MHz	-36 dBm	100 kHz
174 MHz to 230 MHz	-54 dBm	100 kHz
230 MHz to 470 MHz	-36 dBm	100 kHz
470 MHz to 862 MHz	-54 dBm	100 kHz
862 MHz to 1 GHz	-36 dBm	100 kHz
1 GHz to 5,15 GHz	-30 dBm	1 MHz
5,35 GHz to 5,47 GHz	-30 dBm	1 MHz
5,725 GHz to 26 GHz	-30 dBm	1 MHz

7.2. Test Procedure

Radiated Measurement:

- (1) The EUT was placed on a 1.5m high table in the chamber and turned on in continuously TX mode.
- (2) All the spurious emissions from 30MHz to 26GHz at 3m distance was measured and recorded with receive antenna in both vertical and horizontal by rotating the turntable and by lowering the receive antenna, and the spectrum analyzer was set as below
RBW:100KHz VBW:300KHz for 30MHz-1000MHz
RBW:1MHz VBW:1MHz for above 1GHz
Detector mode: Peak mode
Sweep time: Auto
- (3) The EUT was then removed and replaced with a substitution antenna in the same position and the substitution antenna must have the same polarization with the receive antenna.
- (4) A signal which have the same frequency obtained in step 2 was fed to the substitution antenna ,the receive antenna was raised and lowered to obtain a maximum reading at the test receiver, the level of the signal generator was adjusted until the measured field strength level in step 2 was obtained, recorded the level of the signal generator.
- (5) Repeated step 4 with both antenna polarizations
- (6) The spurious emissions is equal to the power supplied by the signal generator and corrections due to the gain of the substitution antenna and the cable loss between the signal generator and the substitution antenna.

7.3. Test Result

U-NII-1 :					
Test Mode: IEEE 802.11a Tx in Lowest channel (5180MHz)					
Frequency (MHz)	Antenna polarization	Result (dBm)	Limit (dBm)	Margin (dB)	Conclusion
256.02	H	-61.85	-36	-25.85	Pass
433.38	H	-65.77	-36	-29.77	Pass
6040.59	H	-47.73	-30	-17.73	Pass
10343.06	H	-36.80	-30	-6.80	Pass
251.63	V	-59.52	-36	-23.52	Pass
435.35	V	-60.24	-36	-24.24	Pass
6686.46	V	-44.74	-30	-14.74	Pass
10362.64	V	-36.81	-30	-6.81	Pass
Test Mode: IEEE 802.11a Tx in highest channel (5240MHz)					
Frequency (MHz)	Antenna polarization	Result (dBm)	Limit (dBm)	Margin (dB)	Conclusion
252.93	H	-62.25	-36	-26.25	Pass
431.38	H	-65.79	-36	-29.79	Pass
6035.84	H	-47.84	-30	-17.84	Pass
10478.75	H	-37.22	-30	-7.22	Pass
251.35	V	-60.09	-36	-24.09	Pass
430.06	V	-60.22	-36	-24.22	Pass
6686.54	V	-44.50	-30	-14.50	Pass
10479.02	V	-37.12	-30	-7.12	Pass

Test Mode: IEEE 802.11n HT20 Tx in Lowest channel (5180MHz)					
Frequency (MHz)	Antenna polarization	Result (dBm)	Limit (dBm)	Margin (dB)	Conclusion
252.91	H	-62.16	-36	-26.16	Pass
437.20	H	-66.11	-36	-30.11	Pass
6035.07	H	-47.62	-30	-17.62	Pass
10345.12	H	-37.45	-30	-7.45	Pass
250.52	V	-60.41	-36	-24.41	Pass
437.36	V	-60.12	-36	-24.12	Pass
6690.95	V	-44.79	-30	-14.79	Pass
10363.14	V	-37.51	-30	-7.51	Pass
Test Mode: IEEE 802.11n HT20 Tx in highest channel (5240MHz)					
249.48	H	-62.28	-36	-26.28	Pass
433.55	H	-65.40	-36	-29.40	Pass
6040.58	H	-47.72	-30	-17.72	Pass
10482.98	H	-37.18	-30	-7.18	Pass
248.57	V	-59.75	-36	-23.75	Pass
430.18	V	-59.49	-36	-23.49	Pass
6688.51	V	-44.16	-30	-14.16	Pass
10481.08	V	-37.69	-30	-7.69	Pass
Test Mode: IEEE 802.11ac VHT20 Tx in Lowest channel (5180MHz)					
Frequency (MHz)	Antenna polarization	Result (dBm)	Limit (dBm)	Margin (dB)	Conclusion
255.93	H	-61.80	-36	-25.80	Pass
430.78	H	-65.40	-36	-29.40	Pass
6039.48	H	-47.83	-30	-17.83	Pass
10341.50	H	-36.95	-30	-6.95	Pass
249.28	V	-59.85	-36	-23.85	Pass
436.15	V	-60.17	-36	-24.17	Pass
6689.91	V	-44.11	-30	-14.11	Pass
10360.23	V	-37.14	-30	-7.14	Pass
Test Mode: IEEE 802.11ac VHT20 Tx in highest channel (5240MHz)					
251.49	H	-61.83	-36	-25.83	Pass
430.25	H	-65.94	-36	-29.94	Pass
6040.82	H	-47.99	-30	-17.99	Pass
10484.71	H	-36.68	-30	-6.68	Pass
250.83	V	-60.29	-36	-24.29	Pass

433.87	V	-60.14	-36	-24.14	Pass
6689.50	V	-44.60	-30	-14.60	Pass
10483.00	V	-36.80	-30	-6.80	Pass

Test Mode: IEEE 802.11n HT40 Tx in Lowest channel (5190MHz)					
Frequency (MHz)	Antenna polarization	Result (dBm)	Limit (dBm)	Margin (dB)	Conclusion
246.49	H	-62.74	-36	-26.74	Pass
429.07	H	-66.12	-36	-30.12	Pass
6039.34	H	-47.93	-30	-17.93	Pass
10382.34	H	-37.21	-30	-7.21	Pass
256.09	V	-60.20	-36	-24.20	Pass
428.45	V	-60.30	-36	-24.30	Pass
6690.47	V	-45.05	-30	-15.05	Pass
10383.89	V	-37.55	-30	-7.55	Pass

Test Mode: IEEE 802.11n HT40 Tx in highest channel (5230MHz)					
255.94	H	-62.43	-36	-26.43	Pass
434.24	H	-66.19	-36	-30.19	Pass
6038.53	H	-48.13	-30	-18.13	Pass
10462.19	H	-37.36	-30	-7.36	Pass
254.01	V	-60.16	-36	-24.16	Pass
430.74	V	-59.84	-36	-23.84	Pass
6689.21	V	-44.85	-30	-14.85	Pass
10464.82	V	-37.20	-30	-7.20	Pass

Test Mode: IEEE 802.11ac VHT40 Tx in Lowest channel (5190MHz)					
Frequency (MHz)	Antenna polarization	Result (dBm)	Limit (dBm)	Margin (dB)	Conclusion
253.55	H	-61.92	-36	-25.92	Pass
434.19	H	-66.20	-36	-30.20	Pass
6037.45	H	-48.20	-30	-18.20	Pass
10384.99	H	-37.29	-30	-7.29	Pass
252.92	V	-59.79	-36	-23.79	Pass
427.53	V	-59.94	-36	-23.94	Pass
6685.21	V	-44.33	-30	-14.33	Pass
10379.16	V	-37.33	-30	-7.33	Pass

Test Mode: IEEE 802.11ac VHT40 Tx in highest channel (5230MHz)					
247.95	H	-61.87	-36	-25.87	Pass
437.32	H	-65.85	-36	-29.85	Pass

6038.52	H	-47.86	-30	-17.86	Pass
10464.35	H	-37.19	-30	-7.19	Pass
251.04	V	-60.08	-36	-24.08	Pass
427.92	V	-59.82	-36	-23.82	Pass
6694.50	V	-44.59	-30	-14.59	Pass
10460.19	V	-37.01	-30	-7.01	Pass

Test Mode: IEEE 802.11ac VHT80 Tx (5210MHz)					
Frequency (MHz)	Antenna polarization	Result (dBm)	Limit (dBm)	Margin (dB)	Conclusion
253.48	H	-61.78	-36	-25.78	Pass
434.91	H	-65.56	-36	-29.56	Pass
6039.12	H	-47.87	-30	-17.87	Pass
10480.61	H	-36.58	-30	-6.58	Pass
252.10	V	-60.37	-36	-24.37	Pass
434.35	V	-59.53	-36	-23.53	Pass
6687.06	V	-44.70	-30	-14.70	Pass
10483.42	V	-36.79	-30	-6.79	Pass

U-NII-2A:					
Test Mode: IEEE 802.11a Tx in Lowest channel (5260MHz)					
Frequency (MHz)	Antenna polarization	Result (dBm)	Limit (dBm)	Margin (dB)	Conclusion
253.26	H	-62.71	-36	-26.71	Pass
434.15	H	-66.22	-36	-30.22	Pass
6039.12	H	-48.56	-30	-18.56	Pass
10520.74	H	-37.30	-30	-7.30	Pass
255.64	V	-60.26	-36	-24.26	Pass
436.76	V	-59.49	-36	-23.49	Pass
6688.37	V	-44.23	-30	-14.23	Pass
10518.15	V	-37.71	-30	-7.71	Pass
Test Mode: IEEE 802.11a Tx in highest channel (5320MHz)					
Frequency (MHz)	Antenna polarization	Result (dBm)	Limit (dBm)	Margin (dB)	Conclusion
250.27	H	-62.42	-36	-26.42	Pass
435.76	H	-65.41	-36	-29.41	Pass
6036.37	H	-48.03	-30	-18.03	Pass
10642.47	H	-37.31	-30	-7.31	Pass
252.62	V	-59.94	-36	-23.94	Pass
433.50	V	-60.03	-36	-24.03	Pass
6690.17	V	-44.32	-30	-14.32	Pass
10640.85	V	-37.41	-30	-7.41	Pass

Test Mode: IEEE 802.11n HT20 Tx in Lowest channel (5260MHz)					
Frequency (MHz)	Antenna polarization	Result (dBm)	Limit (dBm)	Margin (dB)	Conclusion
246.25	H	-62.07	-36	-26.07	Pass
436.93	H	-65.79	-36	-29.79	Pass
6034.87	H	-48.33	-30	-18.33	Pass
10519.81	H	-37.10	-30	-7.10	Pass
247.72	V	-60.24	-36	-24.24	Pass
429.89	V	-60.17	-36	-24.17	Pass
6689.27	V	-44.53	-30	-14.53	Pass
10520.38	V	-37.02	-30	-7.02	Pass
Test Mode: IEEE 802.11n HT20 Tx in highest channel (5320MHz)					
249.10	H	-61.82	-36	-25.82	Pass
427.82	H	-66.02	-36	-30.02	Pass
6034.31	H	-48.18	-30	-18.18	Pass
10642.84	H	-37.22	-30	-7.22	Pass
249.58	V	-60.04	-36	-24.04	Pass
428.92	V	-59.56	-36	-23.56	Pass
6691.14	V	-44.22	-30	-14.22	Pass
10638.59	V	-37.02	-30	-7.02	Pass
Test Mode: IEEE 802.11ac VHT20 Tx in Lowest channel (5260MHz)					
Frequency (MHz)	Antenna polarization	Result (dBm)	Limit (dBm)	Margin (dB)	Conclusion
252.05	H	-62.55	-36	-26.55	Pass
431.66	H	-65.92	-36	-29.92	Pass
6040.64	H	-48.38	-30	-18.38	Pass
10524.60	H	-36.68	-30	-6.68	Pass
248.57	V	-59.79	-36	-23.79	Pass
429.62	V	-59.72	-36	-23.72	Pass
6693.38	V	-44.96	-30	-14.96	Pass
10523.19	V	-37.36	-30	-7.36	Pass
Test Mode: IEEE 802.11ac VHT20 Tx in highest channel (5320MHz)					
248.71	H	-62.49	-36	-26.49	Pass
429.53	H	-66.09	-36	-30.09	Pass
6036.05	H	-48.29	-30	-18.29	Pass
10644.25	H	-37.30	-30	-7.30	Pass
255.90	V	-59.87	-36	-23.87	Pass

428.09	V	-59.87	-36	-23.87	Pass
6685.95	V	-44.88	-30	-14.88	Pass
10639.92	V	-37.65	-30	-7.65	Pass

Test Mode: IEEE 802.11n HT40 Tx in Lowest channel (5270MHz)					
Frequency (MHz)	Antenna polarization	Result (dBm)	Limit (dBm)	Margin (dB)	Conclusion
247.25	H	-61.83	-36	-25.83	Pass
428.62	H	-65.73	-36	-29.73	Pass
6041.30	H	-48.57	-30	-18.57	Pass
10542.48	H	-37.52	-30	-7.52	Pass
247.63	V	-60.28	-36	-24.28	Pass
433.68	V	-60.32	-36	-24.32	Pass
6691.32	V	-44.13	-30	-14.13	Pass
10541.04	V	-37.02	-30	-7.02	Pass

Test Mode: IEEE 802.11n HT40 Tx in highest channel (5310MHz)					
Frequency (MHz)	Antenna polarization	Result (dBm)	Limit (dBm)	Margin (dB)	Conclusion
249.85	H	-62.21	-36	-26.21	Pass
437.05	H	-65.78	-36	-29.78	Pass
6043.71	H	-48.57	-30	-18.57	Pass
10619.46	H	-36.92	-30	-6.92	Pass
250.74	V	-59.80	-36	-23.80	Pass
431.91	V	-59.77	-36	-23.77	Pass
6694.77	V	-44.80	-30	-14.80	Pass
10620.70	V	-37.44	-30	-7.44	Pass

Test Mode: IEEE 802.11ac VHT40 Tx in Lowest channel (5270MHz)					
Frequency (MHz)	Antenna polarization	Result (dBm)	Limit (dBm)	Margin (dB)	Conclusion
249.40	H	-62.55	-36	-26.55	Pass
433.66	H	-65.49	-36	-29.49	Pass
6038.12	H	-48.49	-30	-18.49	Pass
10543.12	H	-36.93	-30	-6.93	Pass
253.60	V	-59.86	-36	-23.86	Pass
433.55	V	-59.57	-36	-23.57	Pass
6686.94	V	-44.86	-30	-14.86	Pass
10539.36	V	-37.70	-30	-7.70	Pass

Test Mode: IEEE 802.11ac VHT40 Tx in highest channel (5310MHz)					
Frequency (MHz)	Antenna polarization	Result (dBm)	Limit (dBm)	Margin (dB)	Conclusion
249.95	H	-62.07	-36	-26.07	Pass
430.62	H	-65.53	-36	-29.53	Pass

6036.88	H	-47.68	-30	-17.68	Pass
10618.31	H	-37.01	-30	-7.01	Pass
246.31	V	-60.10	-36	-24.10	Pass
427.54	V	-60.37	-36	-24.37	Pass
6692.30	V	-44.91	-30	-14.91	Pass
10619.98	V	-36.98	-30	-6.98	Pass

Test Mode: IEEE 802.11ac VHT80 Tx (5290MHz)					
Frequency (MHz)	Antenna polarization	Result (dBm)	Limit (dBm)	Margin (dB)	Conclusion
246.71	H	-62.09	-36	-26.09	Pass
433.04	H	-65.33	-36	-29.33	Pass
6038.54	H	-48.42	-30	-18.42	Pass
10583.47	H	-37.16	-30	-7.16	Pass
247.20	V	-60.38	-36	-24.38	Pass
433.88	V	-59.71	-36	-23.71	Pass
6685.62	V	-44.89	-30	-14.89	Pass
10584.87	V	-36.88	-30	-6.88	Pass

8. Transmitter unwanted emissions within the 5 GHz RLAN bands

8.1. Limit

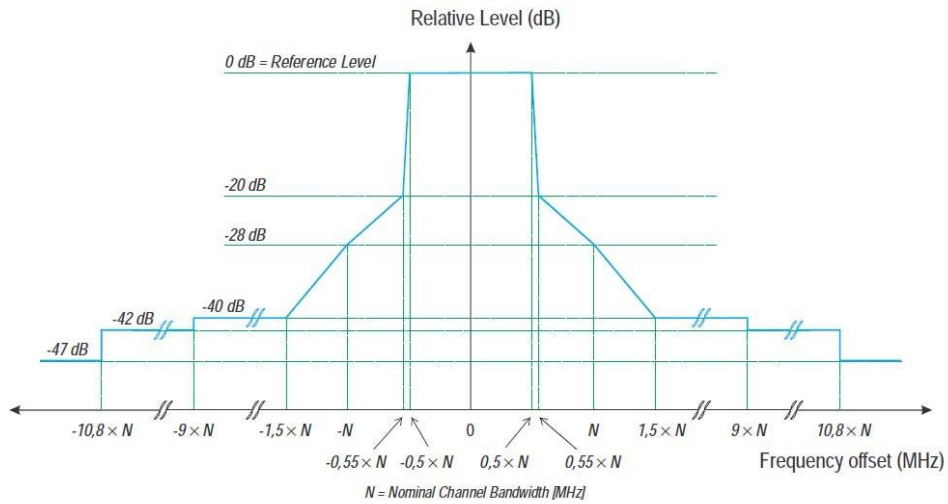

8.2. Test Setup

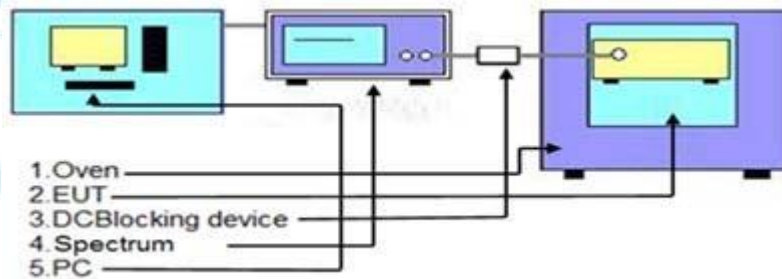

The EUT was programmed to be in continuously transmitting mode.

8.3. Test Procedure

Refer to ETSI EN 301 893 V2.1.1 Clause 5.4.6.

8.4. Test Result

U-NII-1

Condition	Mode	Frequency (MHz)	Antenna	Sub Band	Worst EIB Frequency (MHz)	Level (dB)	Limit (dB)	Verdict
NVNT	a	5180	Ant1	Band1	5209.96	-48.54	-39.95	Pass
NVNT	a	5180	Ant1	Band2	5506.92	-57.14	-47	Pass
NVNT	a	5200	Ant1	Band1	5170.24	-48.8	-39.71	Pass
NVNT	a	5200	Ant1	Band2	5523.04	-56.35	-47	Pass
NVNT	a	5240	Ant1	Band1	5210.2	-50.04	-39.76	Pass
NVNT	a	5240	Ant1	Band2	5496.67	-55.93	-47	Pass
NVNT	ac20	5180	Ant1	Band1	5209.52	-49.13	-39.42	Pass
NVNT	ac20	5180	Ant1	Band2	5495.19	-57.08	-47	Pass
NVNT	ac20	5200	Ant1	Band1	5170.96	-48.75	-38.84	Pass
NVNT	ac20	5200	Ant1	Band2	5477.65	-56.62	-47	Pass
NVNT	ac20	5240	Ant1	Band1	5210.8	-48.58	-39.03	Pass
NVNT	ac20	5240	Ant1	Band2	5476.22	-56.35	-47	Pass
NVNT	ac40	5190	Ant1	Band1	5252.08	-47.52	-40	Pass
NVNT	ac40	5190	Ant1	Band2	5686.85	-55.11	-47	Pass
NVNT	ac40	5230	Ant1	Band1	5288.52	-47.68	-39.11	Pass
NVNT	ac40	5230	Ant1	Band2	5724.8	-55.46	-47	Pass
NVNT	ac80	5210	Ant1	Band1	5307.88	-38.82	-33.36	Pass
NVNT	ac80	5210	Ant1	Band2	5499.73	-50.78	-40	Pass
NVNT	n20	5180	Ant1	Band1	5209.96	-48.96	-39.95	Pass
NVNT	n20	5180	Ant1	Band2	5472.04	-57.3	-47	Pass
NVNT	n20	5200	Ant1	Band1	5170.04	-47.95	-39.95	Pass
NVNT	n20	5200	Ant1	Band2	5474.34	-56.34	-47	Pass
NVNT	n20	5240	Ant1	Band1	5210.52	-50.18	-39.37	Pass
NVNT	n20	5240	Ant1	Band2	5496.32	-56.57	-47	Pass
NVNT	n40	5190	Ant1	Band1	5253.28	-47.72	-40	Pass
NVNT	n40	5190	Ant1	Band2	5706.59	-54.23	-47	Pass
NVNT	n40	5230	Ant1	Band1	5298.32	-48.95	-40	Pass
NVNT	n40	5230	Ant1	Band2	5714.85	-54.28	-47	Pass

Frequency: 5180.00 MHz

Transmitter unwanted emissions within the 5 GHz RLAN bands

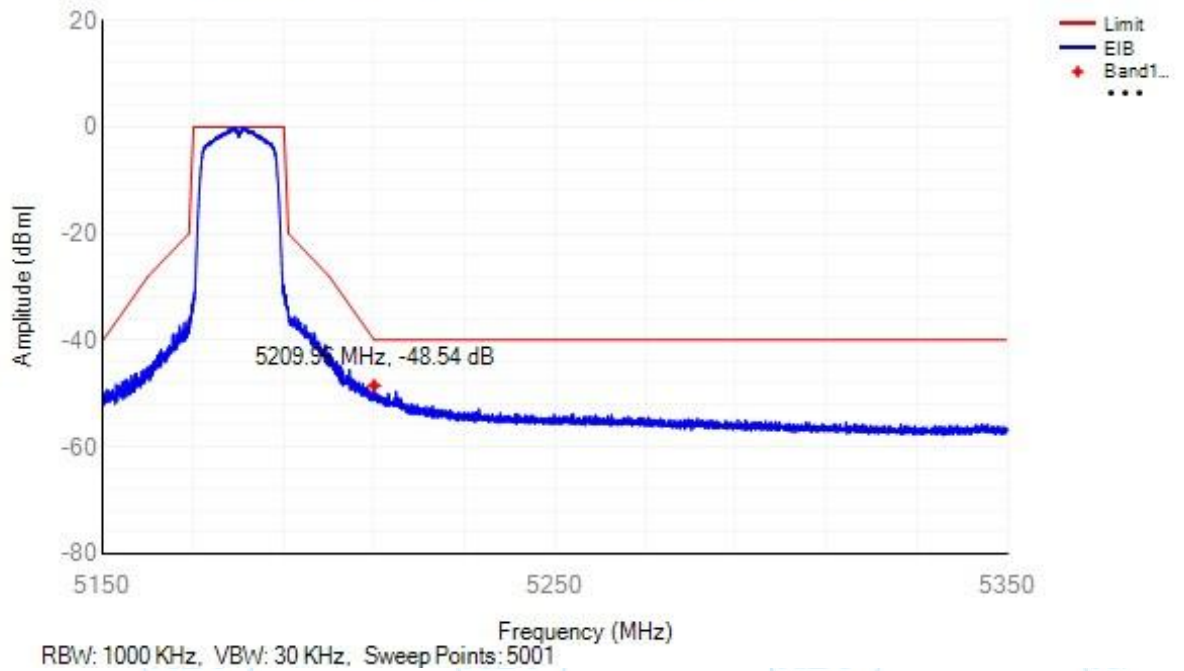

Tx. Emissions EIB NVNT a 5180MHz Sub Band2

Frequency: 5180.00 MHz

Transmitter unwanted emissions within the 5 GHz RLAN bands

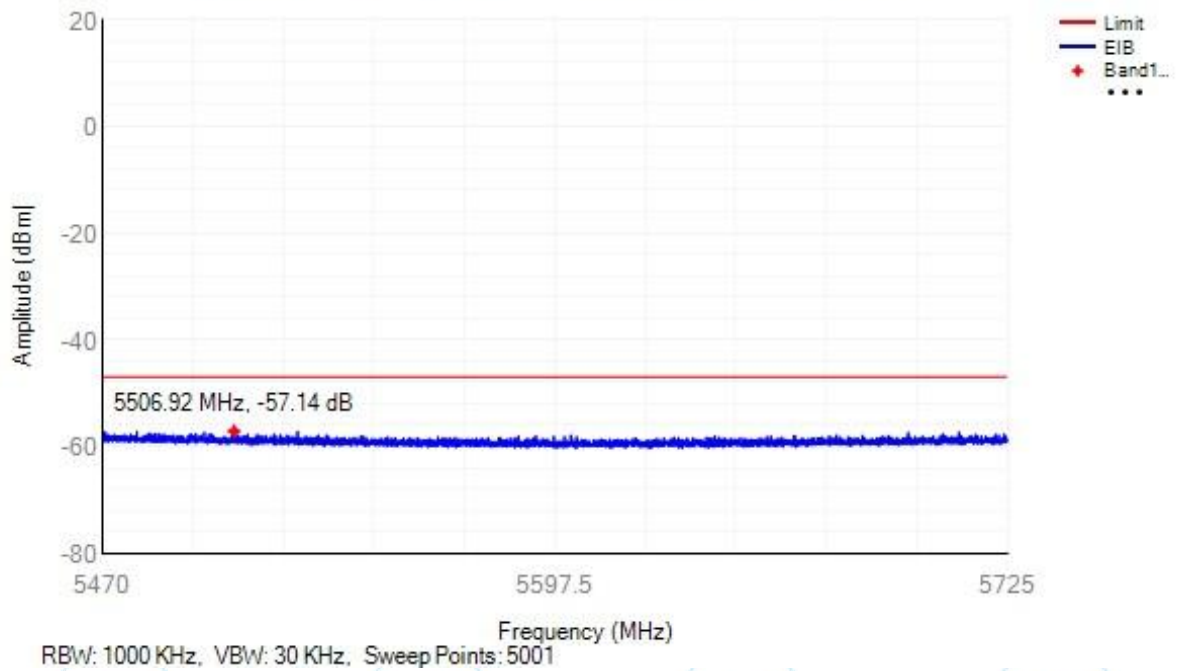

Frequency: 5200.00 MHz

Transmitter unwanted emissions within the 5 GHz RLAN bands

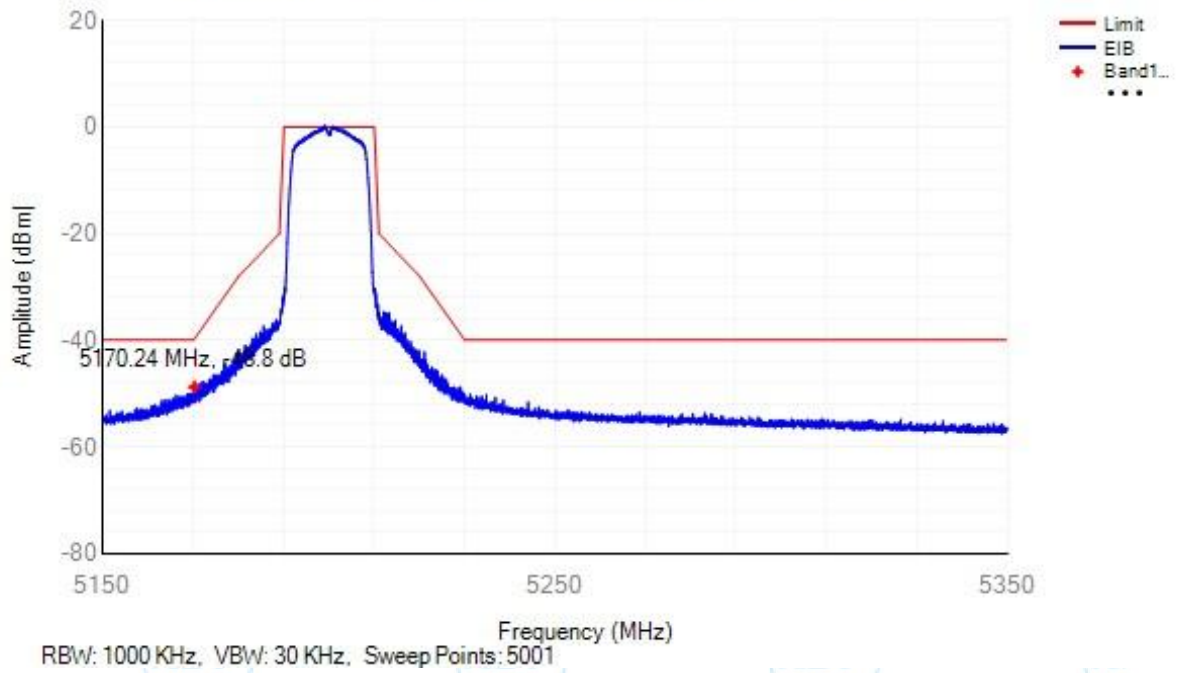

Tx. Emissions EIB NVNT a 5200MHz Sub Band2

Frequency: 5200.00 MHz

Transmitter unwanted emissions within the 5 GHz RLAN bands



Frequency: 5249.00 MHz

Transmitter unwanted emissions within the 5 GHz RLAN bands

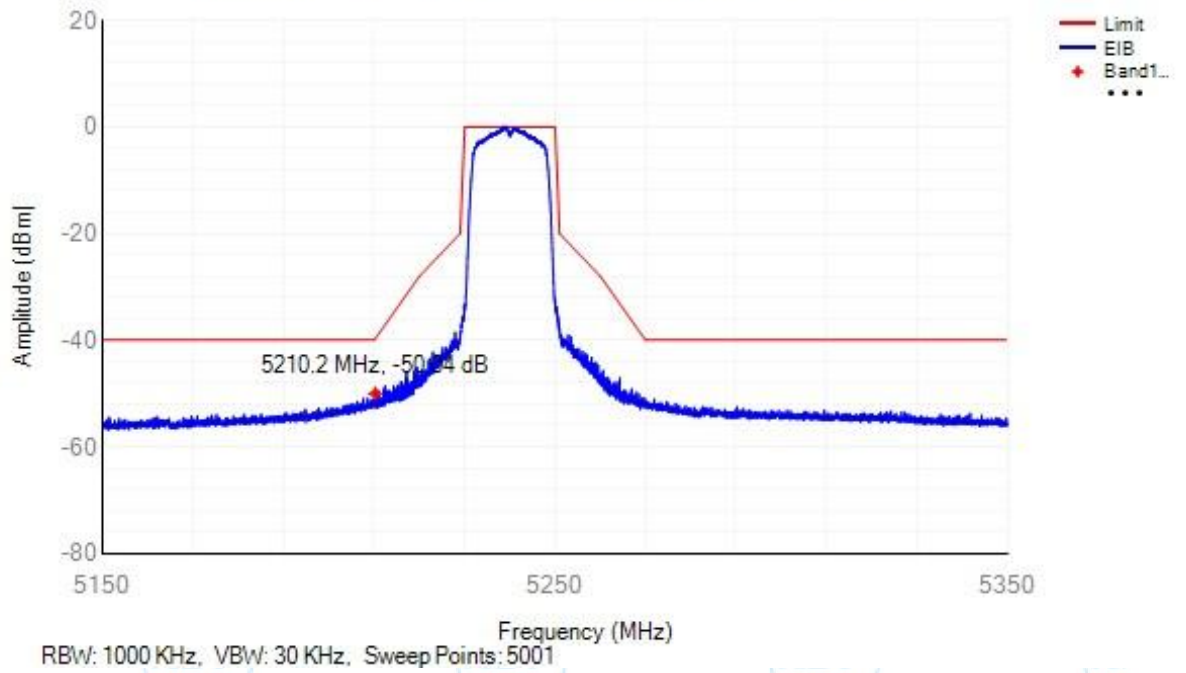

Tx. Emissions EIB NVNT a 5240MHz Sub Band2

Frequency: 5249.00 MHz

Transmitter unwanted emissions within the 5 GHz RLAN bands

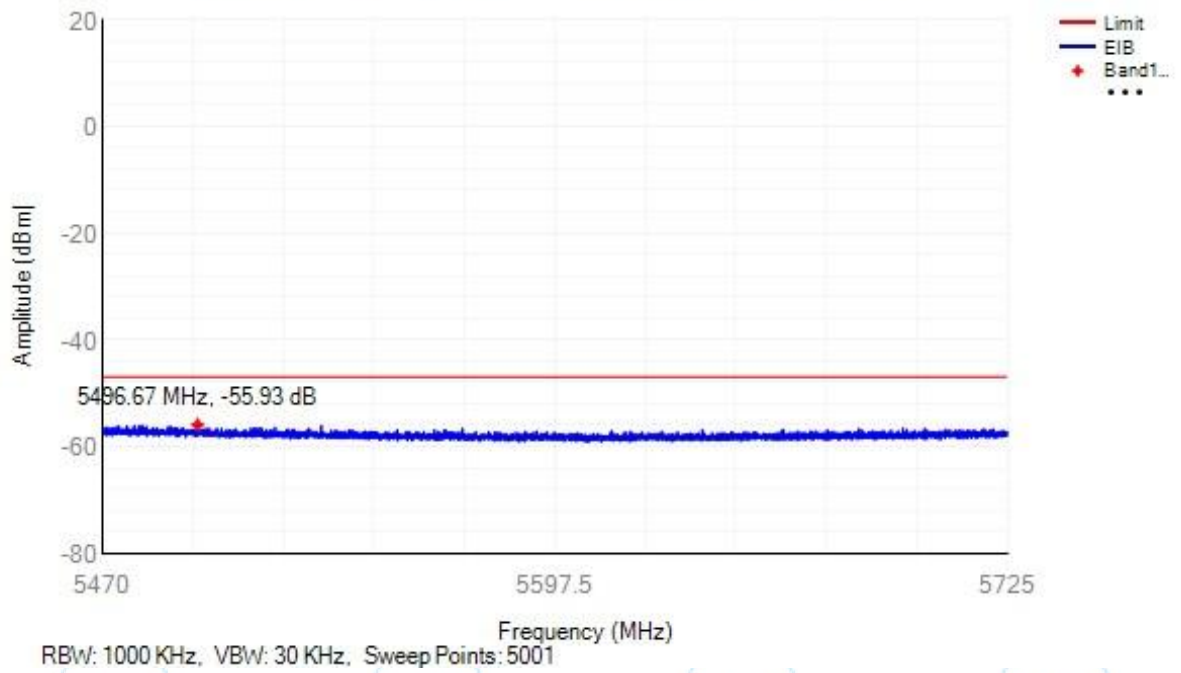

Frequency: 5180.00 MHz

Transmitter unwanted emissions within the 5 GHz RLAN bands

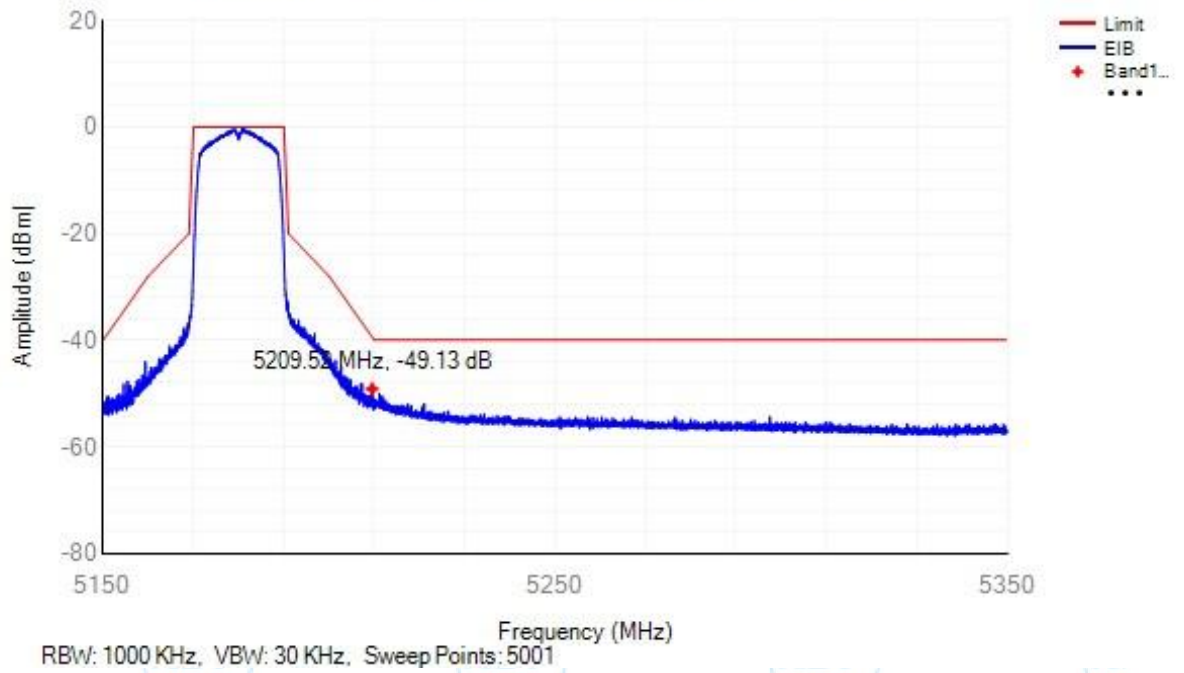

Tx. Emissions EIB NVNT ac20 5180MHz Sub Band2

Frequency: 5180.00 MHz

Transmitter unwanted emissions within the 5 GHz RLAN bands

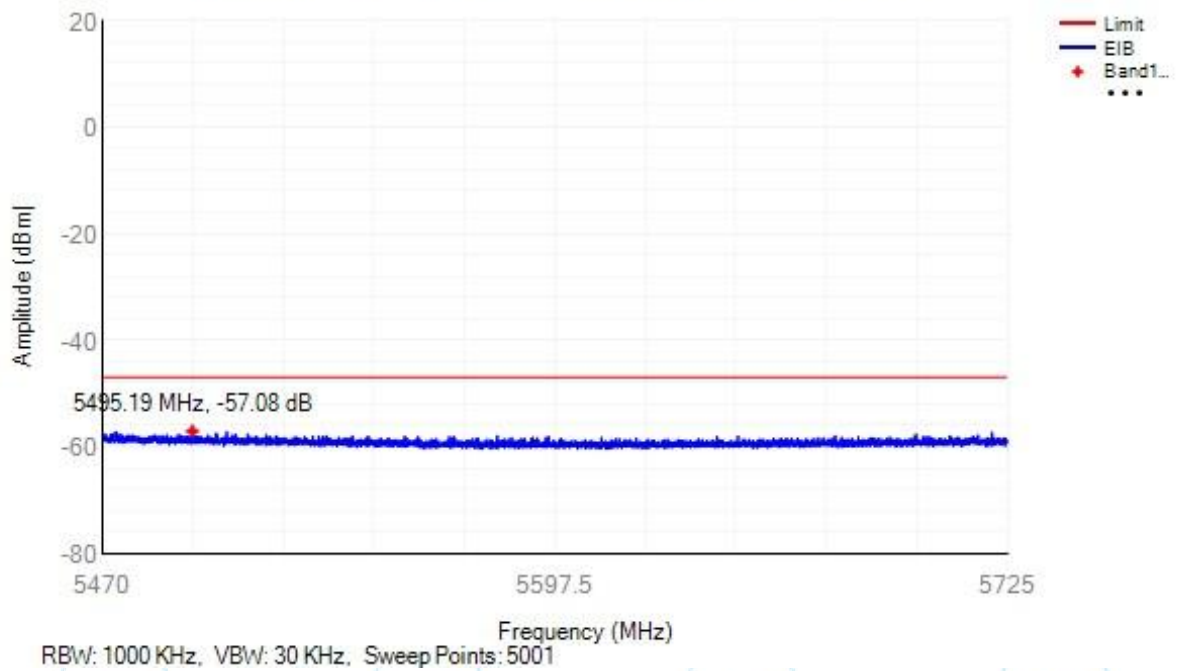

Frequency: 5200.00 MHz
Transmitter unwanted emissions within the 5 GHz RLAN bands

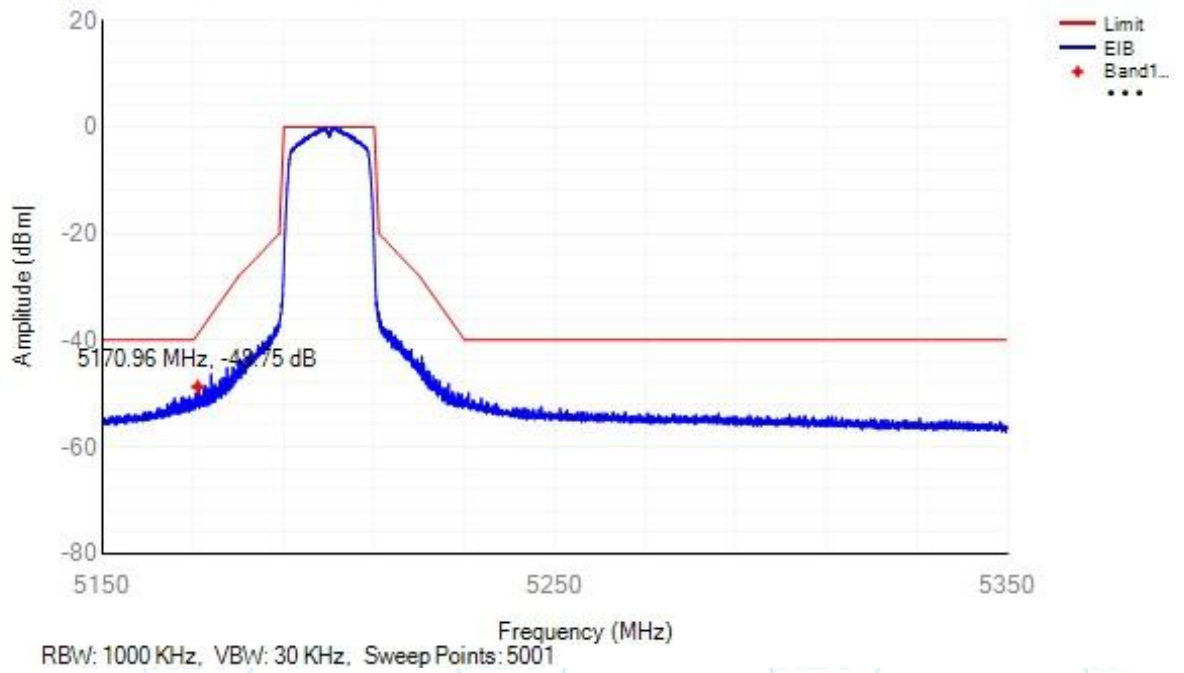

Tx. Emissions EIB NVNT ac20 5200MHz Sub Band2

Frequency: 5200.00 MHz
Transmitter unwanted emissions within the 5 GHz RLAN bands

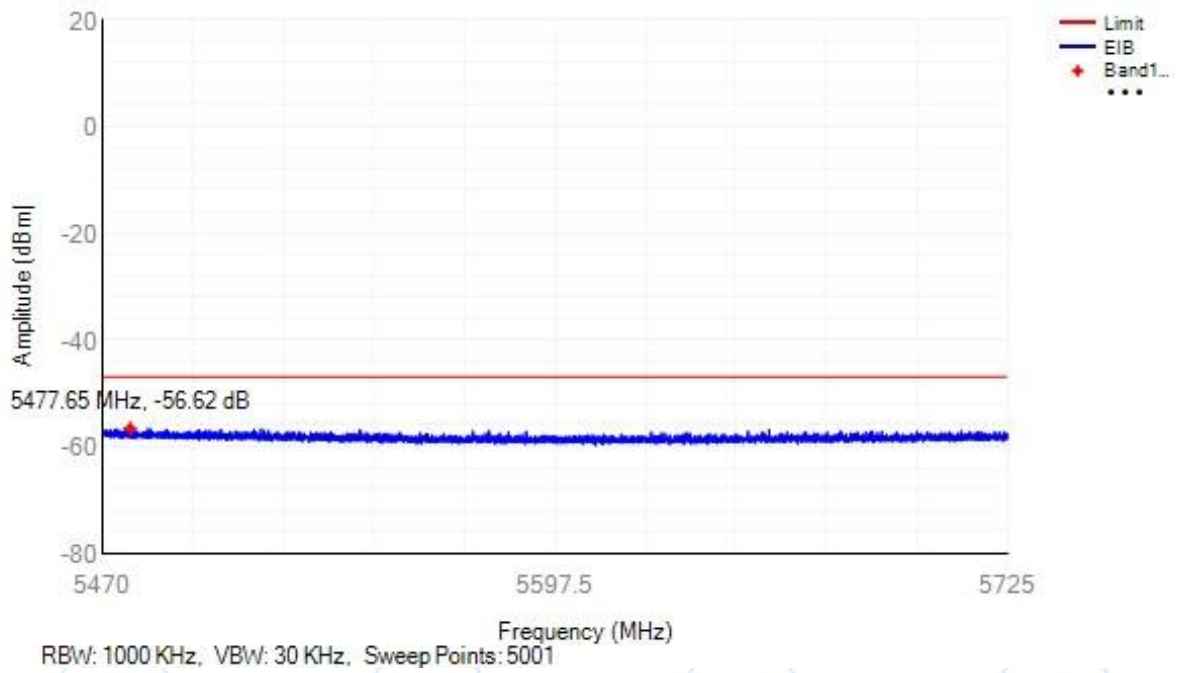

Frequency: 5249.00 MHz

Transmitter unwanted emissions within the 5 GHz RLAN bands

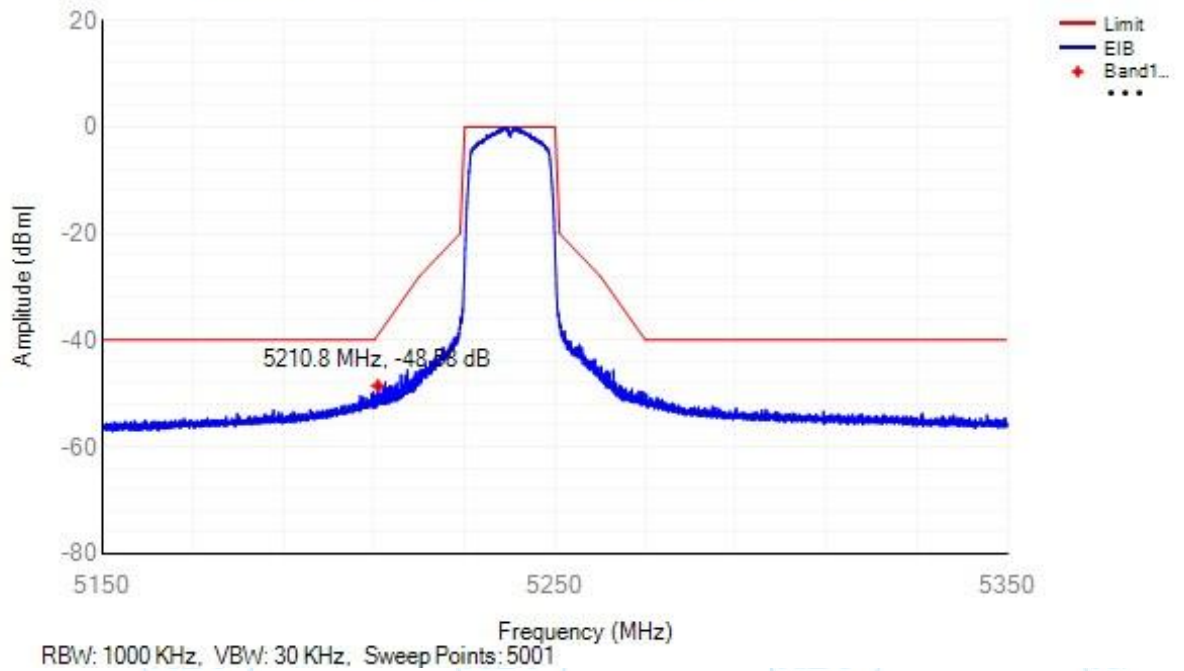

Tx. Emissions EIB NVNT ac20 5240MHz Sub Band2

Frequency: 5249.00 MHz

Transmitter unwanted emissions within the 5 GHz RLAN bands

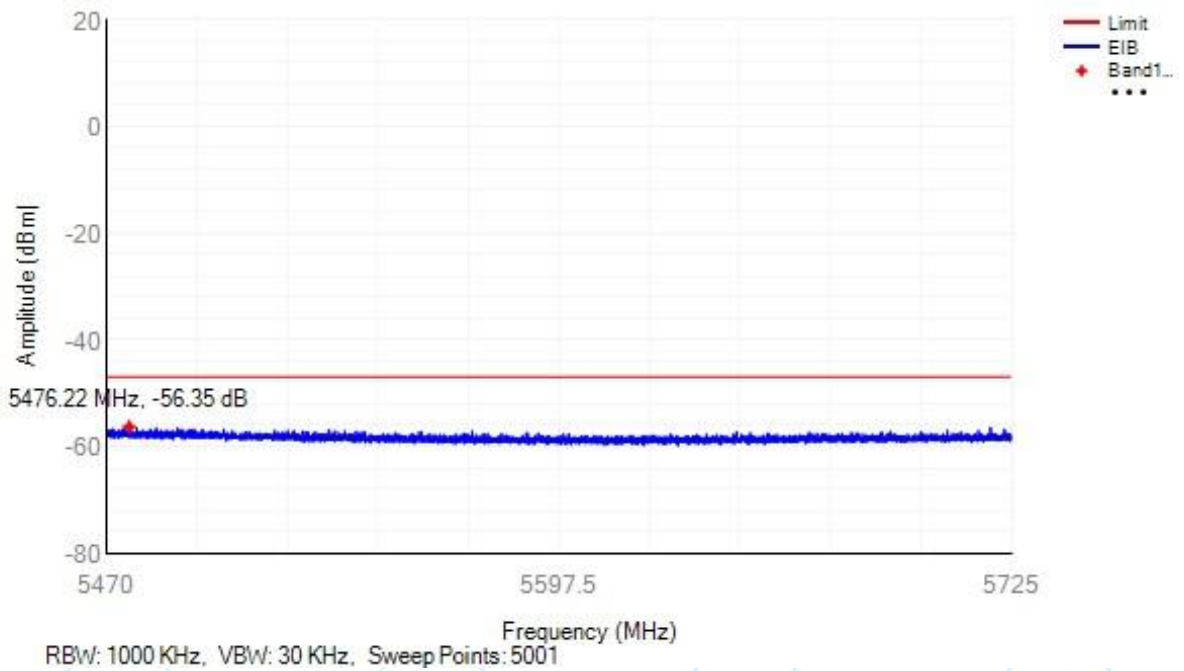

Frequency: 5190.00 MHz

Transmitter unwanted emissions within the 5 GHz RLAN bands

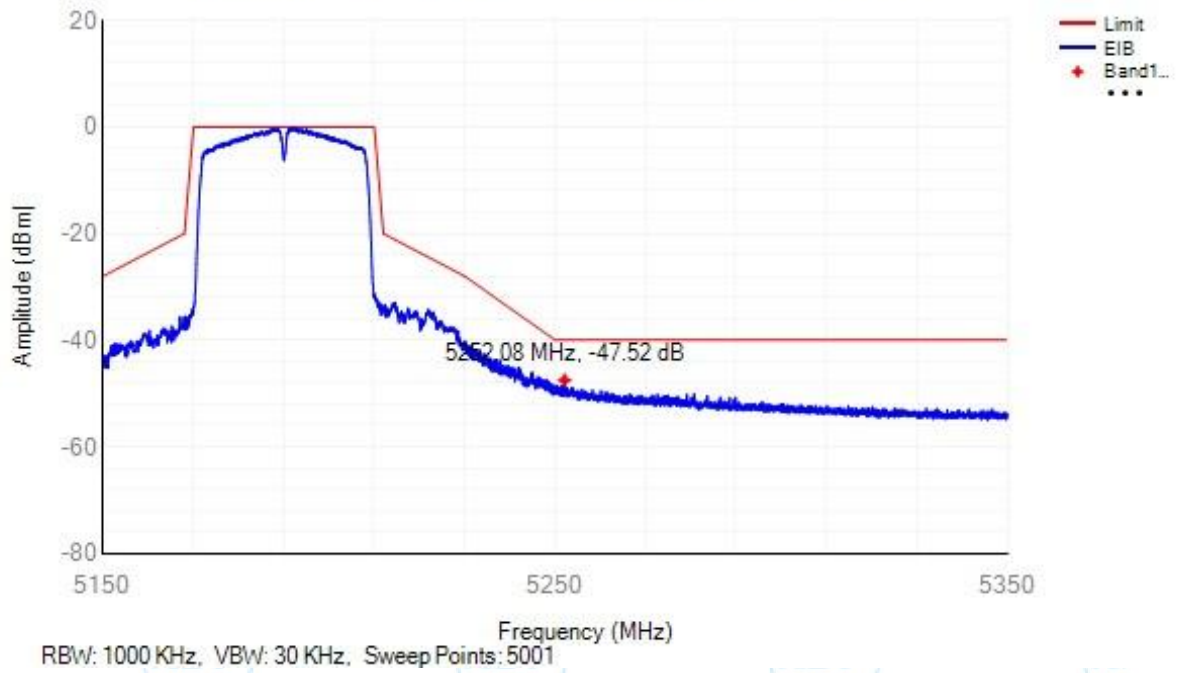

Tx. Emissions EIB NVNT ac40 5190MHz Sub Band2

Frequency: 5190.00 MHz

Transmitter unwanted emissions within the 5 GHz RLAN bands

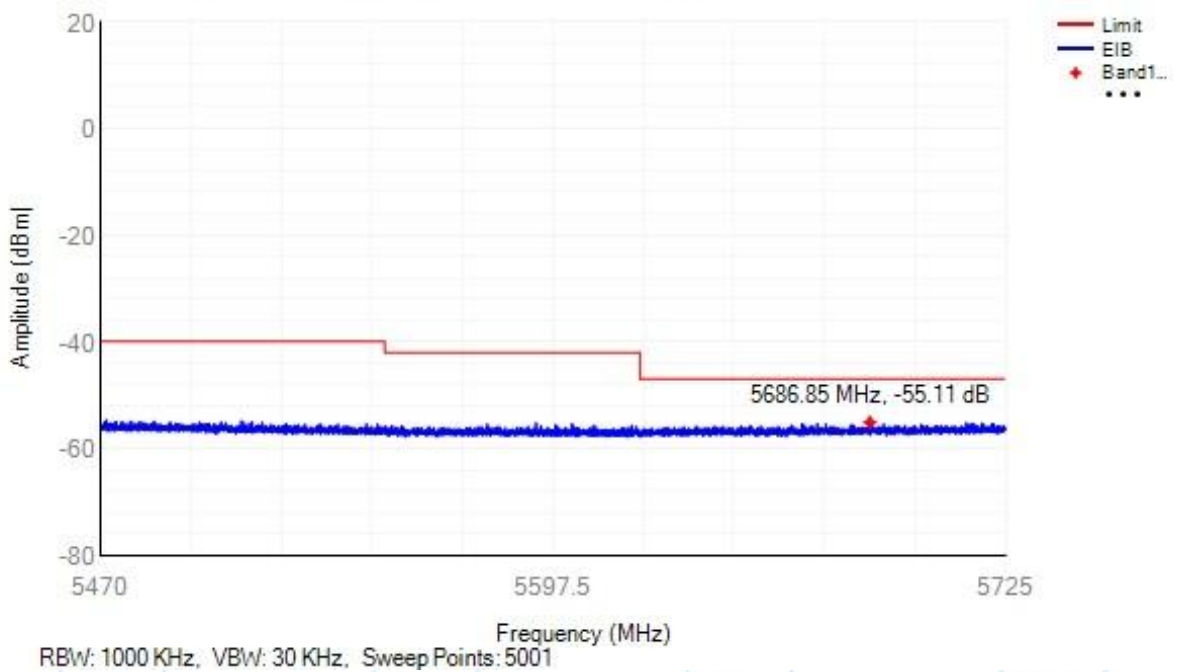

Frequency: 5239.00 MHz

Transmitter unwanted emissions within the 5 GHz RLAN bands

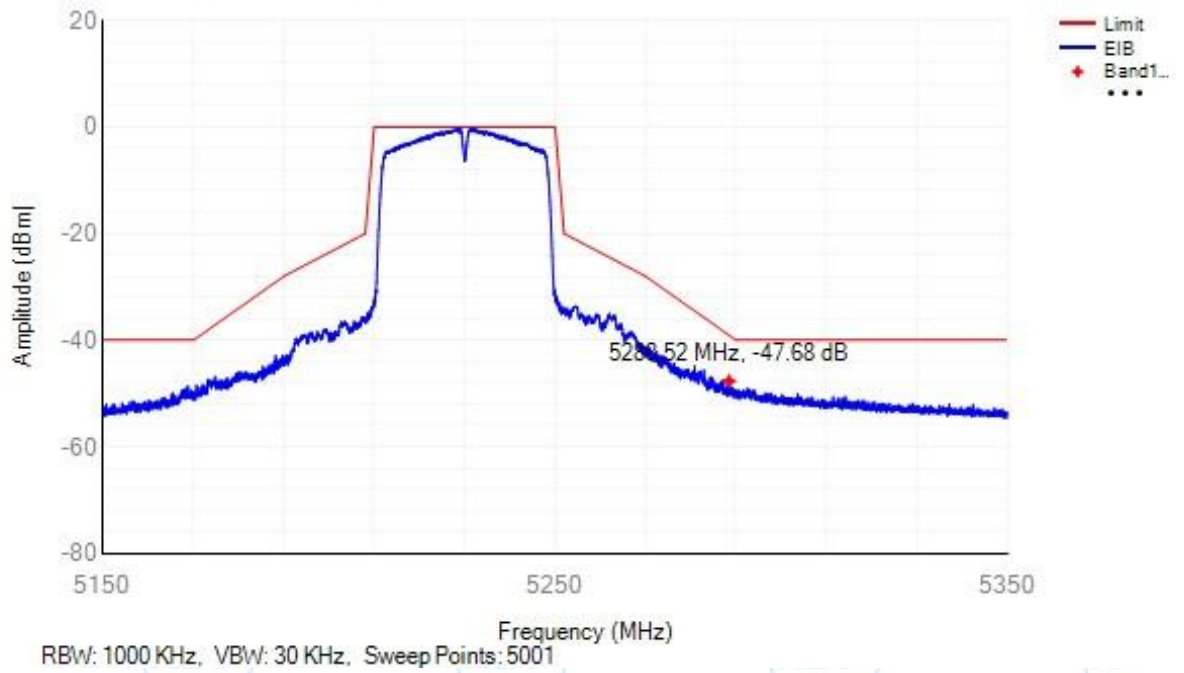

Tx. Emissions EIB NVNT ac40 5230MHz Sub Band2

Frequency: 5239.00 MHz

Transmitter unwanted emissions within the 5 GHz RLAN bands



Frequency: 5219.00 MHz

Transmitter unwanted emissions within the 5 GHz RLAN bands

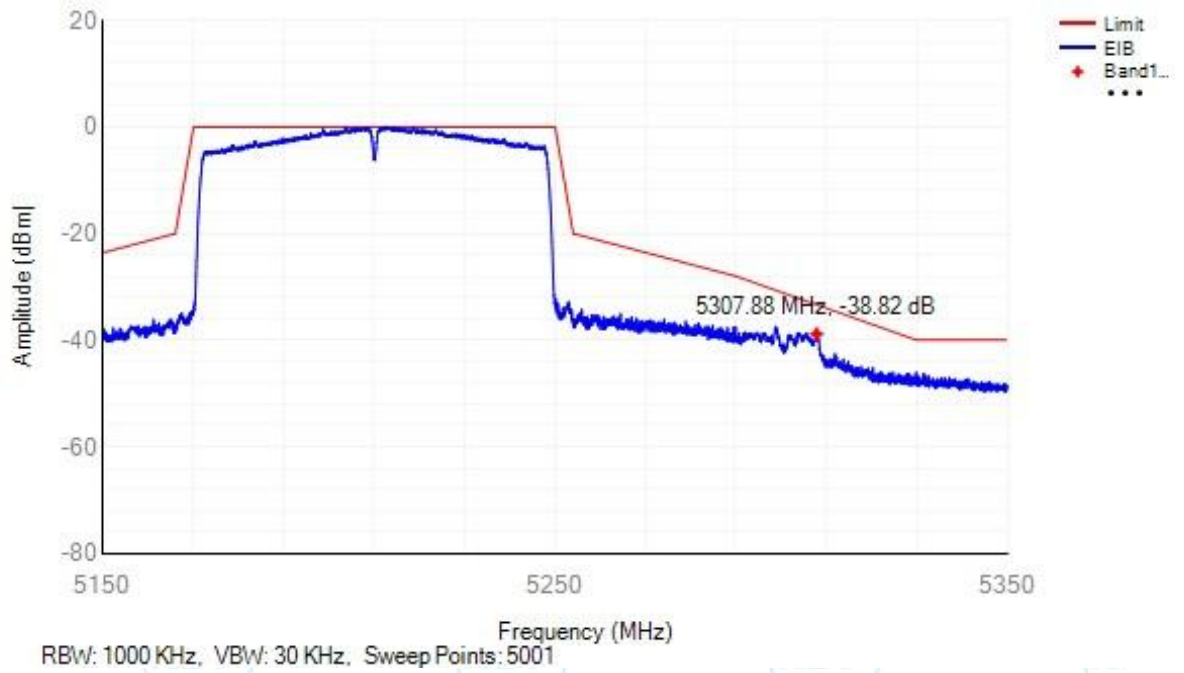

Tx. Emissions EIB NVNT ac80 5210MHz Sub Band2

Frequency: 5219.00 MHz

Transmitter unwanted emissions within the 5 GHz RLAN bands

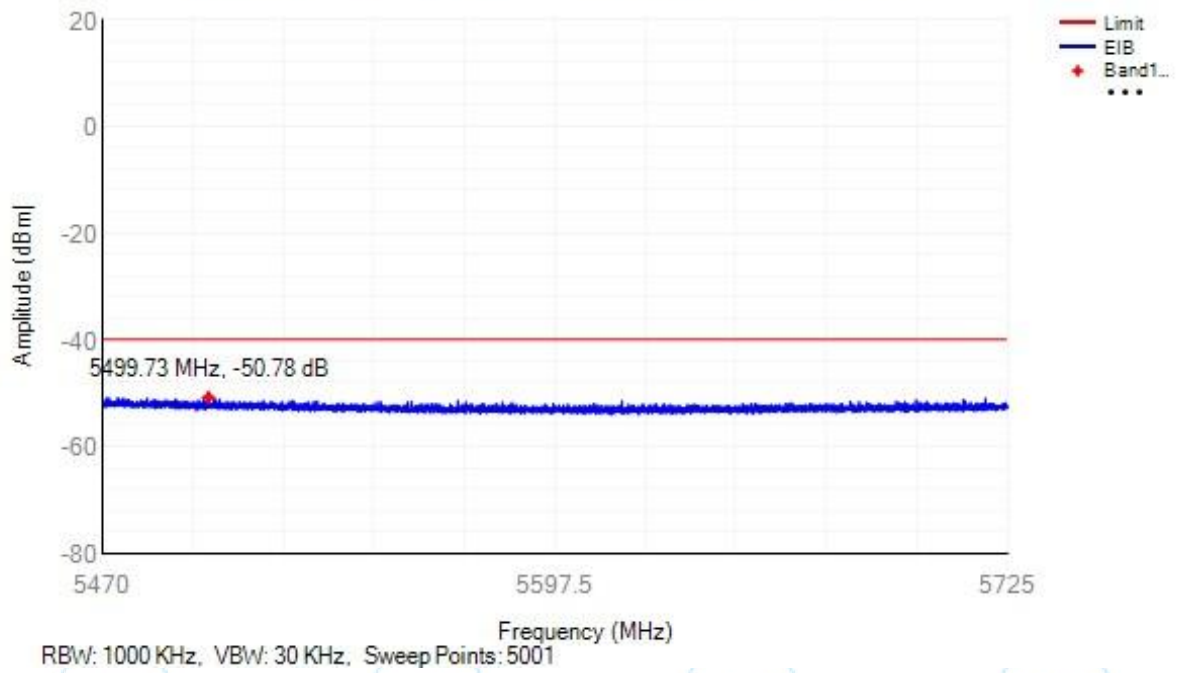

Frequency: 5180.00 MHz

Transmitter unwanted emissions within the 5 GHz RLAN bands

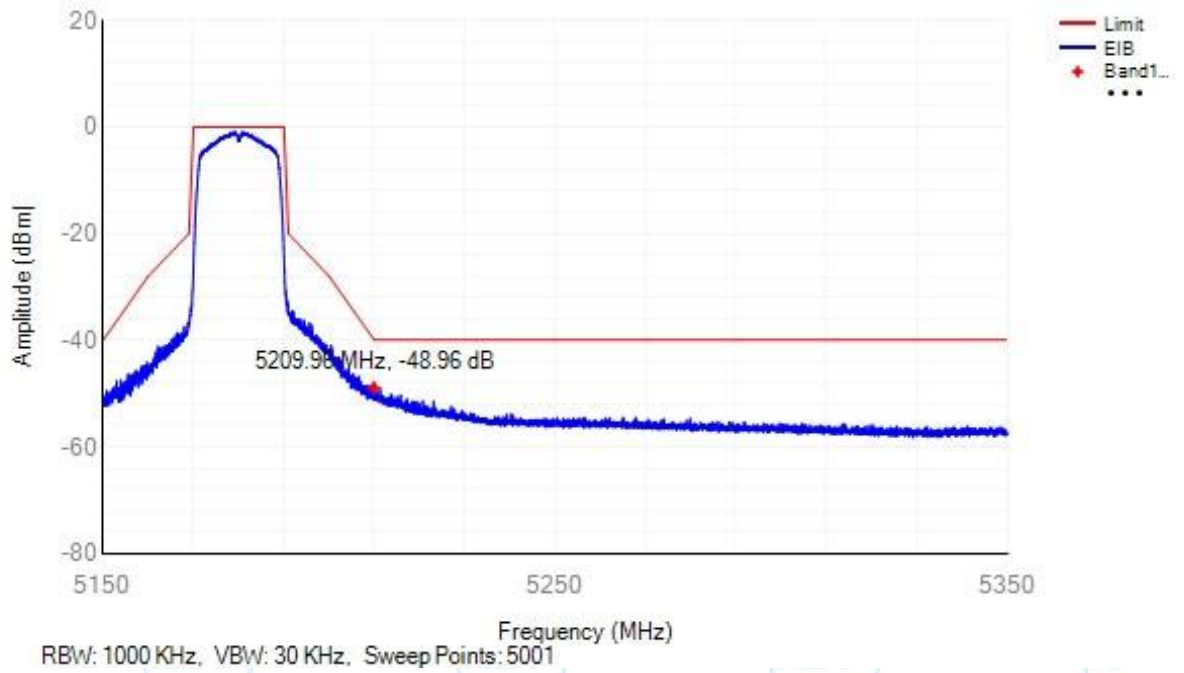

Tx. Emissions EIB NVNT n20 5180MHz Sub Band2

Frequency: 5180.00 MHz

Transmitter unwanted emissions within the 5 GHz RLAN bands

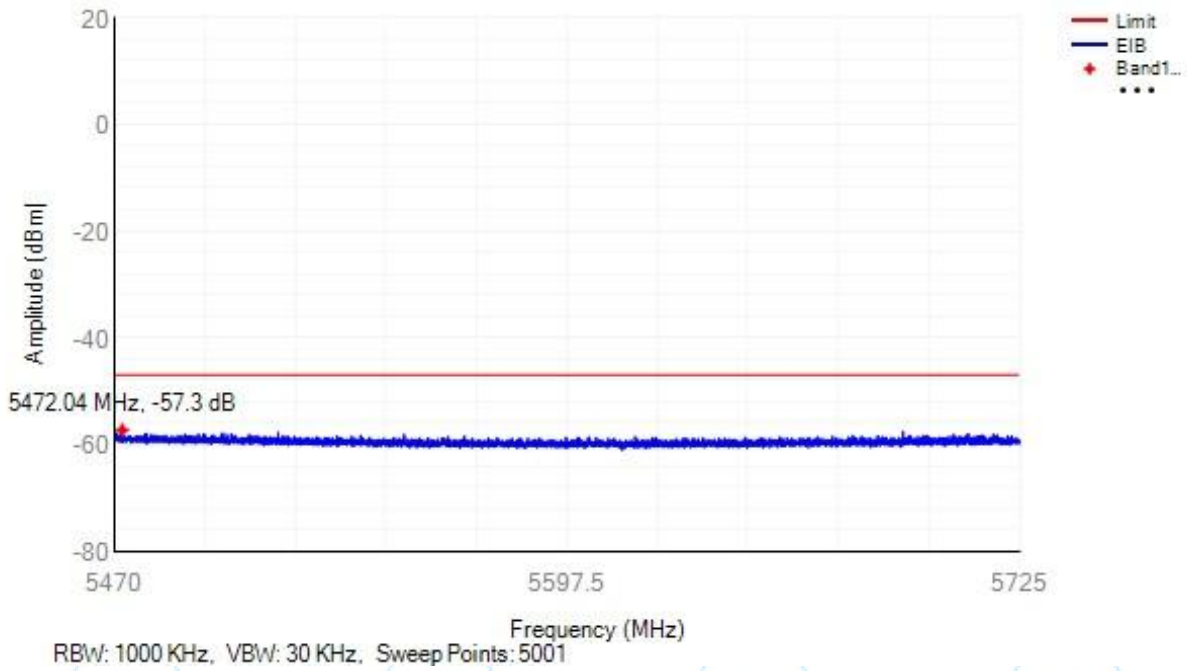

Frequency: 5200.00 MHz

Transmitter unwanted emissions within the 5 GHz RLAN bands

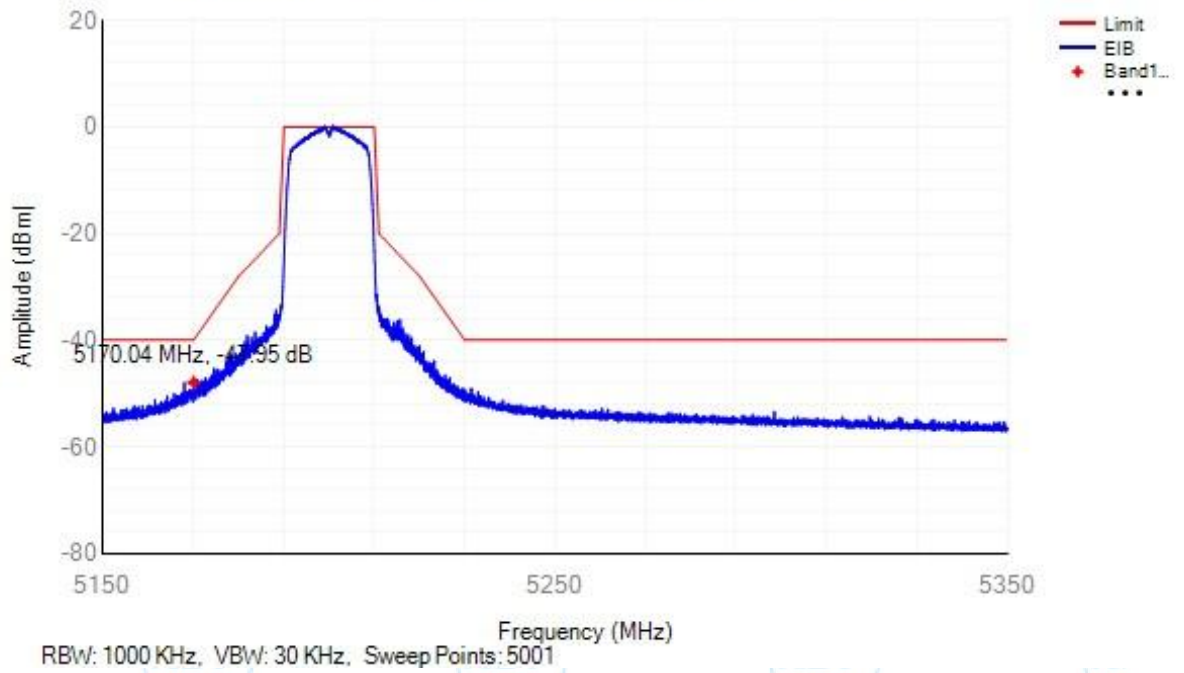

Tx. Emissions EIB NVNT n20 5200MHz Sub Band2

Frequency: 5200.00 MHz

Transmitter unwanted emissions within the 5 GHz RLAN bands

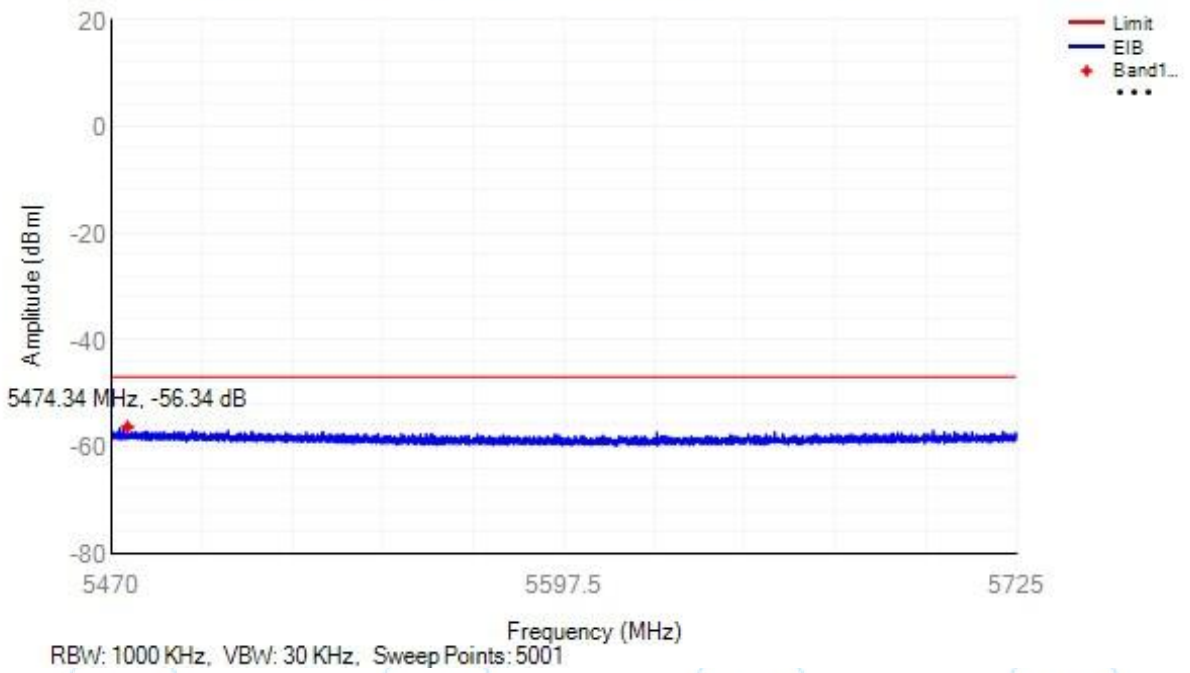

Frequency: 5249.00 MHz

Transmitter unwanted emissions within the 5 GHz RLAN bands

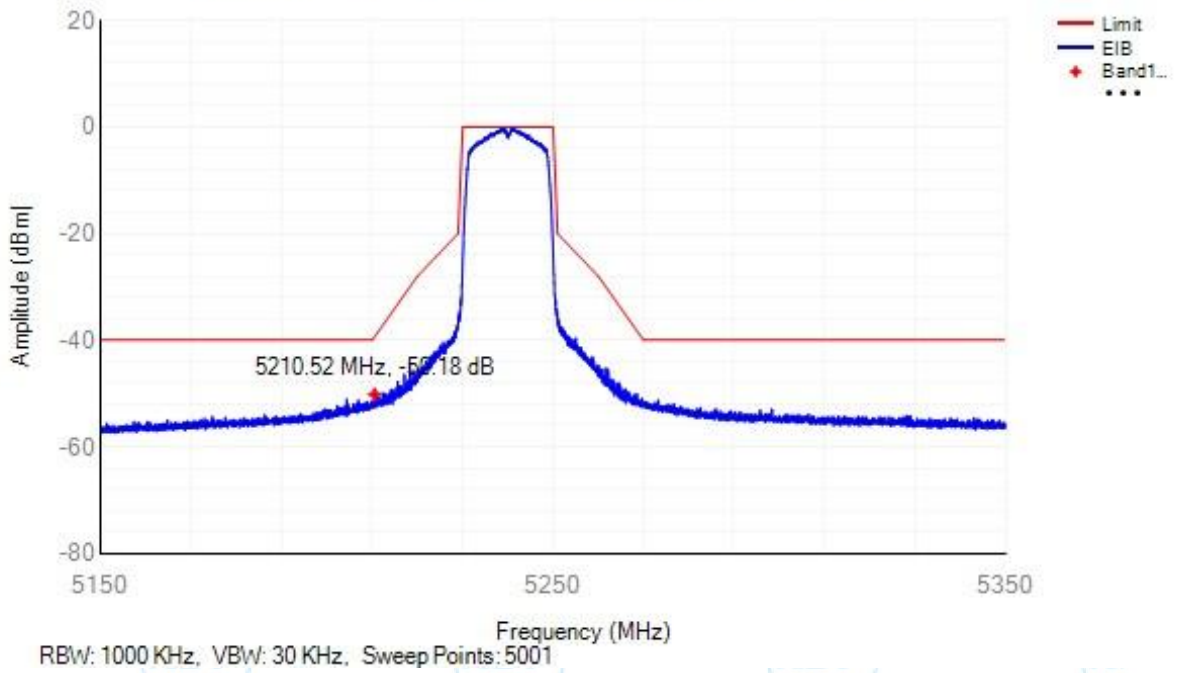

Tx. Emissions EIB NVNT n20 5240MHz Sub Band2

Frequency: 5249.00 MHz

Transmitter unwanted emissions within the 5 GHz RLAN bands

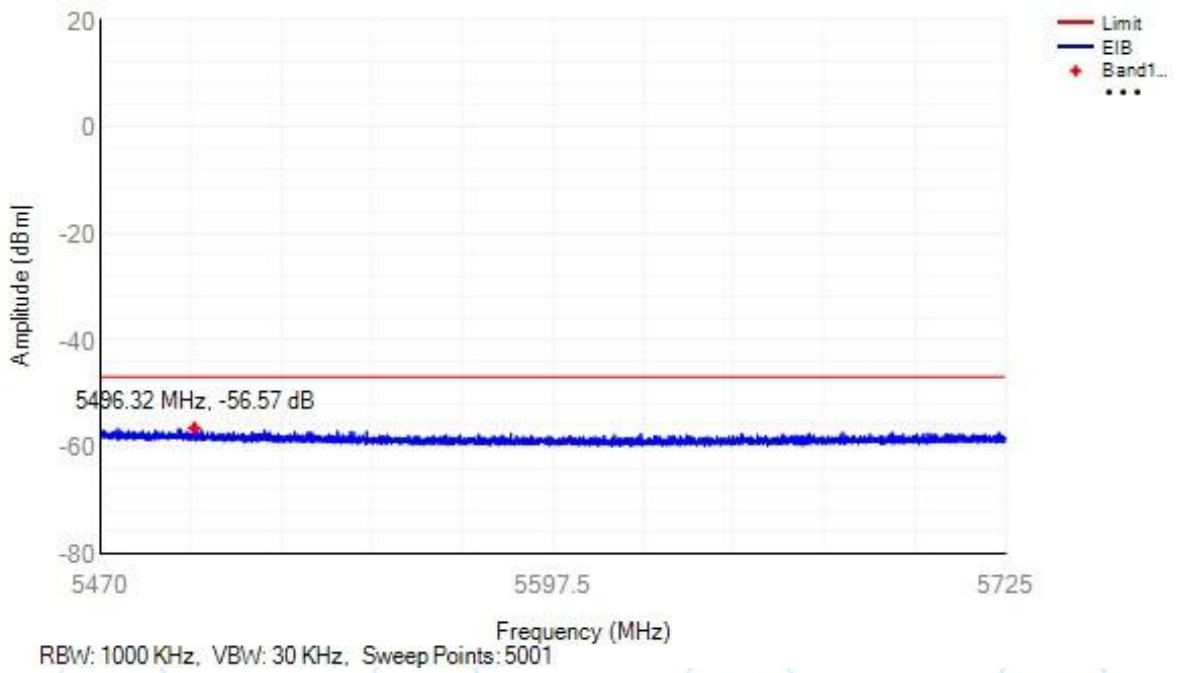

Frequency: 5190.00 MHz

Transmitter unwanted emissions within the 5 GHz RLAN bands

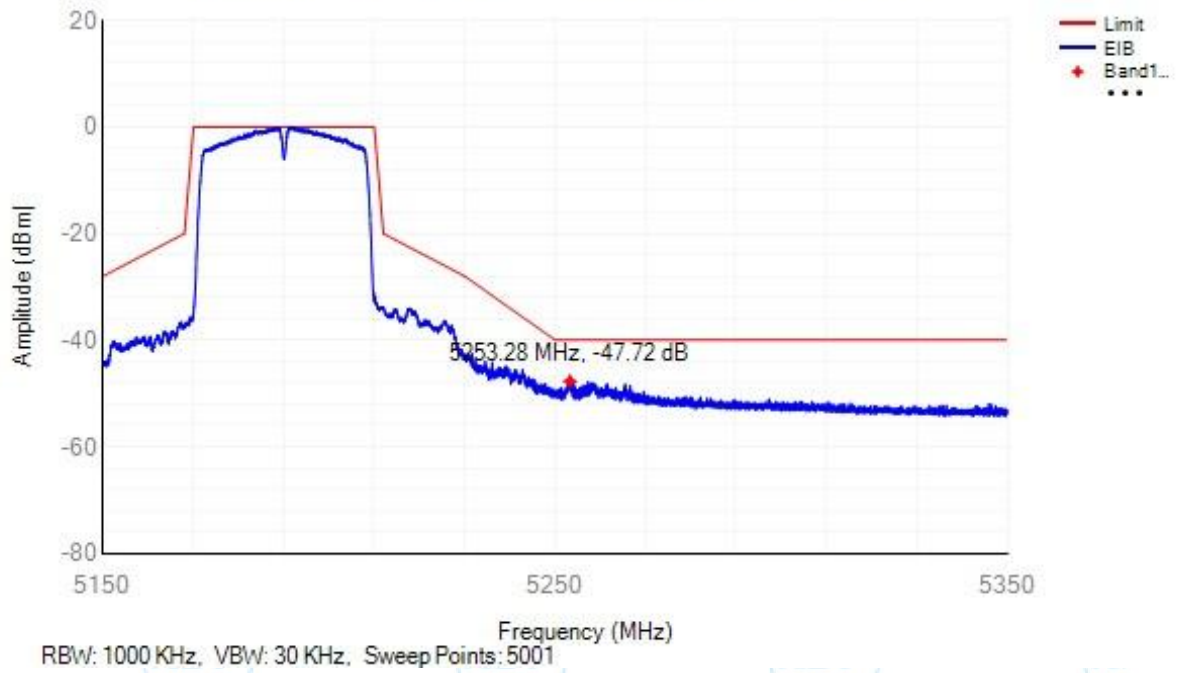

Tx. Emissions EIB NVNT n40 5190MHz Sub Band2

Frequency: 5190.00 MHz

Transmitter unwanted emissions within the 5 GHz RLAN bands

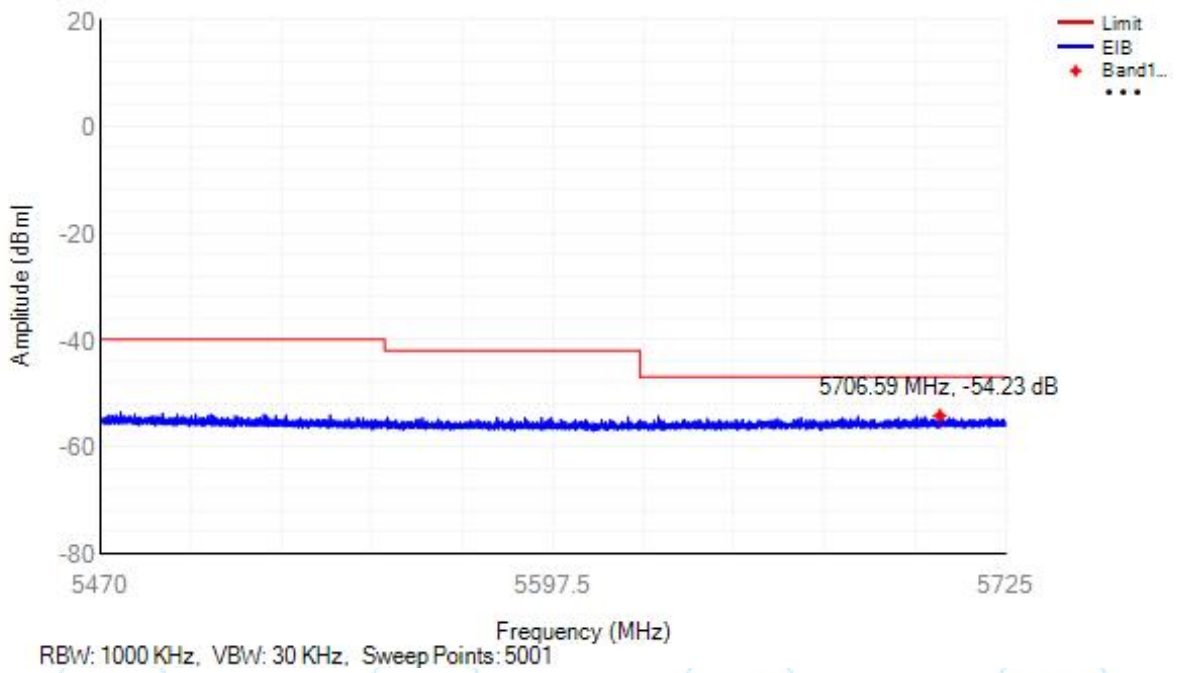

Frequency: 5230.00 MHz

Transmitter unwanted emissions within the 5 GHz RLAN bands

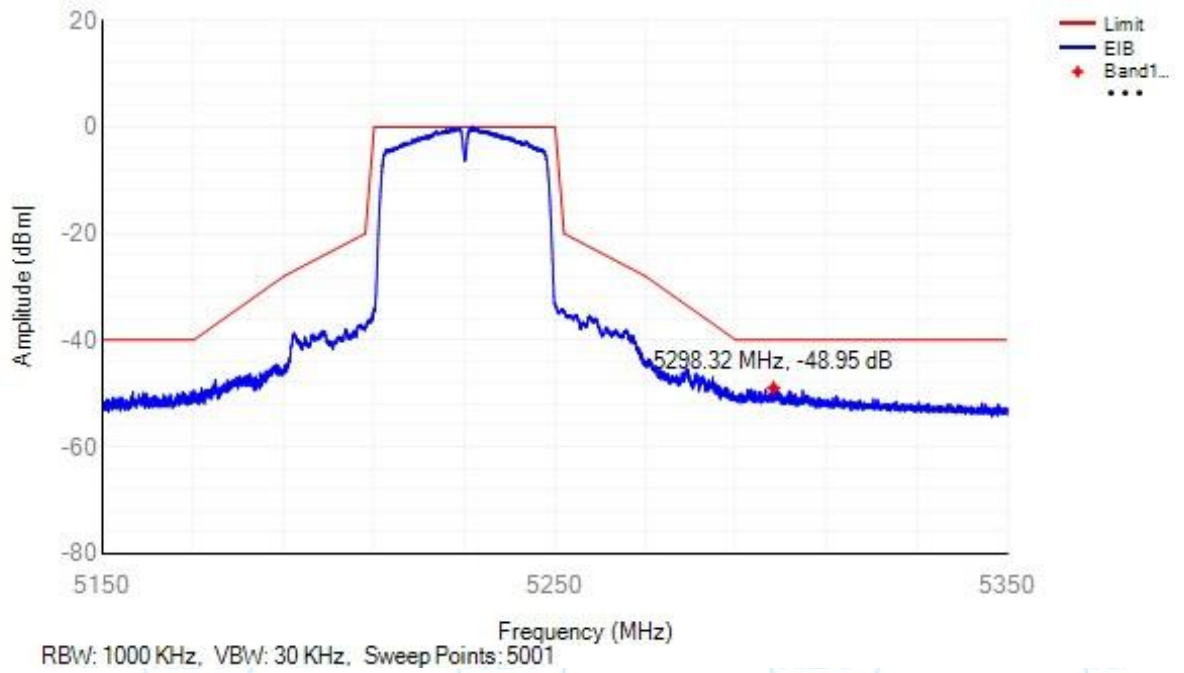

Tx. Emissions EIB NVNT n40 5230MHz Sub Band2

Frequency: 5230.00 MHz

Transmitter unwanted emissions within the 5 GHz RLAN bands

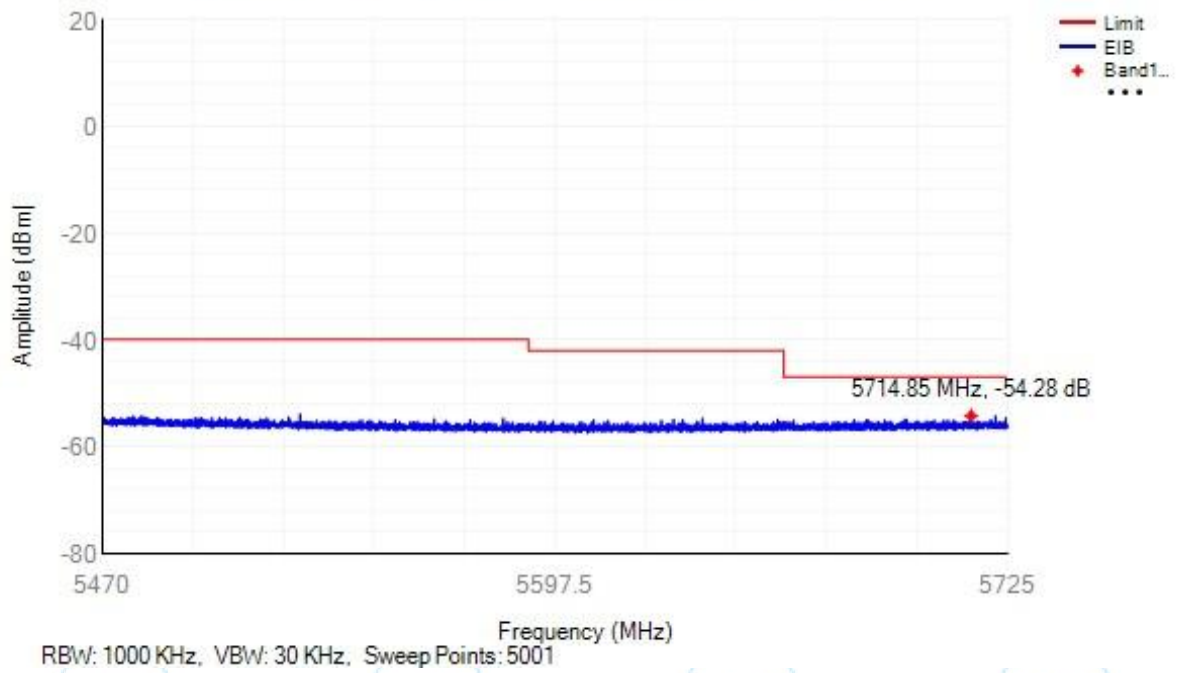

Condition	Mode	Frequency (MHz)	Antenna	Sub Band	Worst EIB Frequency (MHz)	Level (dB)	Limit (dB)	Verdict
NVNT	a	5260	Ant1	Band1	5291.72	-51.81	-40	Pass
NVNT	a	5260	Ant1	Band2	5525.95	-54.49	-47	Pass
NVNT	a	5280	Ant1	Band1	5312.16	-51.73	-40	Pass
NVNT	a	5280	Ant1	Band2	5499.73	-54.79	-47	Pass
NVNT	a	5320	Ant1	Band1	5279.4	-52.57	-40	Pass
NVNT	a	5320	Ant1	Band2	5570.57	-57.51	-47	Pass
NVNT	ac20	5260	Ant1	Band1	5289.88	-50.38	-39.85	Pass
NVNT	ac20	5260	Ant1	Band2	5492.44	-53.38	-47	Pass
NVNT	ac20	5280	Ant1	Band1	5314.04	-50.98	-40	Pass
NVNT	ac20	5280	Ant1	Band2	5501.77	-54.06	-47	Pass
NVNT	ac20	5320	Ant1	Band1	5289.28	-51.39	-40	Pass
NVNT	ac20	5320	Ant1	Band2	5537.88	-54.7	-47	Pass
NVNT	ac40	5270	Ant1	Band1	5332.52	-48.68	-40	Pass
NVNT	ac40	5270	Ant1	Band2	5703.68	-51.62	-47	Pass
NVNT	ac40	5310	Ant1	Band1	5242.04	-49.23	-40	Pass
NVNT	ac40	5310	Ant1	Band2	5724.08	-52.07	-42	Pass
NVNT	ac80	5290	Ant1	Band1	5168.2	-47.17	-40	Pass
NVNT	ac80	5290	Ant1	Band2	5471.48	-47.36	-40	Pass
NVNT	n20	5260	Ant1	Band1	5229.96	-49.86	-40	Pass
NVNT	n20	5260	Ant1	Band2	5492.29	-56.65	-47	Pass
NVNT	n20	5280	Ant1	Band1	5311.16	-51.01	-40	Pass
NVNT	n20	5280	Ant1	Band2	5508.71	-54.07	-47	Pass
NVNT	n20	5320	Ant1	Band1	5285.12	-51.57	-40	Pass
NVNT	n20	5320	Ant1	Band2	5549.25	-54.66	-47	Pass
NVNT	n40	5270	Ant1	Band1	5332.6	-48	-40	Pass
NVNT	n40	5270	Ant1	Band2	5706.54	-51.1	-47	Pass
NVNT	n40	5310	Ant1	Band1	5229.04	-48.49	-40	Pass
NVNT	n40	5310	Ant1	Band2	5718.22	-51.03	-42	Pass

Frequency: 5260.00 MHz

Transmitter unwanted emissions within the 5 GHz RLAN bands

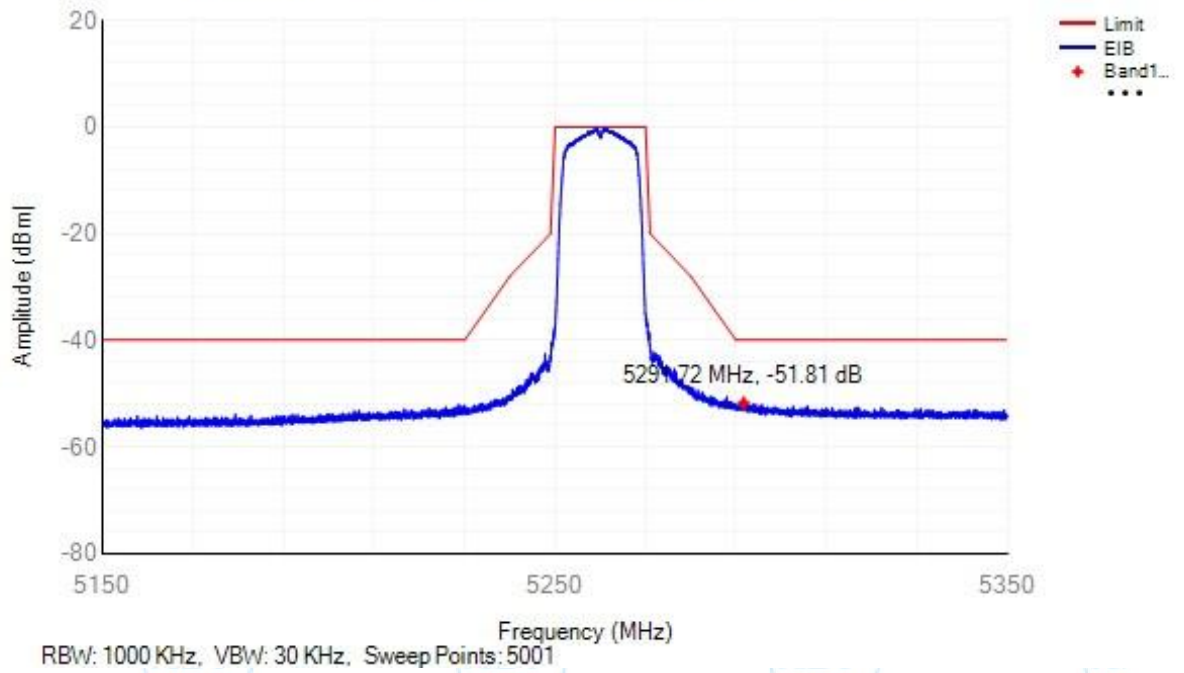

Tx. Emissions EIB NVNT a 5260MHz Sub Band2

Frequency: 5260.00 MHz

Transmitter unwanted emissions within the 5 GHz RLAN bands

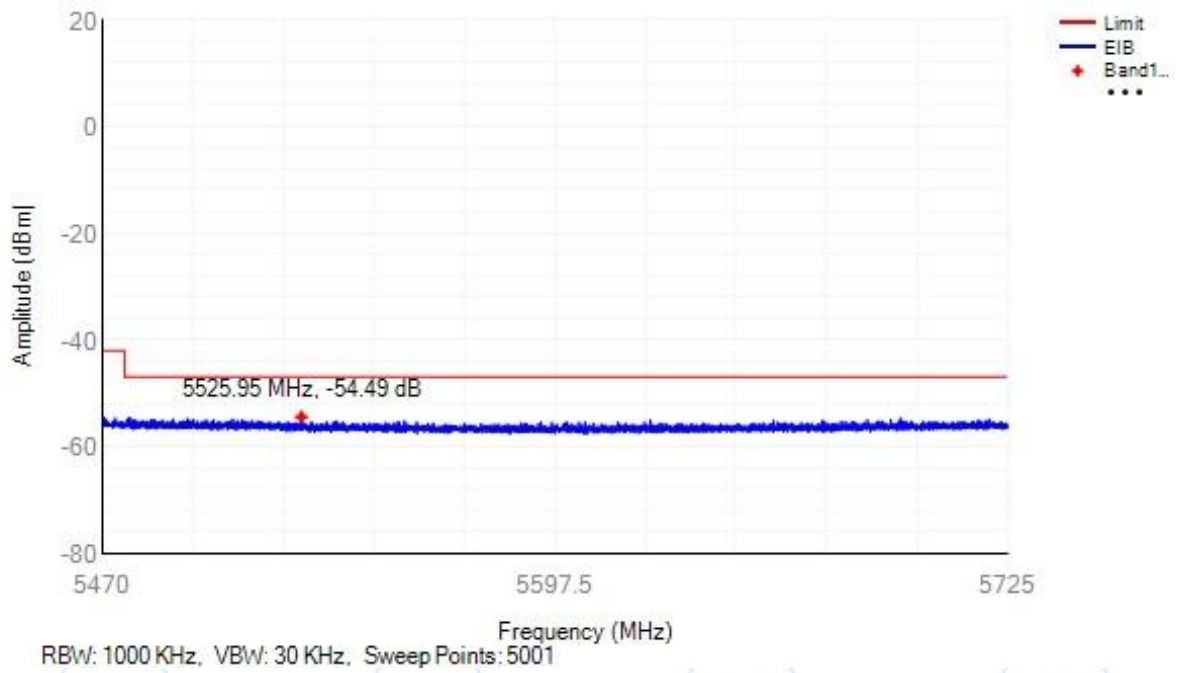

Frequency: 5280.00 MHz

Transmitter unwanted emissions within the 5 GHz RLAN bands

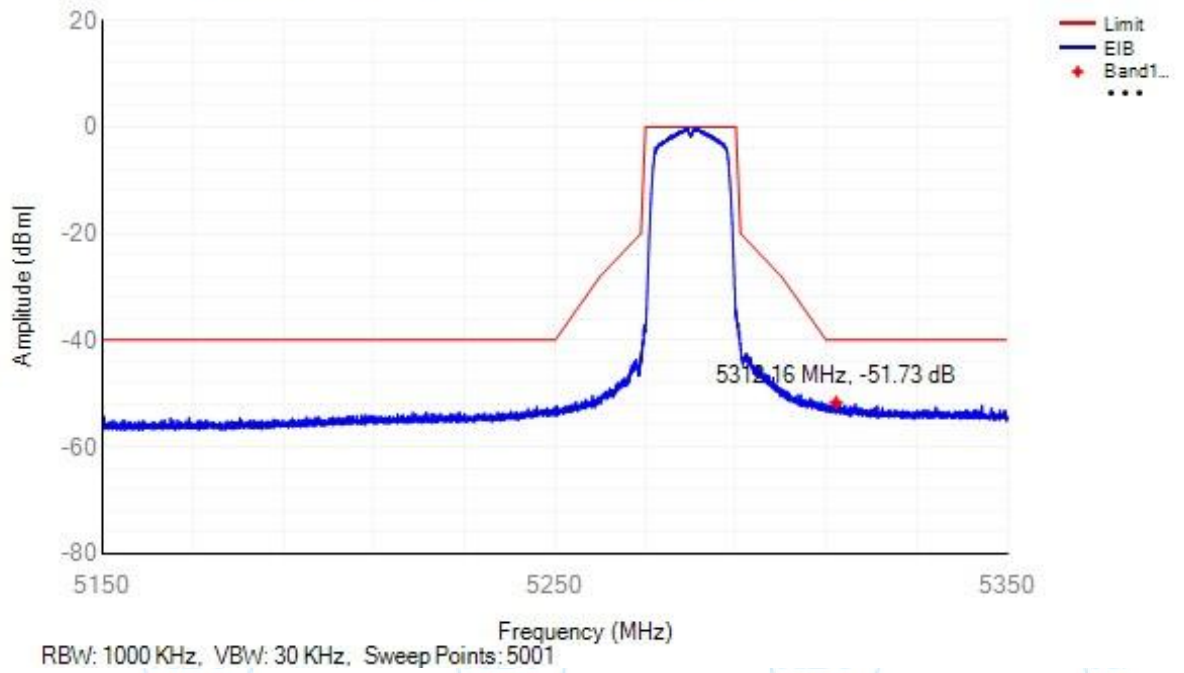

Tx. Emissions EIB NVNT a 5280MHz Sub Band2

Frequency: 5280.00 MHz

Transmitter unwanted emissions within the 5 GHz RLAN bands

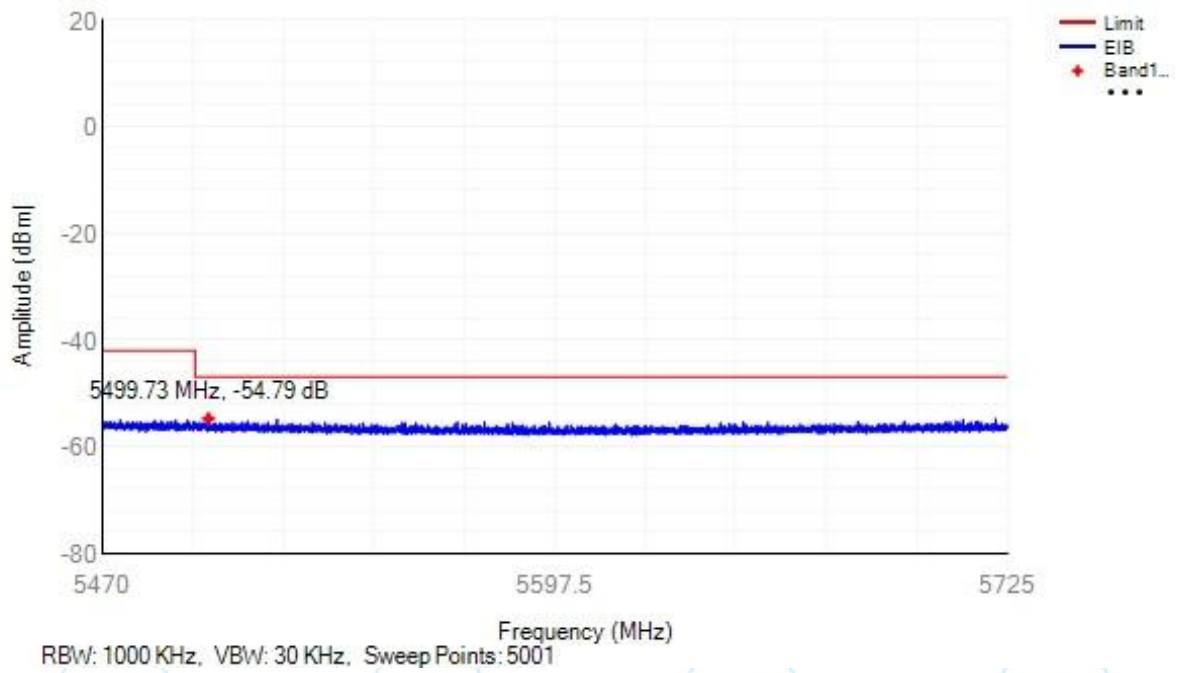

Frequency: 5329.00 MHz

Transmitter unwanted emissions within the 5 GHz RLAN bands

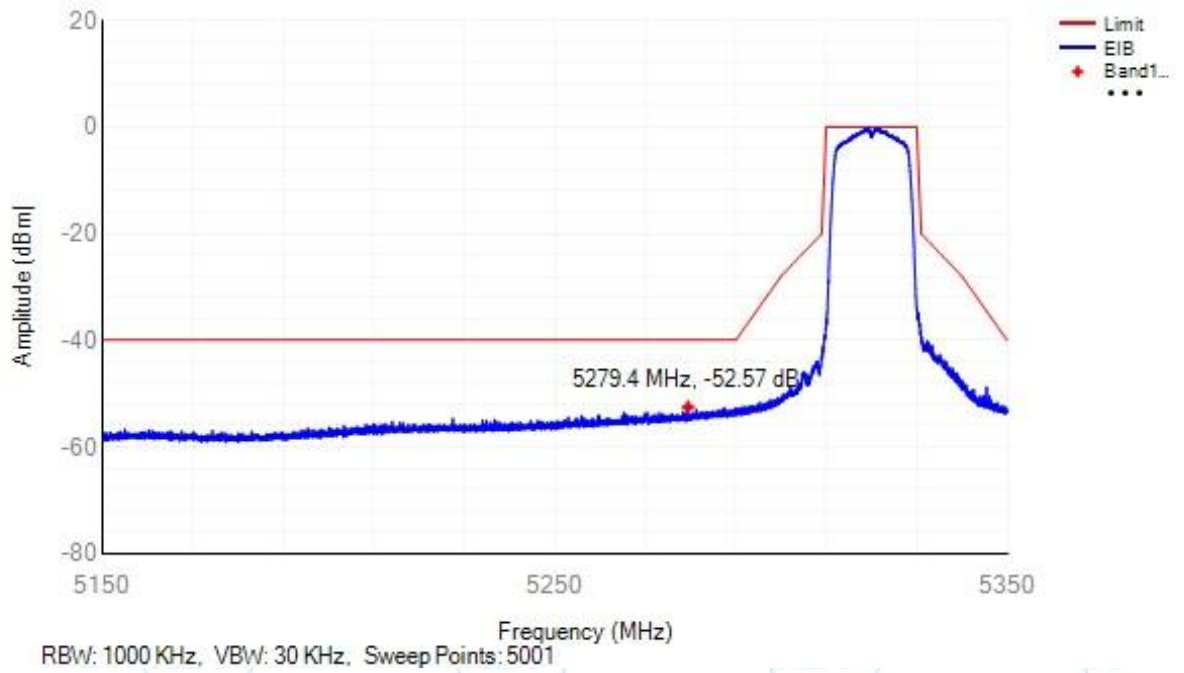

Tx. Emissions EIB NVNT a 5320MHz Sub Band2

Frequency: 5329.00 MHz

Transmitter unwanted emissions within the 5 GHz RLAN bands

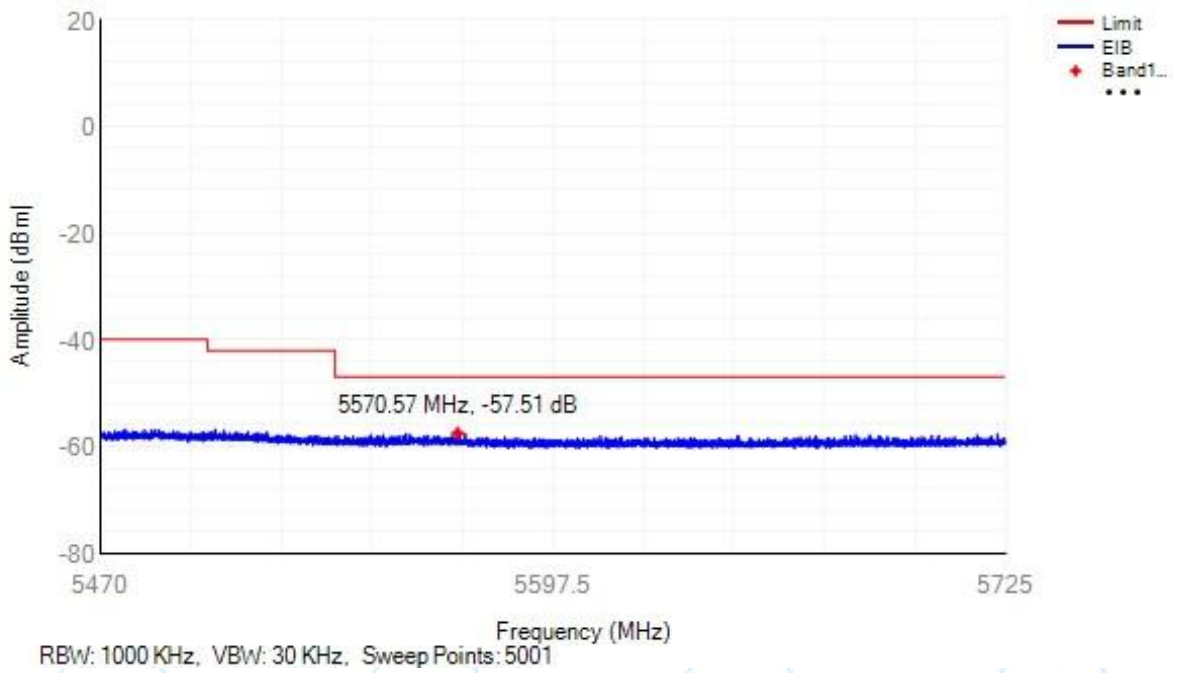

Frequency: 5269.00 MHz

Transmitter unwanted emissions within the 5 GHz RLAN bands

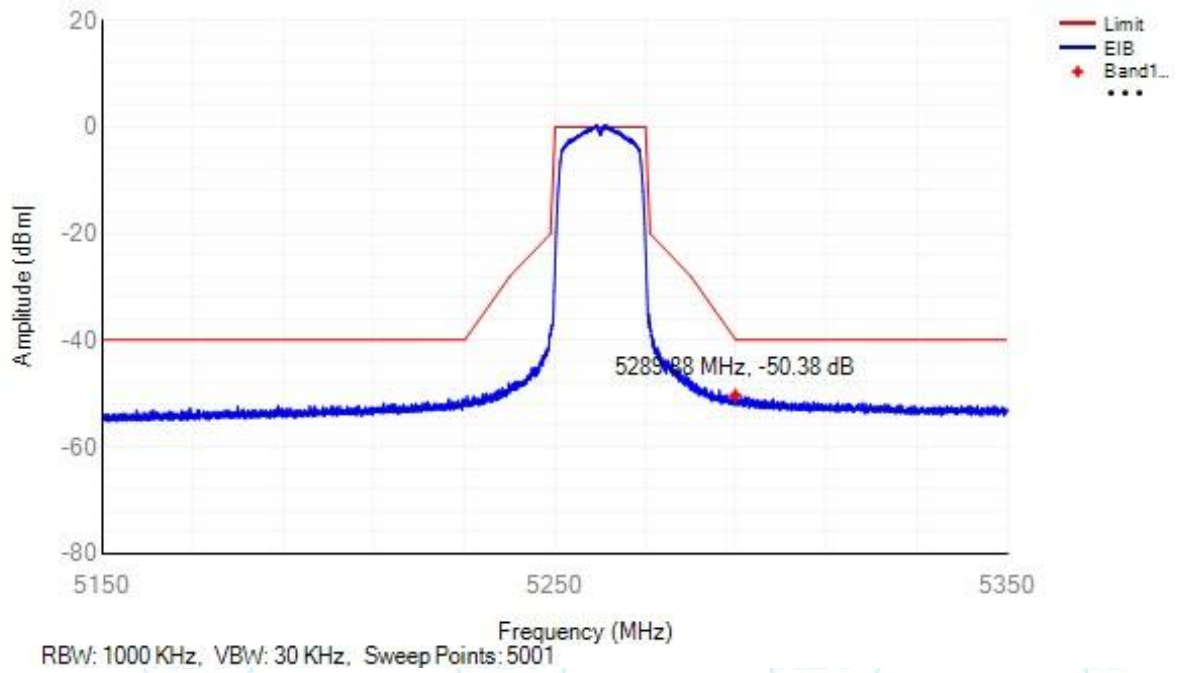

Tx. Emissions EIB NVNT ac20 5260MHz Sub Band2

Frequency: 5269.00 MHz

Transmitter unwanted emissions within the 5 GHz RLAN bands

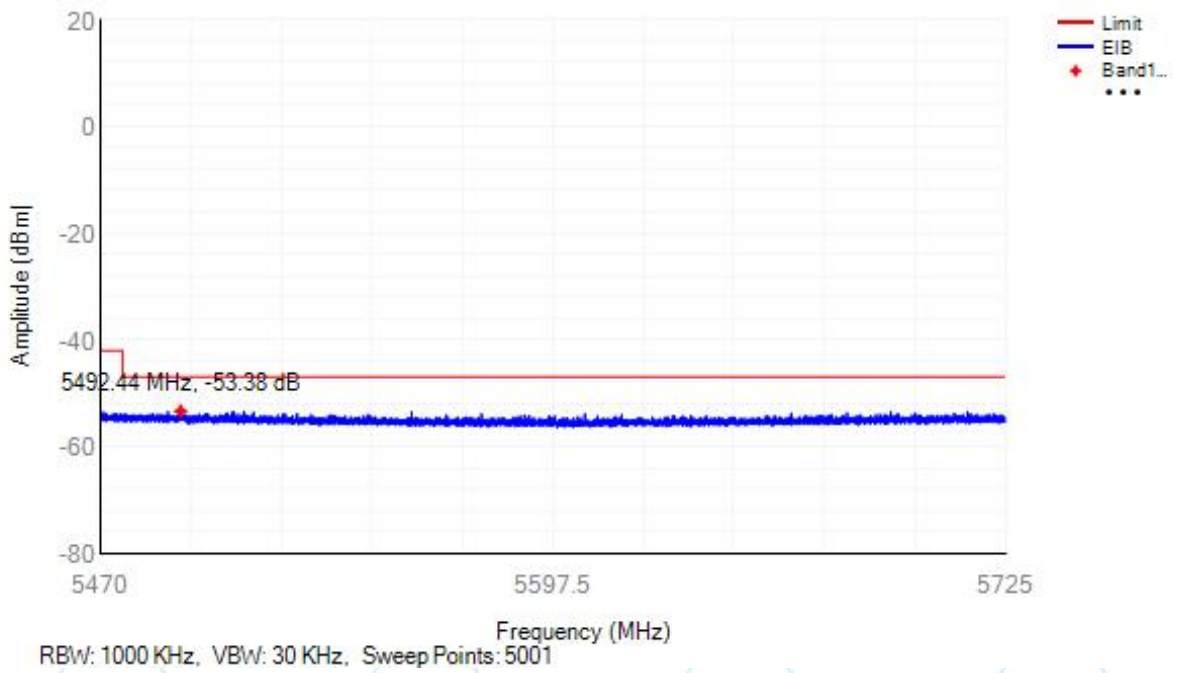

Frequency: 5280.00 MHz

Transmitter unwanted emissions within the 5 GHz RLAN bands

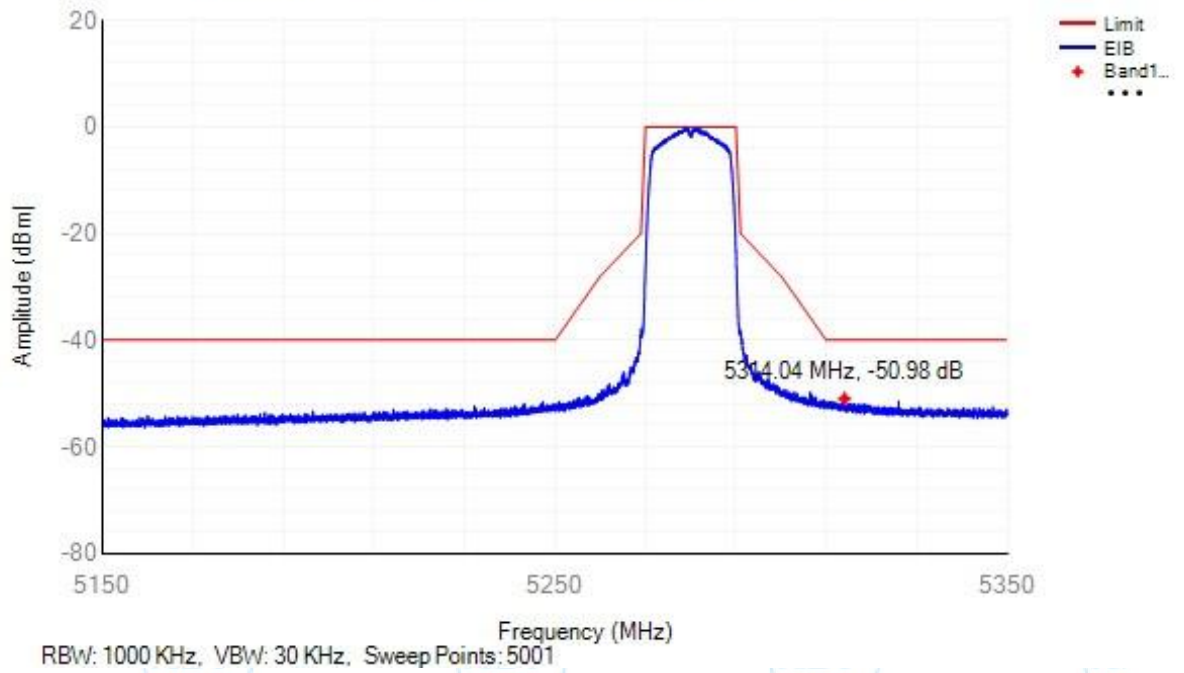

Tx. Emissions EIB NVNT ac20 5280MHz Sub Band2

Frequency: 5280.00 MHz

Transmitter unwanted emissions within the 5 GHz RLAN bands

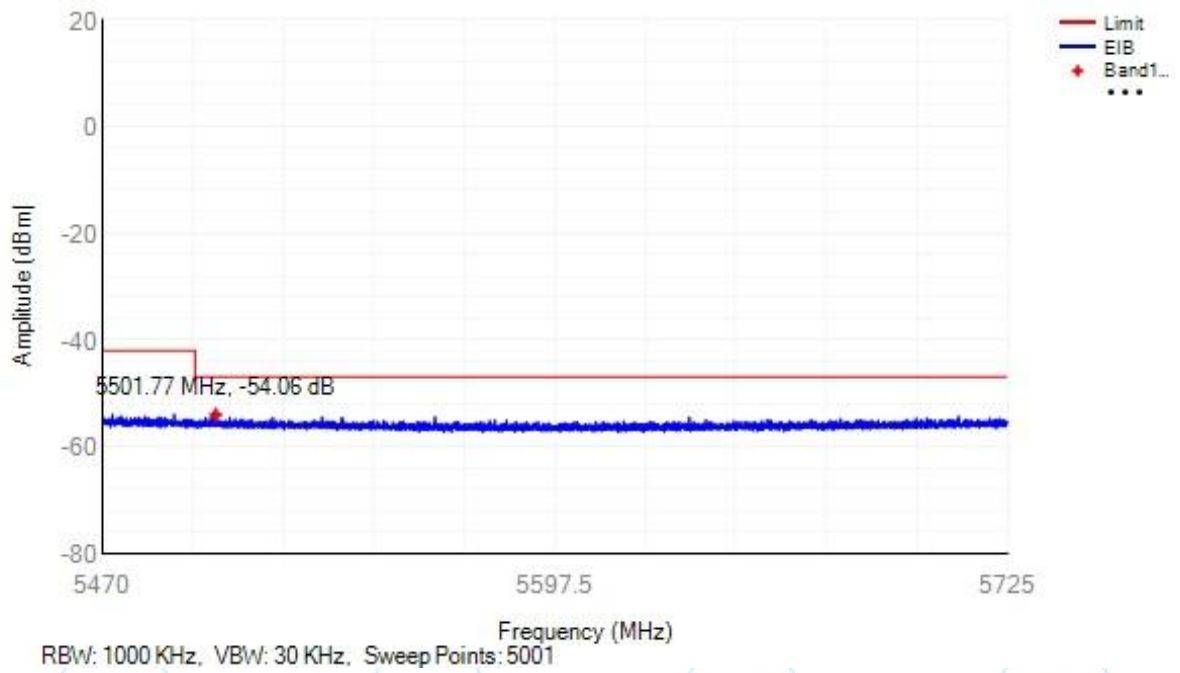

Frequency: 5329.00 MHz

Transmitter unwanted emissions within the 5 GHz WLAN bands

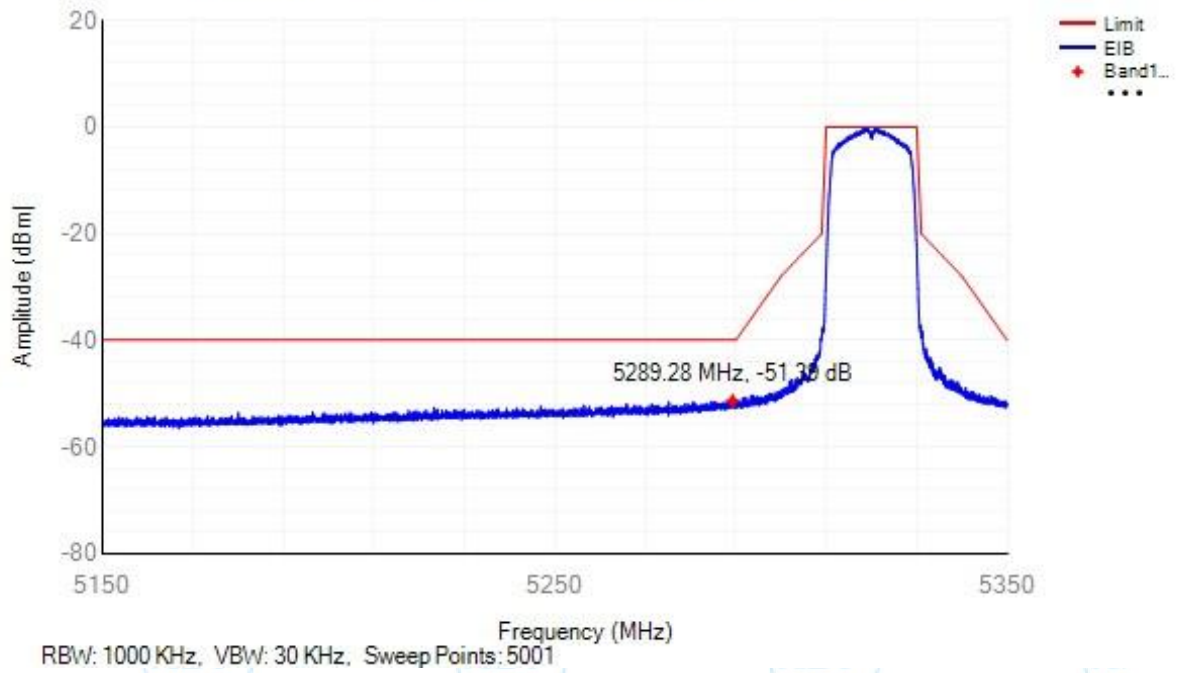

Tx. Emissions EIB NVNT ac20 5320MHz Sub Band2

Frequency: 5329.00 MHz

Transmitter unwanted emissions within the 5 GHz WLAN bands

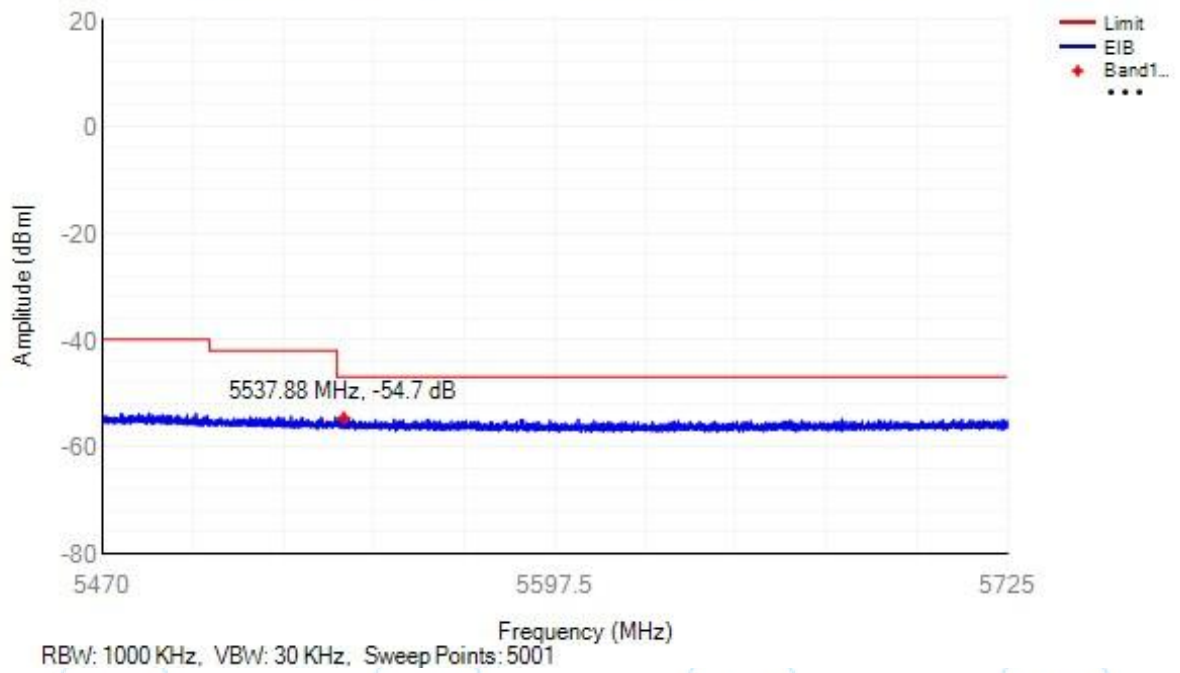

Frequency: 5279.00 MHz

Transmitter unwanted emissions within the 5 GHz RLAN bands

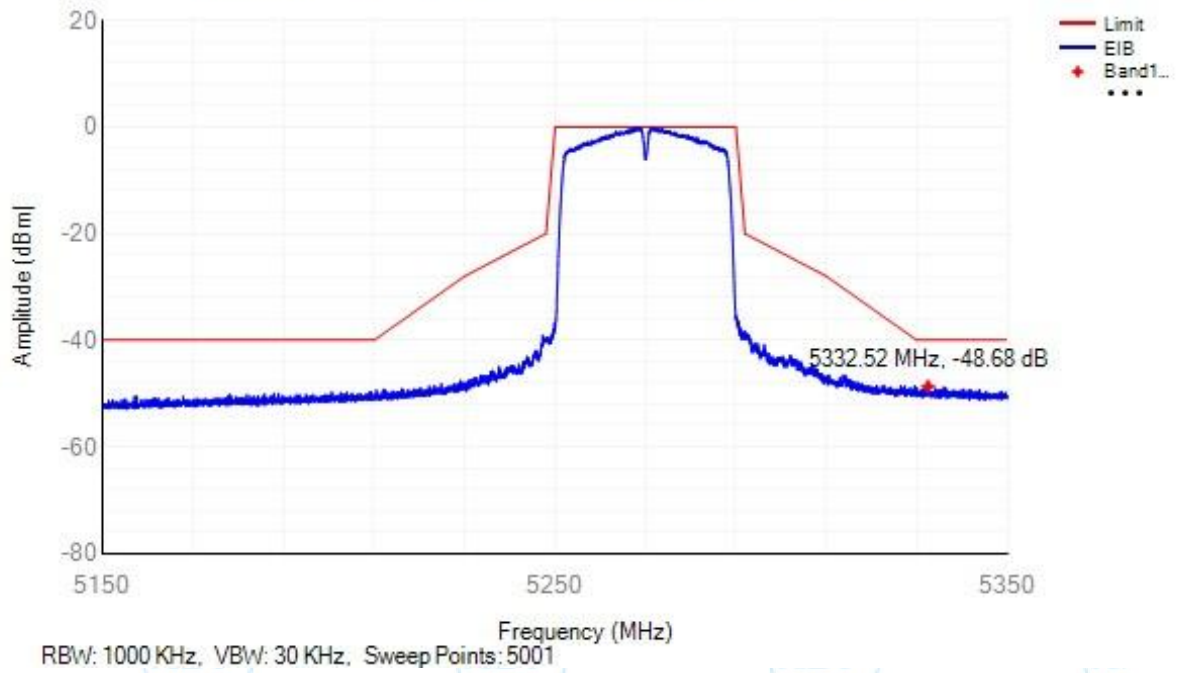

Tx. Emissions EIB NVNT ac40 5270MHz Sub Band2

Frequency: 5279.00 MHz

Transmitter unwanted emissions within the 5 GHz RLAN bands

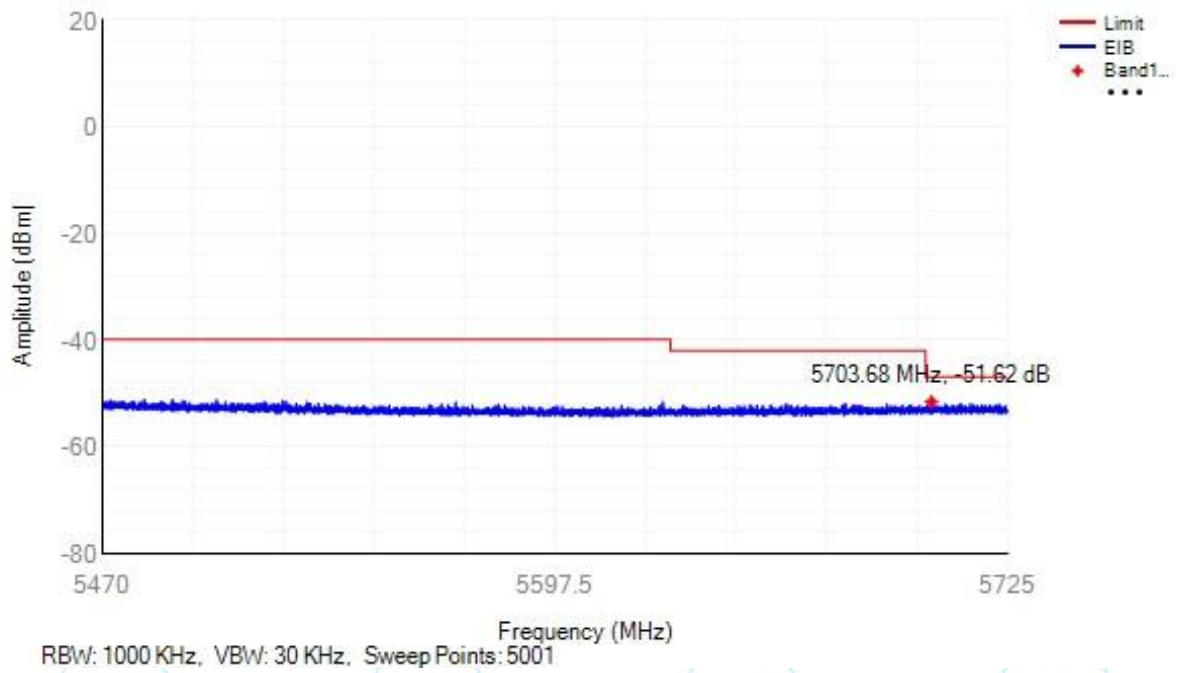

Frequency: 5319.00 MHz

Transmitter unwanted emissions within the 5 GHz RLAN bands

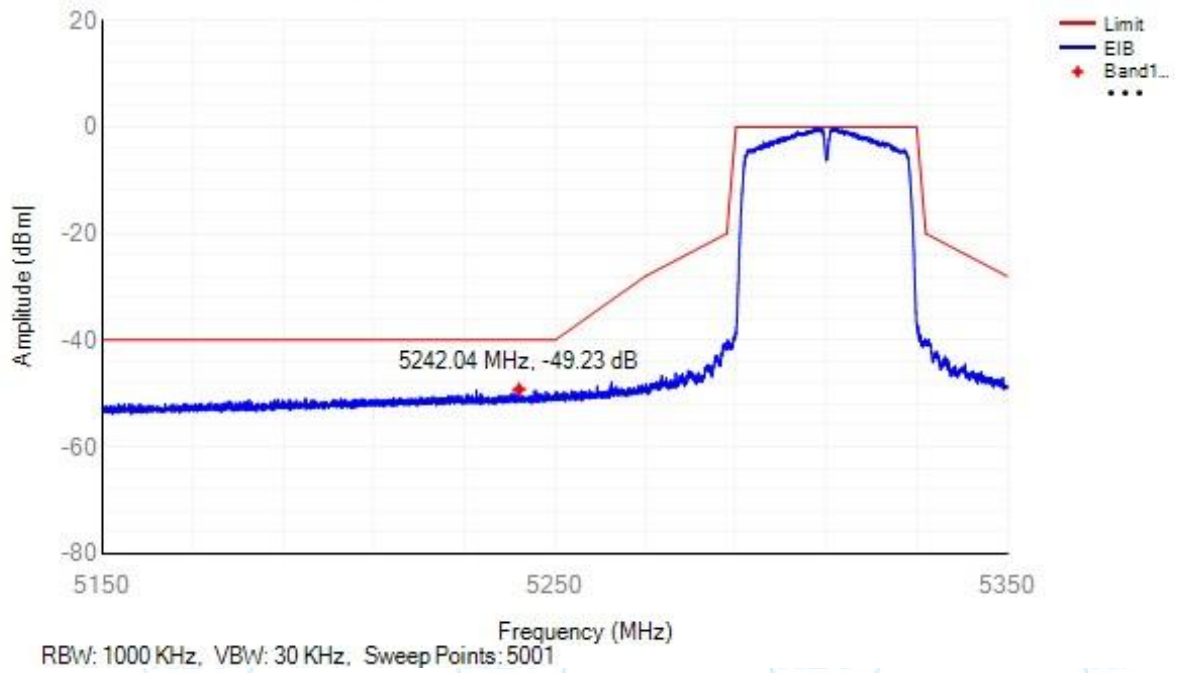

Tx. Emissions EIB NVNT ac40 5310MHz Sub Band2

Frequency: 5319.00 MHz

Transmitter unwanted emissions within the 5 GHz RLAN bands

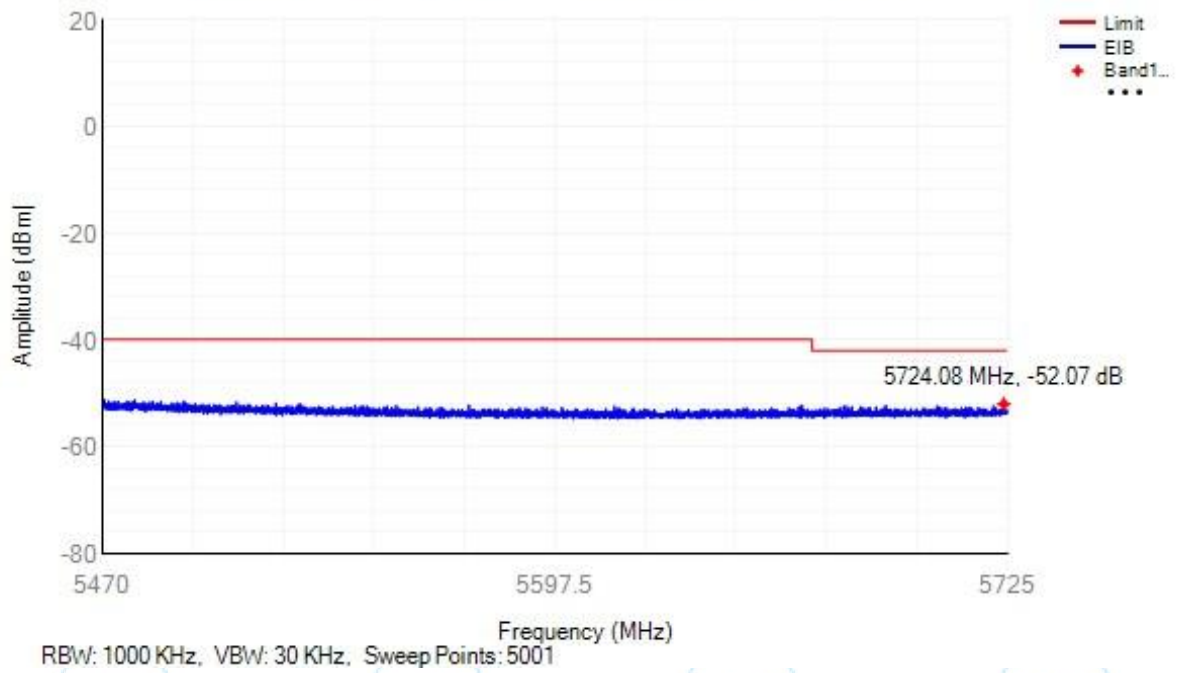

Frequency: 5290.00 MHz

Transmitter unwanted emissions within the 5 GHz RLAN bands

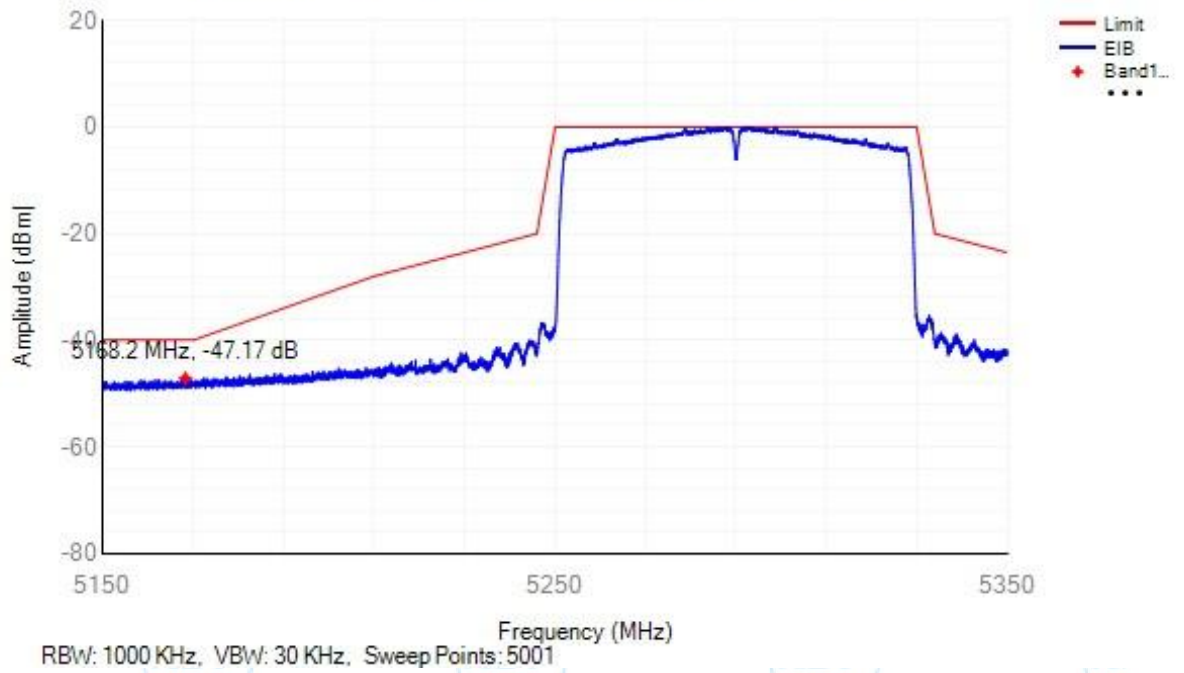

Tx. Emissions EIB NVNT ac80 5290MHz Sub Band2

Frequency: 5290.00 MHz

Transmitter unwanted emissions within the 5 GHz RLAN bands

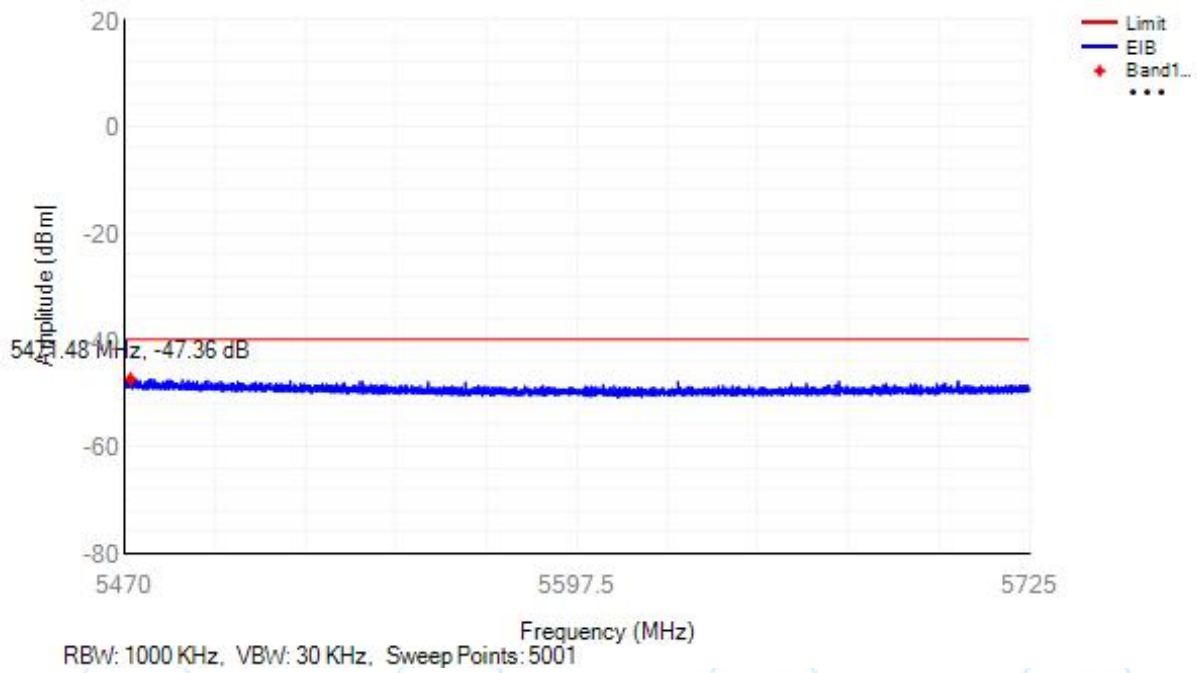

Frequency: 5269.00 MHz

Transmitter unwanted emissions within the 5 GHz RLAN bands

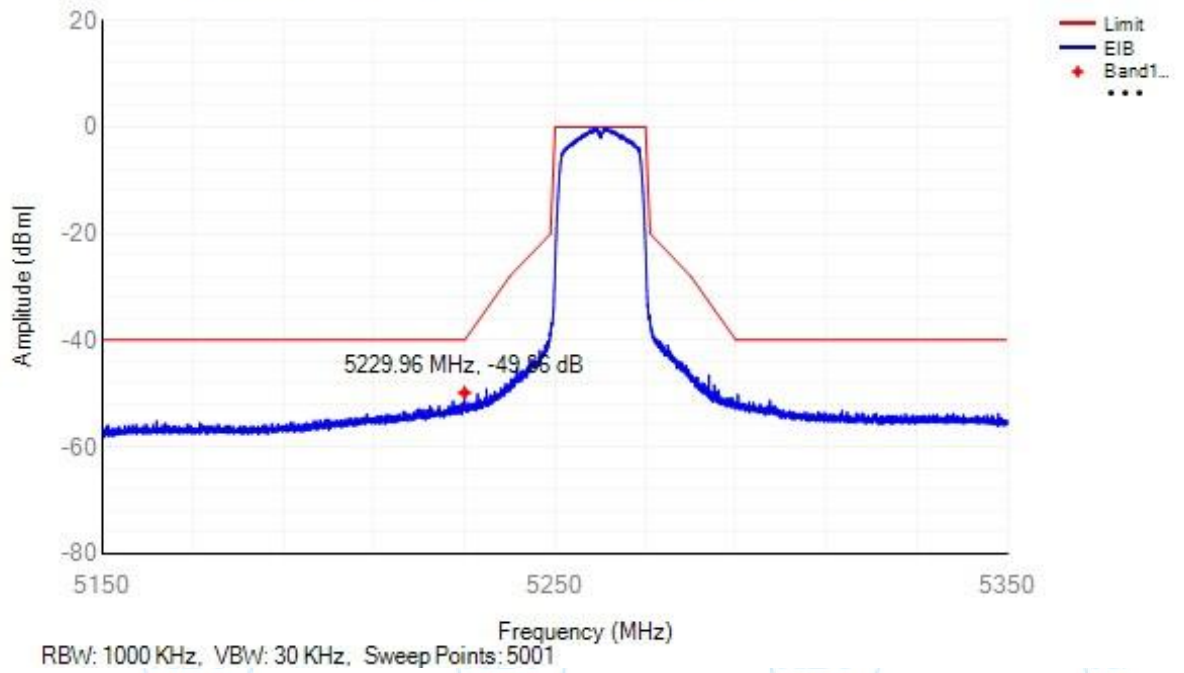

Tx. Emissions EIB NVNT n20 5260MHz Sub Band2

Frequency: 5269.00 MHz

Transmitter unwanted emissions within the 5 GHz RLAN bands

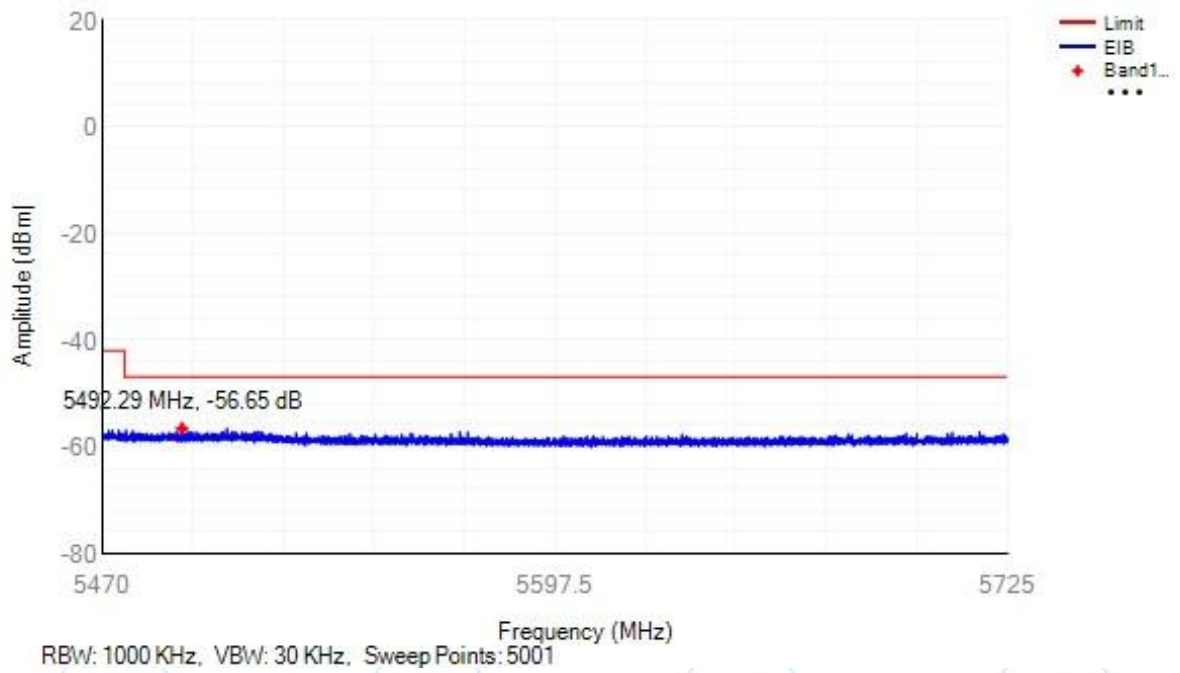

Frequency: 5280.00 MHz

Transmitter unwanted emissions within the 5 GHz RLAN bands

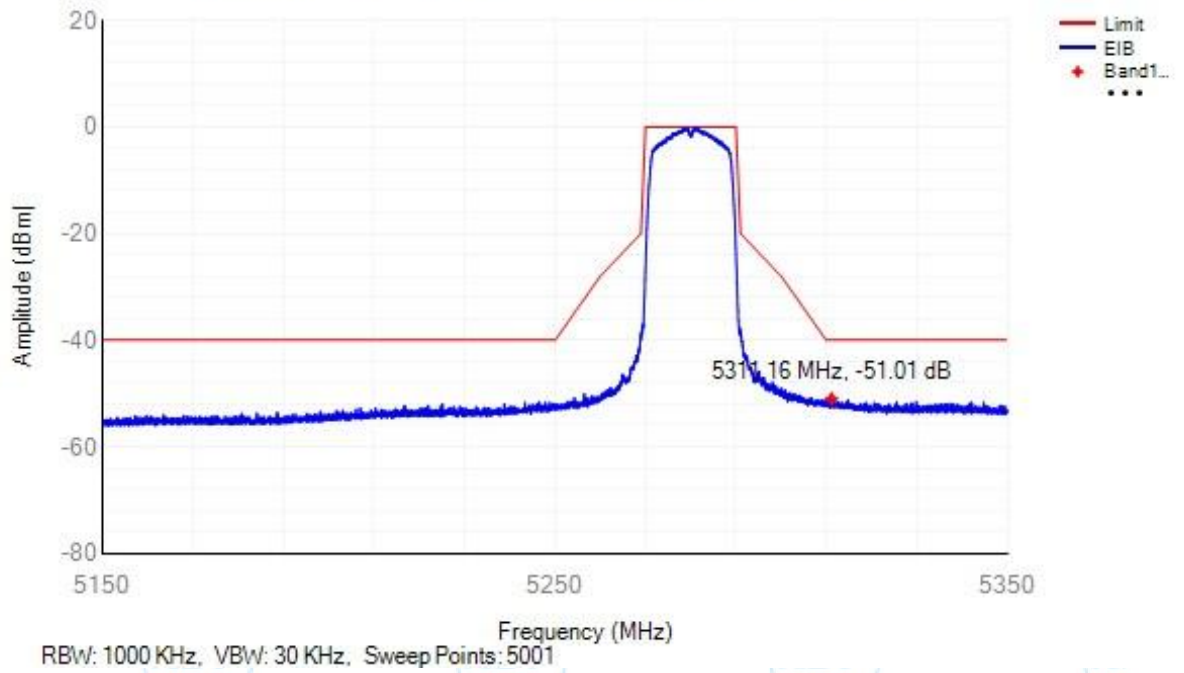

Tx. Emissions EIB NVNT n20 5280MHz Sub Band2

Frequency: 5280.00 MHz

Transmitter unwanted emissions within the 5 GHz RLAN bands

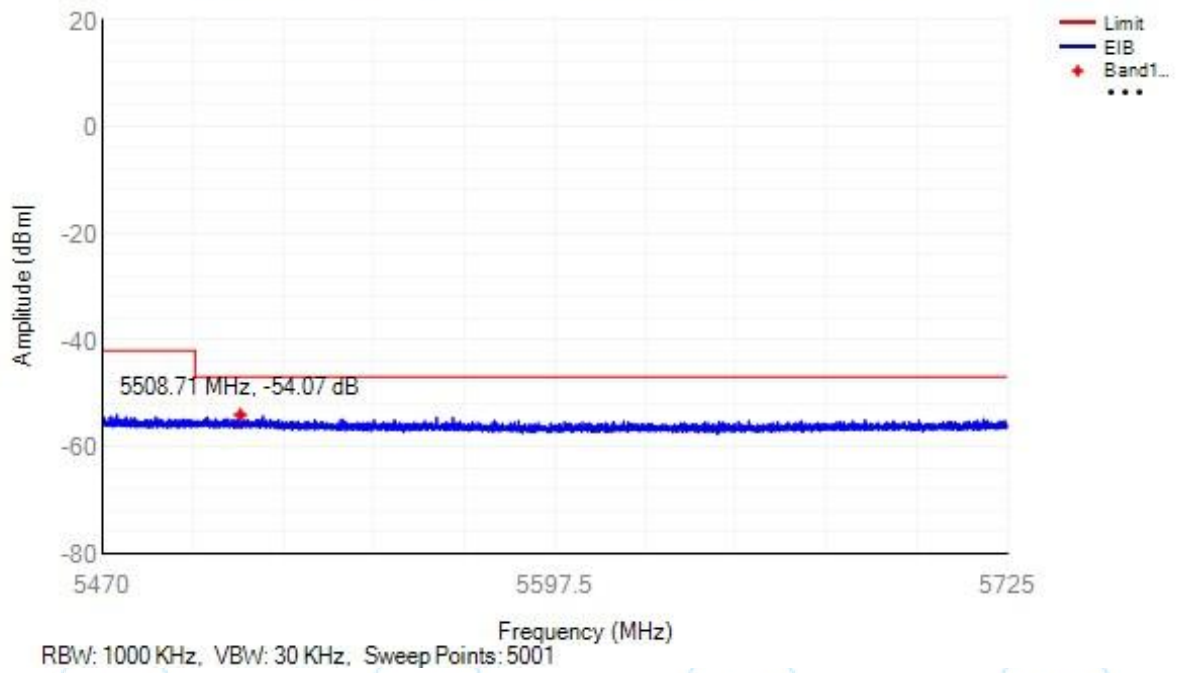

Frequency: 5329.00 MHz

Transmitter unwanted emissions within the 5 GHz RLAN bands

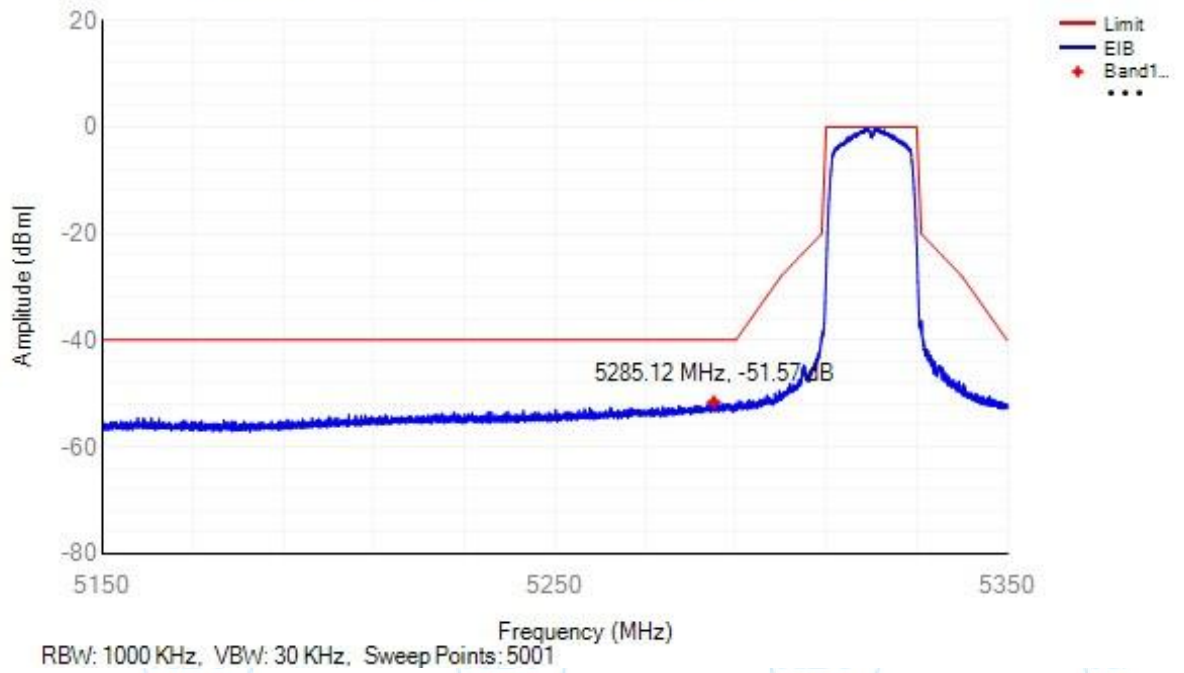

Tx. Emissions EIB NVNT n20 5320MHz Sub Band2

Frequency: 5329.00 MHz

Transmitter unwanted emissions within the 5 GHz RLAN bands

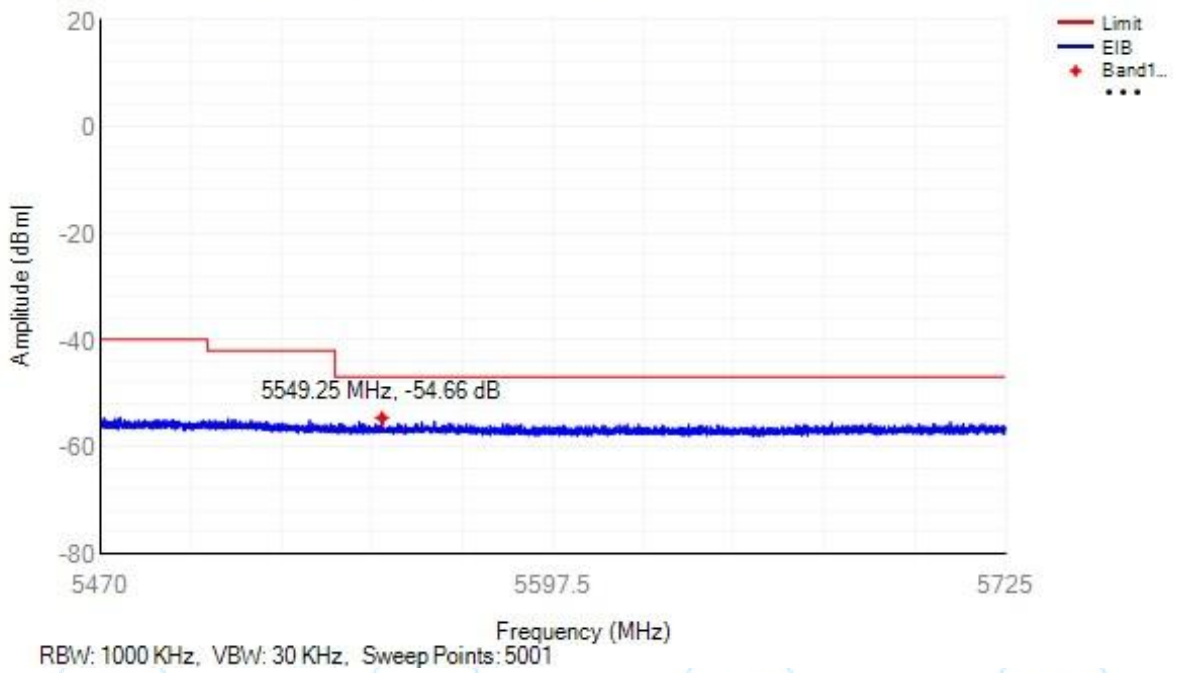

Frequency: 5279.00 MHz
Transmitter unwanted emissions within the 5 GHz RLAN bands

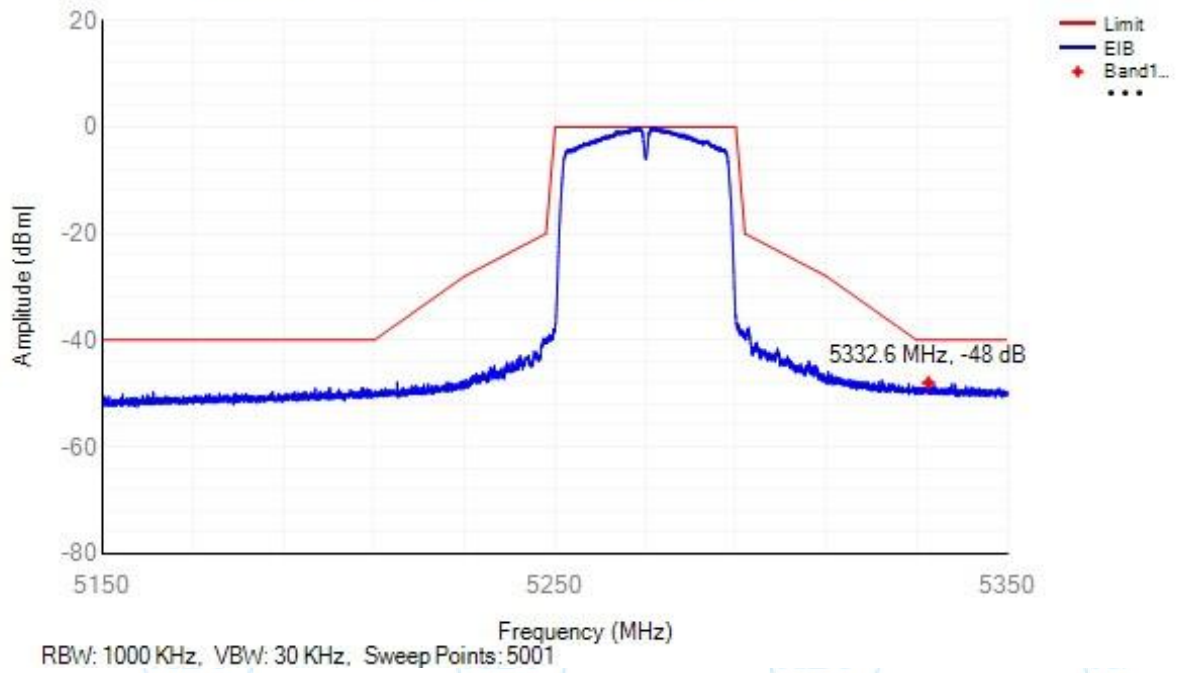

Tx. Emissions EIB NVNT n40 5270MHz Sub Band2

Frequency: 5279.00 MHz
Transmitter unwanted emissions within the 5 GHz RLAN bands

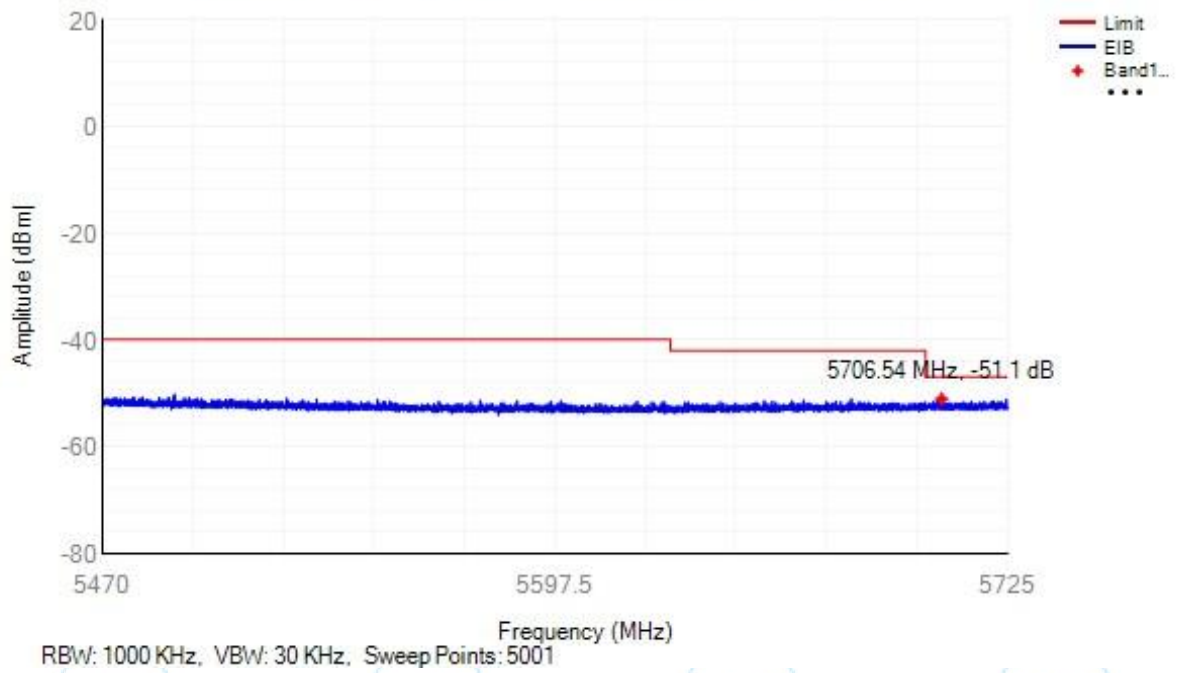

Frequency: 5319.00 MHz

Transmitter unwanted emissions within the 5 GHz RLAN bands

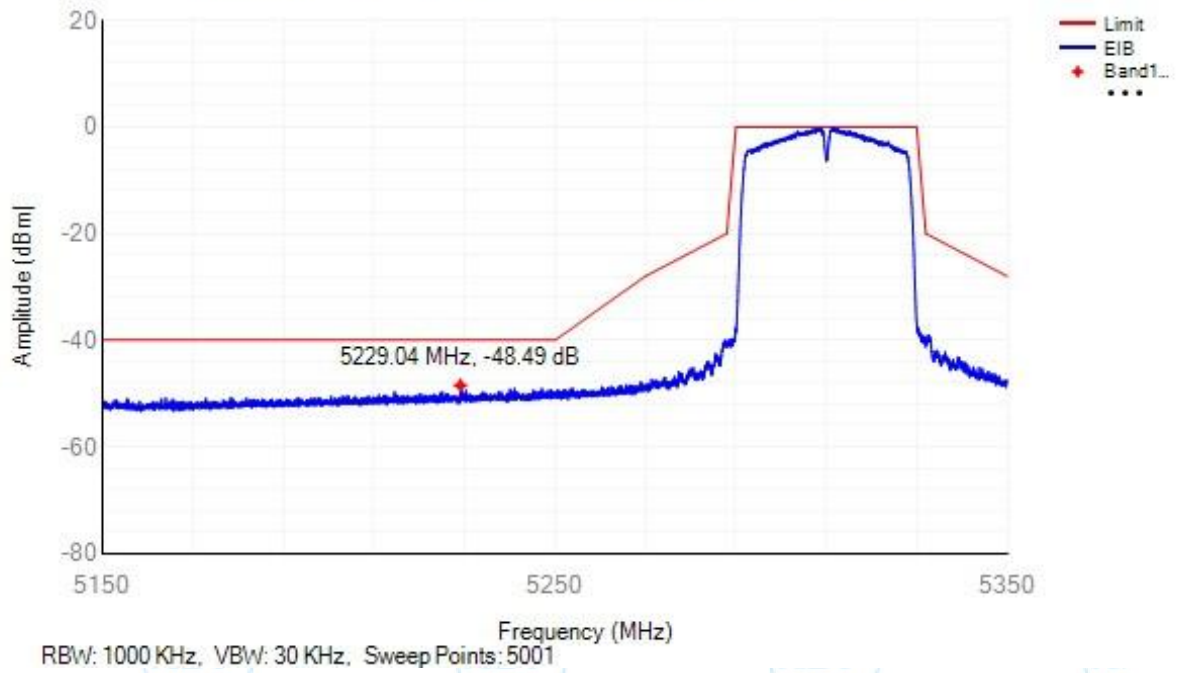

Tx. Emissions EIB NVNT n40 5310MHz Sub Band2

Frequency: 5319.00 MHz

Transmitter unwanted emissions within the 5 GHz RLAN bands

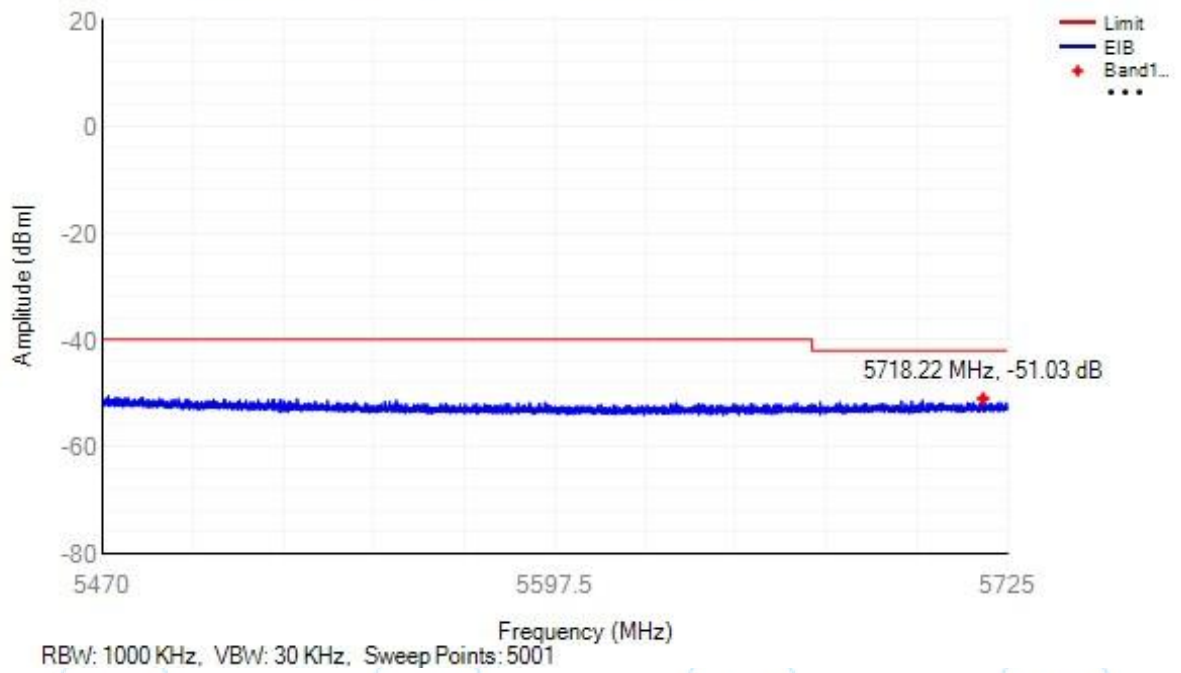

9. Receiver Spurious emissions

9.1. Limit

ETSI EN 301 893, Clause 4.2.5.2

Frequency range	Maximum power	Measurement bandwidth
30 MHz to 1 GHz	-57 dBm	100 kHz
1 GHz to 26 GHz	-47 dBm	1 MHz

9.2. Test Procedure

Radiated Measurement:

- (1) The EUT was placed on a 1.5m high table in the chamber and turned on in continuously RX mode.
- (2) All the spurious emissions from 30MHz to 26GHz at 3m distance was measured and recorded with receive antenna in both vertical and horizontal by rotating the turntable and by lowering the receive antenna, and the spectrum analyser was set as below
RBW:100KHz VBW:300KHz for 30-1000MHz
RBW:1MHz VBW:3MHz for above 1GHz
Detector mode: PEAK mode
Sweep time: Auto
- (3) The EUT was then removed and replaced with a substitution antenna in the same position and the substitution antenna must have the same polarization with the receive antenna.
- (4) A signal which have the same frequency obtained in step 2 was fed to the substitution antenna ,the receive antenna was raised and lowered to obtain a maximum reading at the test receiver, the level of the signal generator was adjusted until the measured field strength level in step 2 was obtained, recorded the level of the signal generator.
- (5) Repeated step 4 with both antenna polarizations
- (6) The spurious emissions is equal to the power supplied by the signal generator and corrections due to the gain of the substitution antenna and the cable loss between the signal generator and the substitution antenna.

9.3. Test Result

U-NII-1 :					
Test Mode: IEEE 802.11a RX in Lowest channel (5180MHz)					
Frequency (MHz)	Antenna polarization	Result (dBm)	Limit (dBm)	Margin (dB)	Conclusion
195.33	H	-64.40	-57	-7.40	Pass
283.87	H	-66.13	-57	-9.13	Pass
3586.01	H	-56.94	-47	-9.94	Pass
6865.73	H	-59.58	-47	-12.58	Pass
212.58	V	-68.87	-57	-11.87	Pass
284.95	V	-65.46	-57	-8.46	Pass
3278.63	V	-58.96	-47	-11.96	Pass
6135.41	V	-56.86	-47	-9.86	Pass
Test Mode: IEEE 802.11a RX in highest channel (5240MHz)					
Frequency (MHz)	Antenna polarization	Result (dBm)	Limit (dBm)	Margin (dB)	Conclusion
194.55	H	-64.25	-57	-7.25	Pass
274.79	H	-66.17	-57	-9.17	Pass
3580.02	H	-56.92	-47	-9.92	Pass
6858.68	H	-58.88	-47	-11.88	Pass
212.74	V	-68.74	-57	-11.74	Pass
284.46	V	-65.58	-57	-8.58	Pass
3277.54	V	-58.62	-47	-11.62	Pass
6139.24	V	-56.23	-47	-9.23	Pass

Note: This Report only show the test result of the worst case (U-NII-1 (IEEE 802.11a)).

10. DFS Parameters and Radar Waveforms Calibration

10.1. DFS Parameters

Table D.1: DFS requirement values

Parameter	Value
Channel Availability Check Time	60 s (see note 1)
Minimum Off-Channel CAC Time	6 minutes (see note 2)
Maximum Off-Channel CAC Time	4 hours (see note 2)
Channel Move Time	10 s
Channel Closing Transmission Time	1 s
Non-Occupancy Period	30 minutes
NOTE 1: For channels whose nominal bandwidth falls completely or partly within the band 5 600 MHz to 5 650 MHz, the <i>Channel Availability Check Time</i> shall be 10 minutes.	
NOTE 2: For channels whose nominal bandwidth falls completely or partly within the band 5 600 MHz to 5 650 MHz, the <i>Off-Channel CAC Time</i> shall be within the range 1 hour to 24 hours.	

Table D.2: Interference threshold values

e.i.r.p. Spectral Density (dBm/MHz)	Value (see notes 1 and 2)
10	-62 dBm
NOTE 1: This is the level at the input of the receiver of an RLAN device with a maximum e.i.r.p. density of 10 dBm/MHz and assuming a 0 dBi receive antenna. For devices employing different e.i.r.p. spectral density and/or a different receive antenna gain G (dBi) the DFS threshold level at the receiver input follows the following relationship: DFS Detection Threshold (dBm) = -62 + 10 - e.i.r.p. Spectral Density (dBm/MHz) + G (dBi); however the DFS threshold level shall not be less than -64 dBm assuming a 0 dBi receive antenna gain.	
NOTE 2: Slave devices with a maximum e.i.r.p. of less than 23 dBm do not have to implement radar detection unless these devices are used in fixed outdoor point to point or fixed outdoor point to multipoint applications (see clause 4.7.1.3).	

Table D.3: Parameters of the reference DFS test signal

Pulse width W [μs]	Pulse repetition frequency PRF [PPS]	Pulses per burst [PPB]
1	700	18

Table D.4: Parameters of radar test signals

Radar test signal # (see note 1 to note 3)	Pulse width W [µs]		Pulse repetition frequency PRF (PPS)		Number of different PRFs	Pulses per burst for each PRF (PPB) (see note 5)
	Min	Max	Min	Max		
1	0,5	5	200	1 000	1	10 (see note 6)
2	0,5	15	200	1 600	1	15 (see note 6)
3	0,5	15	2 300	4 000	1	25
4	20	30	2 000	4 000	1	20
5	0,5	2	300	400	2/3	10 (see note 6)
6	0,5	2	400	1 200	2/3	15 (see note 6)

NOTE 1: Radar test signals #1 to #4 are constant PRF based signals. See figure D.1. These radar test signals are intended to simulate also radars using a packet based Staggered PRF. See figure D.2.

NOTE 2: Radar test signal #4 is a modulated radar test signal. The modulation to be used is a chirp modulation with a $\pm 2,5$ MHz frequency deviation which is described below.

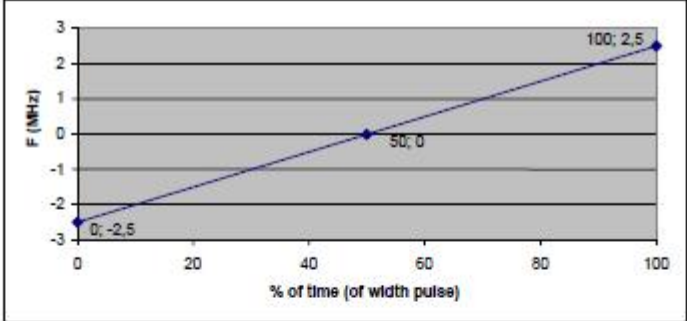

NOTE 3: Radar test signals #5 and #6 are single pulse based Staggered PRF radar test signals using 2 or 3 different PRF values. For radar test signal #5, the difference between the PRF values chosen shall be between 20 PPS and 50 PPS. For radar test signal #6, the difference between the PRF values chosen shall be between 80 PPS and 400 PPS. See figure D.3.

NOTE 4: Apart for the Off-Channel CAC testing, the radar test signals above shall only contain a single burst of pulses. See figure D.1, figure D.3 and figure D.4. For the Off-Channel CAC testing, repetitive bursts shall be used for the total duration of the test. See figure D.2 and figure D.5. See also clause 4.7.2.3, clause 5.3.8.2.1.4.2 and clause 5.3.8.2.1.4.3.

NOTE 5: The total number of pulses in a burst is equal to the number of pulses for a single PRF multiplied by the number of different PRFs used.

NOTE 6: For the CAC and Off-Channel CAC requirements, the minimum number of pulses (for each PRF) for any of the radar test signals to be detected in the band 5 600 MHz to 5 650 MHz shall be 18.

Table D.5: Detection probability

Parameter	Detection Probability (P_d)	
	Channels whose nominal bandwidth falls partly or completely within the 5 600 MHz to 5 650 MHz band	Other channels
CAC, Off-Channel CAC	99,99 %	60 %
In-Service Monitoring	60 %	60 %

NOTE: P_d gives the probability of detection per simulated radar burst and represents a minimum level of detection performance under defined conditions. Therefore P_d does not represent the overall detection probability for any particular radar under real life conditions.

10.2. Radar Waveform Calibration

The following equipment setup was used to calibrate the conducted Radar Waveform. A spectrum analyzer was used to establish the test signal level for each radar type. During this process there were no transmissions by either the Master or Client Device.

The spectrum analyzer was switched to the zero span (Time Domain) mode at the frequency of the Radar Waveform generator. Peak detection was utilized. The spectrum analyzer resolution bandwidth (RBW) and video bandwidth (VBW) were set to 3 MHz. The signal generator amplitude was set so that the power level measured at the spectrum analyzer was -64dBm.

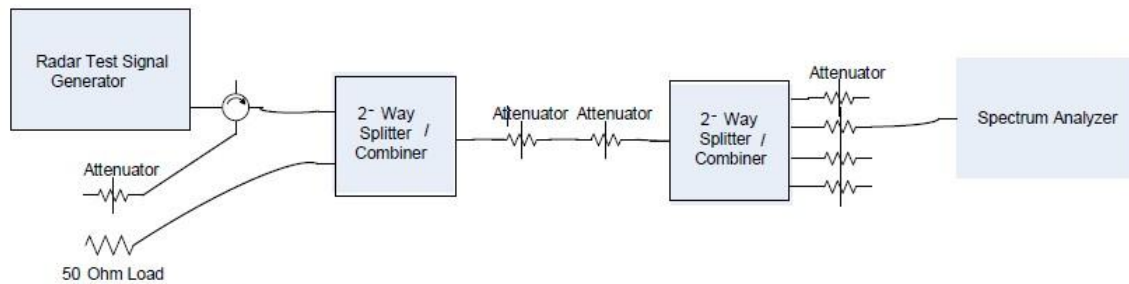

Conducted Calibration Setup

10.3. DFS – Test Parameter

10.3.1 DFS

Measurement

MethodsType

Radar Reporting

Notes

The delta marker is set at the end of the last WLAN transmission following the radar pulse. This delta is the channel move time. The aggregate channel closing transmission time is calculated as follows: $\text{Aggregate Transmission Time} = (\text{Number of analyzer bins showing transmission}) * (\text{dwell time per bin})$ The observation period over which the aggregate time is calculated Begins at (Reference Marker) And Ends noearlier than (Reference Marker + 10 sec).

a. DFS – CHANNEL CLOSING TRANSMISSION TIME AND CHANNEL MOVE TIME

Channel clearing and closing times are measured by applying a burst of radar with the device configured to change channel and by observing the channel for transmissions. The time between the end of the applied radar waveform and the final transmission on the channel is the channel move time.

The aggregate transmission closing time is measured in one of two ways: ETSI1 – the total time of all individual transmissions from the EUT that are observed from the end of the last radar pulse in the waveform. This value is required to be less than 1s.

b. DFS – CHANNEL NON-OCCUPANCY AND VERIFICATION OF PASSIVE SCANNING

The channel that was in use prior to radar detection by the master is additionally

monitored for 30 minutes to ensure no transmissions on the vacated channel over therequired non-occupancy period. This is achieved by tuning the spectrum analyzer to the vacated channel in zero-span mode and connecting the IF output to an oscilloscope. The oscilloscope is triggered by the radar pulse and set to provide a single sweep (in peak detect mode) that lasts for at least 30 minutes after the end of the channel move time.

c. CHANNEL AVAILABILITY CHECK TIME

It is preferred that the EUT report when it starts the radar channel availability check. If the EUT does not report the start of the check time, then the time to start transmitting on a channel after switching the device on is measured to approximate the time from power on to the end of the channel availability check. The start of the channel availability check is assumed to be 60 seconds prior to the first transmission on the channel. To evaluate the channel availability check, a single burst of one radar type is applied within the first 2 seconds of the start of the channel availability check and it is verified that the device does not use the channel by continuing to monitor the channel for a period of at least 60 seconds. The test is repeated by applying a burst of radar in the last 2 seconds (i.e. between 58 and 60 seconds after the start of CAC) of the channel availability check.

d. CONTROL (TPC)

Compliance with the transmit power control requirements for devices is demonstrated through measurements showing multiple power levels and manufacturer statements explaining how the power control is implemented.

e. DETECTION PROBABILITY / SUCCESS RATE

The detection probability, or success rate, for any one radar waveform equals the number of successful trials divided by the total number of trials for that waveform.

f. SHOLD LEVEL

The threshold level is to simulate radar waveform rf way. If the test is performed in a conducted fashion then the level at the rf input equals the level at the antenna plus the gain of the antenna assembly, in dBi. The gain of the antenna assembly equals the gain of the antenna minus the loss of the cabling between the rf input and the antenna. The lowest gain value for all antenna assemblies intended for use with the device is used when making this calculation. If the test is performed using the radiated method then the threshold level is the level at the antenna.

10.3.2 DFS Conduction Test Method

a. The signal level of the simulated waveform is set to a reference level equal to the threshold level (plus 1dB if testing against EU requirements). Lower levels may also be applied on request of the manufacturer.

The signal level is verified by measuring the CW signal level at the coupling point to the RDD antenna port. The radar signal level is calculated from the measured level, R(dBm) and the lowest gain antenna assembly intended for use with the RDD

If both master and client devices have radar detection capability then the radar level at the non RDD is verified to be at least 20dB below the threshold level to ensure that any responses are due to the RDD detecting radar.

The antenna connected to the channel monitoring subsystem is positioned to allow both master and client transmissions to be observed, with the level of the EUT's transmissions between 6 and 10dB higher than those from the other device.

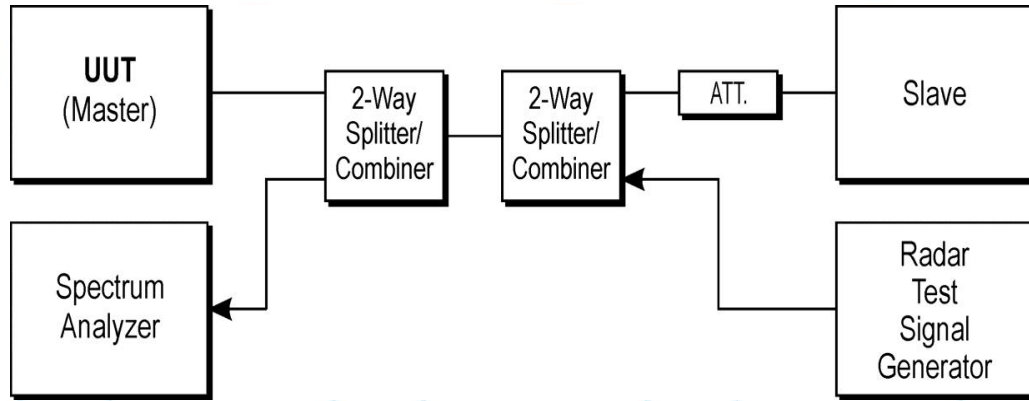

b. Set-up A is a set-up whereby the UUT is an RLAN device operating in master mode. Radar test signals are injected into the UUT. This set-up also contains an RLAN device operating in slave mode which is associated with the UUT. Figure 4 shows an example for Set-up A. The set-up used shall be documented in the test report.

10.4. DFS –Test Results

10.4.1 Channel Closing Transmission Time and Channel Move Time

Standard	Item	Requirement	Applicable
EN 301 893 V2.1.1	5.4.8.2.1.6	To Verify The Channel Shutdown Process And To Determine The Channel Closing Transmission Time And Channel Move Time.	Y

Shutdown Time

Mode	Frequency (MHz)	Channel Move Time (s)	Limit Channel Move Time (s)	Close Transmission Time (s)	Limit Close Transmission Time (s)	Verdict
a	5300	0.0726	10	0.0008	1	Pass
ac20	5300	0.0622	10	0.0008	1	Pass
n20	5300	0	10	0	1	Pass

Remark: Tests were performed using the conduction test method.

a 5300MHz Shutdown

Channel Shutdown

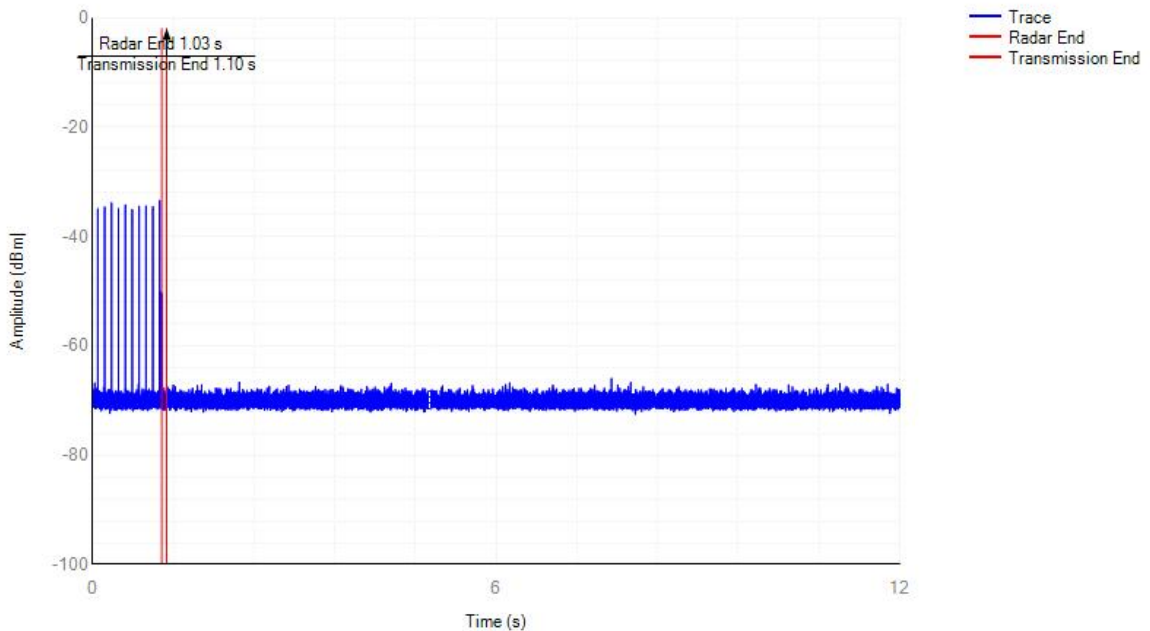

ac20 5300MHz Shutdown

Channel Shutdown

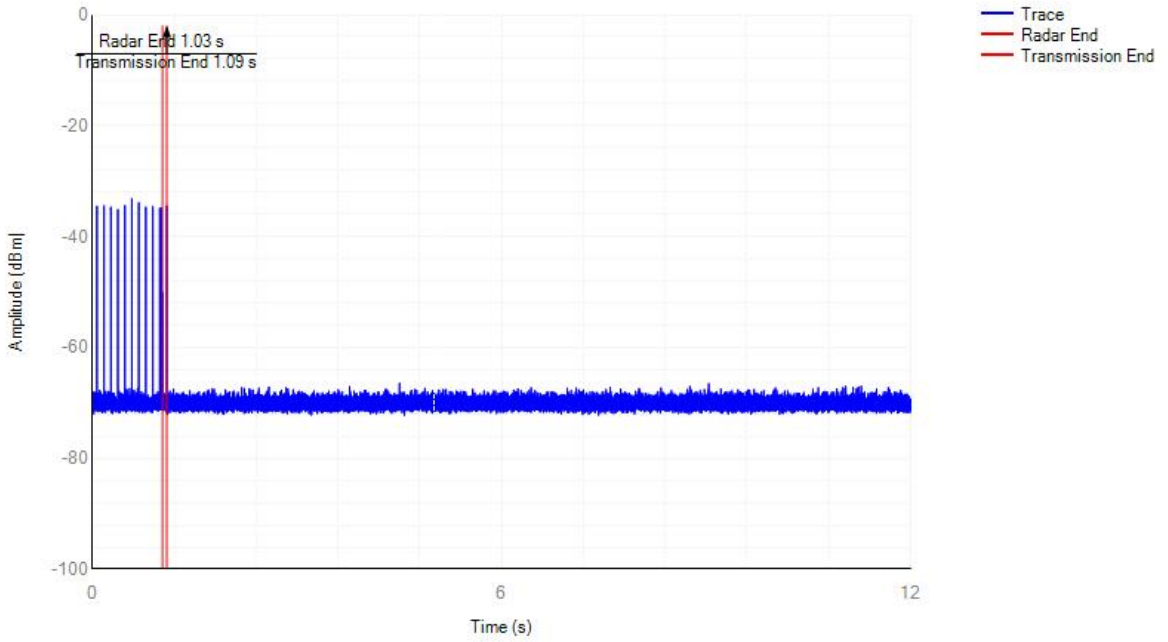

n20 5300MHz Shutdown

Channel Shutdown

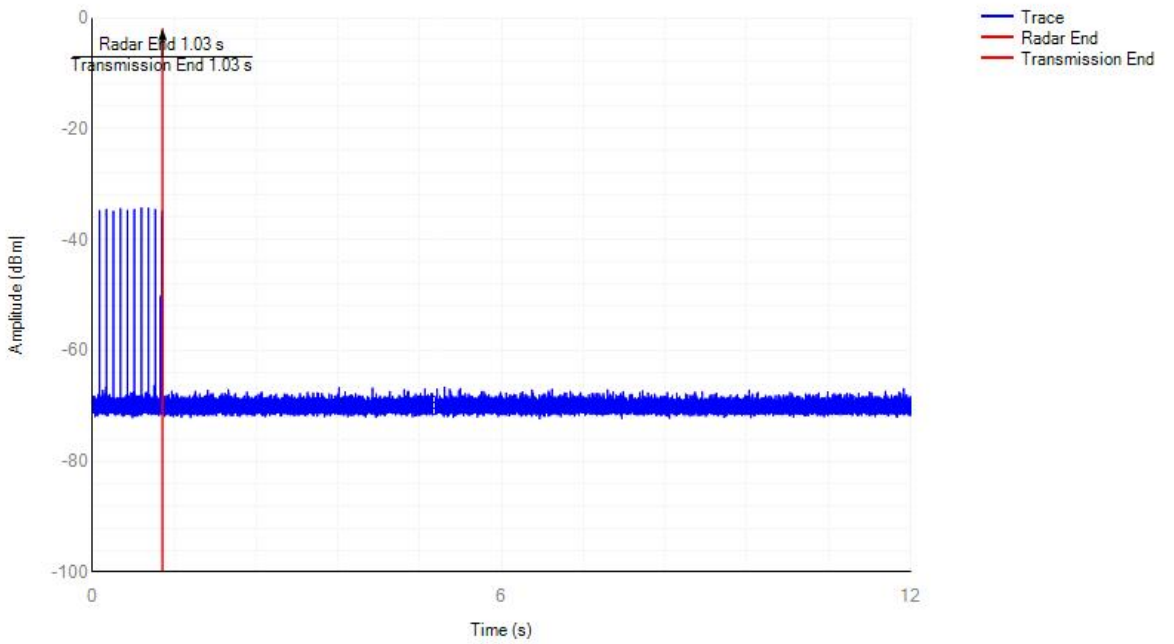

Note: This Report only show the test result of the worst case..

10.4.2 Non-Occupancy Period

Standard	Item	Requirement	Applicable
EN 301 893 V2.1.1	5.4.8.2.1.6	To verify the Channel Shutdown process and to determine the Non-Occupancy Period.	N/A

Not applicable.

EUT is a passive device and has no radar wave detection function.

10.4.3 Radar Detection Threshold

Standard	Item	Requirement	Applicable
EN 301 893 V2.1.1	5.4.8.2.1.3	Radar detection threshold needs to be checked during the Channel Availability Check	N/A

Not applicable.

EUT is a passive device and has no radar wave detection function.

10.4.4 In-Service Monitoring

Standard	Item	Requirement	Applicable
EN 301 893 V2.1.1	5.4.8.2.1.5	To verify the In-Service Monitoring and the Radar Detection Threshold during the In- Service Monitoring.	N/A

Not applicable.

EUT is a passive device and has no radar wave detection function.

10.4.5 Channel Availability Check Time

Standard	Item	Requirement	Applicable
EN 301 893 V2.1.1	Table D.1	Initial Channel Availability Check Time > 60 sec, (> 10 minutes for 5600-5650MHz)	N/A
	5.4.8.2.1.2.2	Tests with a radar burst at the beginning of the Channel Availability Check Time	N/A
	5.4.8.2.1.2.3	Tests with a radar burst at the end of the Channel Availability Check Time	N/A
	5.4.8.2.1.4 & 5.3.1.2 Table 6	Off-Channel CAC	N/A

Not applicable.

EUT is a passive device and has no radar wave detection function.

11.

Adaptivity

11.1.

Limit

Adaptivity is an automatic channel access mechanism by which a device avoids transmissions in a channel in the presence of transmissions from other RLAN systems in that channel.

<p>The Fixed Frame Periods supported by the equipment shall be declared by the manufacturer. See clause 5.4.1, item q). This shall be within the range of 1 ms to 10 ms. Transmissions can start only at the beginning of a Fixed Frame Period. See figure 2 below. An equipment may change its Fixed Frame Period but it shall not do more than once every 200 ms</p> <p>Occupancy Time: 1 ms to 10 ms</p> <p>Max change its Fixed Frame Period: 200 ms</p>
<p>The <i>ED Threshold Level (TL)</i>, at the input of the receiver, shall be proportional to the maximum transmit power (PH) according to the formula which assumes a 0 dBi receive antenna and PH to be specified in dBm e.i.r.p.</p> <p>For $PH \leq 13$ dBm: $TL = -75$ dBm/MHz</p> <p>For 13 dBm $< PH < 23$ dBm: $TL = -85$ dBm/MHz + (23 dBm - PH)</p> <p>For $PH \geq 23$ dBm: $TL = -85$ dBm/MHz</p>
<p>LBT based Detect and Avoid (Load Based Equipment):</p> <ol style="list-style-type: none"> 1 Minimum Clear Channel Assessment (CCA) time = 25 μs; 2 CCA declared by the manufacturer; 3 For $PH \leq 13$ dBm: $TL = -75$ dBm/MHz For 13 dBm $< PH < 23$ dBm: $TL = -85$ dBm/MHz + (23 dBm - PH) For $PH \geq 23$ dBm: $TL = -85$ dBm/MHz
<ol style="list-style-type: none"> 1. within an observation period of 50 ms, the number of Short Control Signalling Transmissions by the equipment shall be equal to or less than 50; 2. the total duration of the equipment's Short Control Signalling Transmissions shall be less than 2 500 μs within said observation period.

11.2. Test Setup

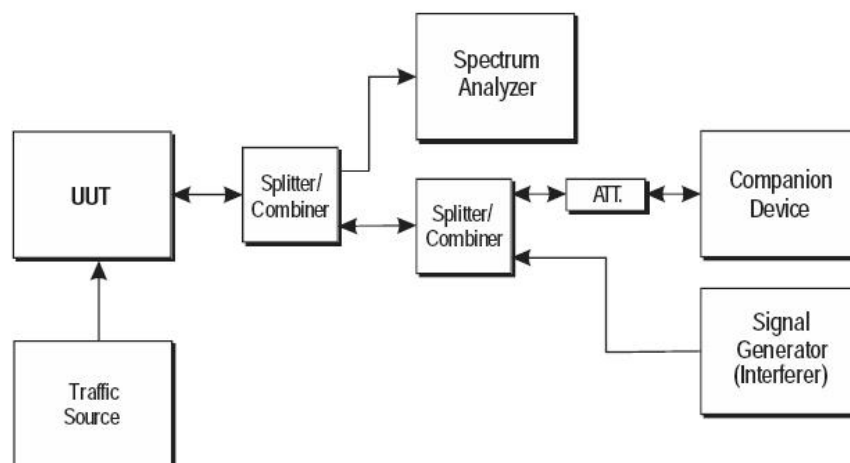

11.3. Test Procedure

Refer to ETSI EN 301 893 V2.1.1 Clause 5.4.9.

11.4. Test Result

U-NII-1

Adaptivity

Condition	Mode	Frequency (MHz)	Antenna	Interfer Type	Interfer Level (dBm)	Short Control (ms)	Limit (ms)	Short Control (n)	Limit (n)	Verdict
NVNT	a	5180	Ant1	AWGN	-75	0	<=2.5	0	<=50	Pass
NVNT	a	5180	Ant1	LTE	-75	0	<=2.5	0	<=50	Pass
NVNT	a	5180	Ant1	OFDM	-75	0	<=2.5	0	<=50	Pass
NVNT	a	5240	Ant1	AWGN	-75	0	<=2.5	0	<=50	Pass
NVNT	a	5240	Ant1	LTE	-75	0	<=2.5	0	<=50	Pass
NVNT	a	5240	Ant1	OFDM	-75	0	<=2.5	0	<=50	Pass
NVNT	ac20	5180	Ant1	AWGN	-75	0	<=2.5	0	<=50	Pass
NVNT	ac20	5180	Ant1	LTE	-75	0	<=2.5	0	<=50	Pass
NVNT	ac20	5180	Ant1	OFDM	-75	0	<=2.5	0	<=50	Pass
NVNT	ac20	5240	Ant1	AWGN	-75	0	<=2.5	0	<=50	Pass
NVNT	ac20	5240	Ant1	LTE	-75	0	<=2.5	0	<=50	Pass
NVNT	ac20	5240	Ant1	OFDM	-75	0	<=2.5	0	<=50	Pass
NVNT	n20	5180	Ant1	AWGN	-75	0	<=2.5	0	<=50	Pass
NVNT	n20	5180	Ant1	LTE	-75	0	<=2.5	0	<=50	Pass
NVNT	n20	5180	Ant1	OFDM	-75	0	<=2.5	0	<=50	Pass
NVNT	n20	5240	Ant1	AWGN	-75	0	<=2.5	0	<=50	Pass
NVNT	n20	5240	Ant1	LTE	-75	0	<=2.5	0	<=50	Pass
NVNT	n20	5240	Ant1	OFDM	-75	0	<=2.5	0	<=50	Pass

Adaptivity NVNT a 5180MHz AWGN

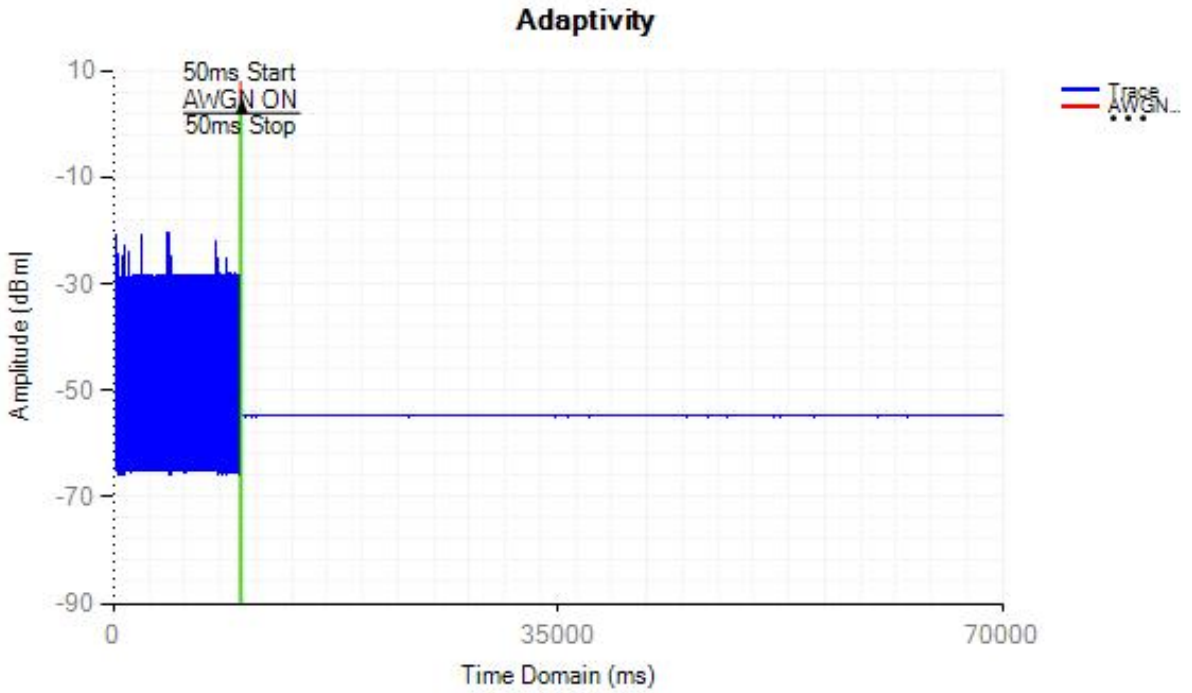

Control Signal NVNT a 5180MHz AWGN

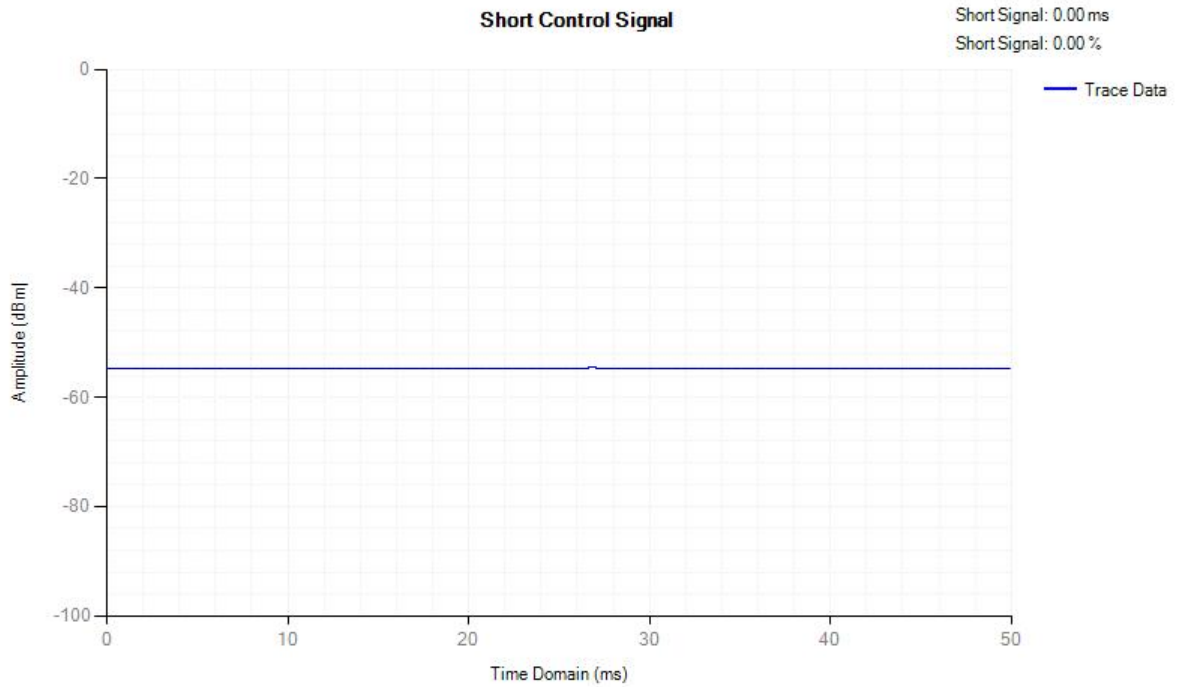

Adaptivity NVNT a 5180MHz LTE

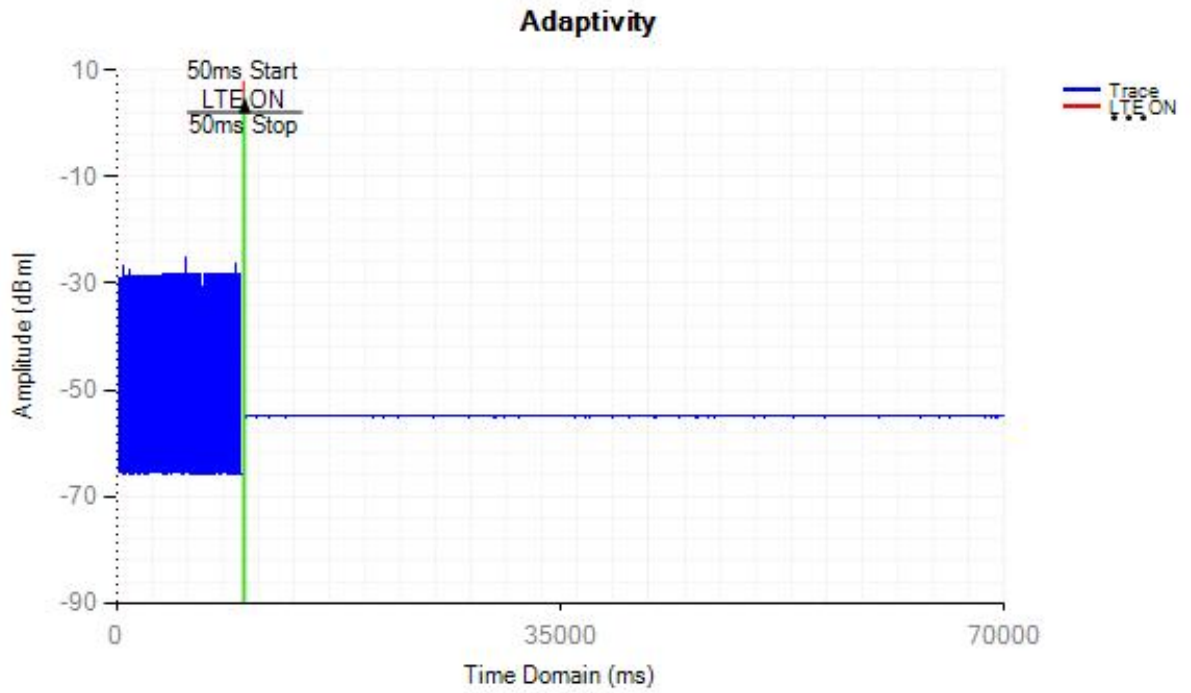

Control Signal NVNT a 5180MHz LTE

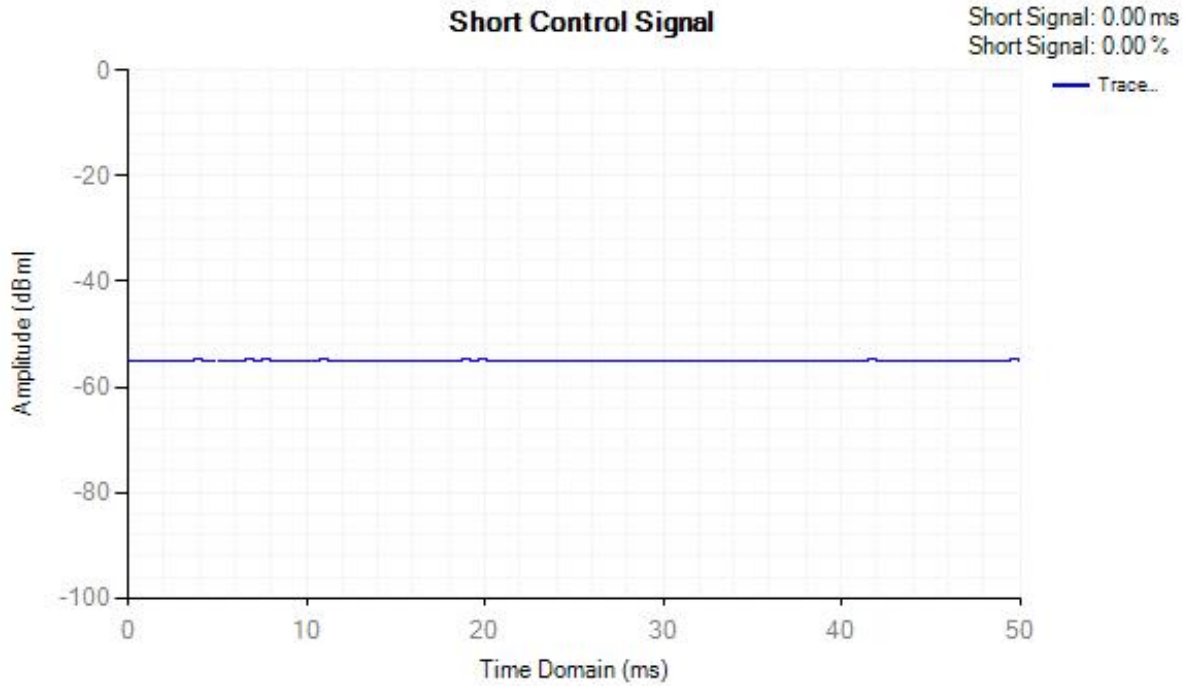

Adaptivity NVNT a 5180MHz OFDM

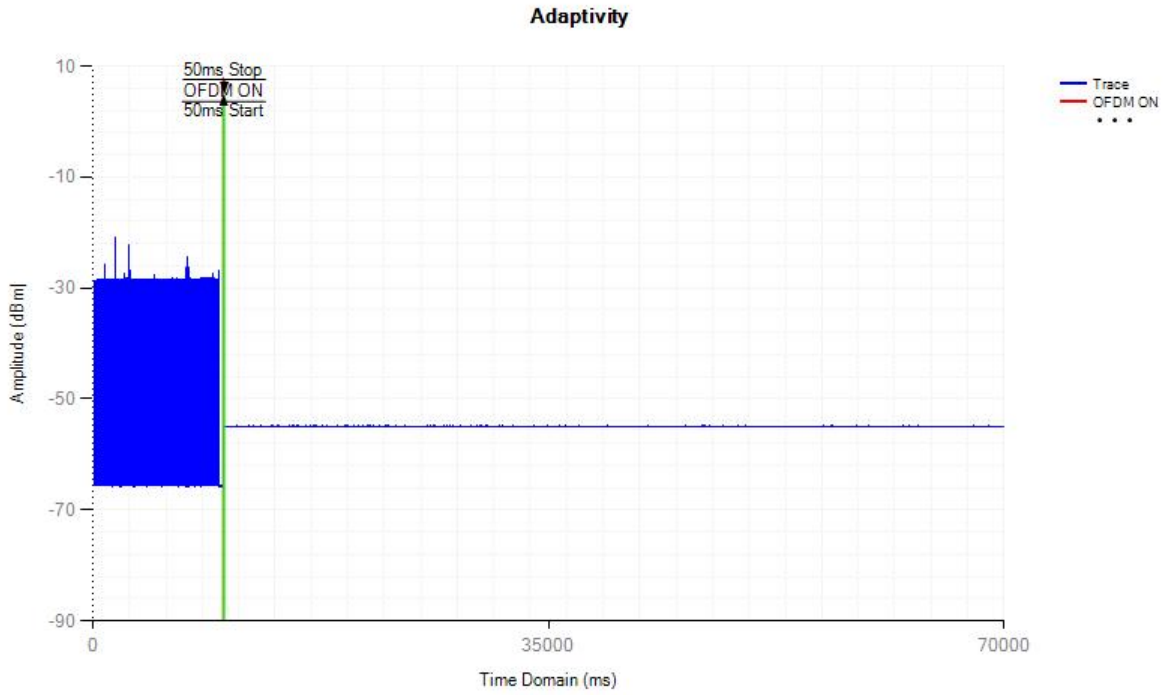

Control Signal NVNT a 5180MHz OFDM

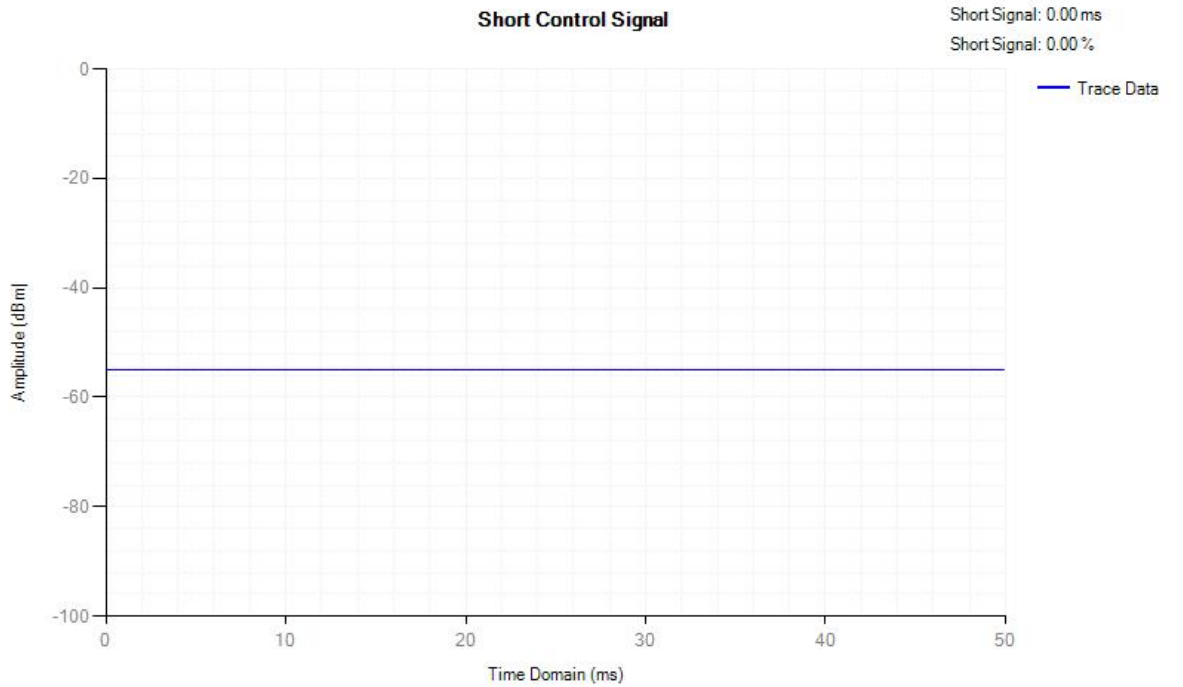

Adaptivity NVNT a 5240MHz AWGN

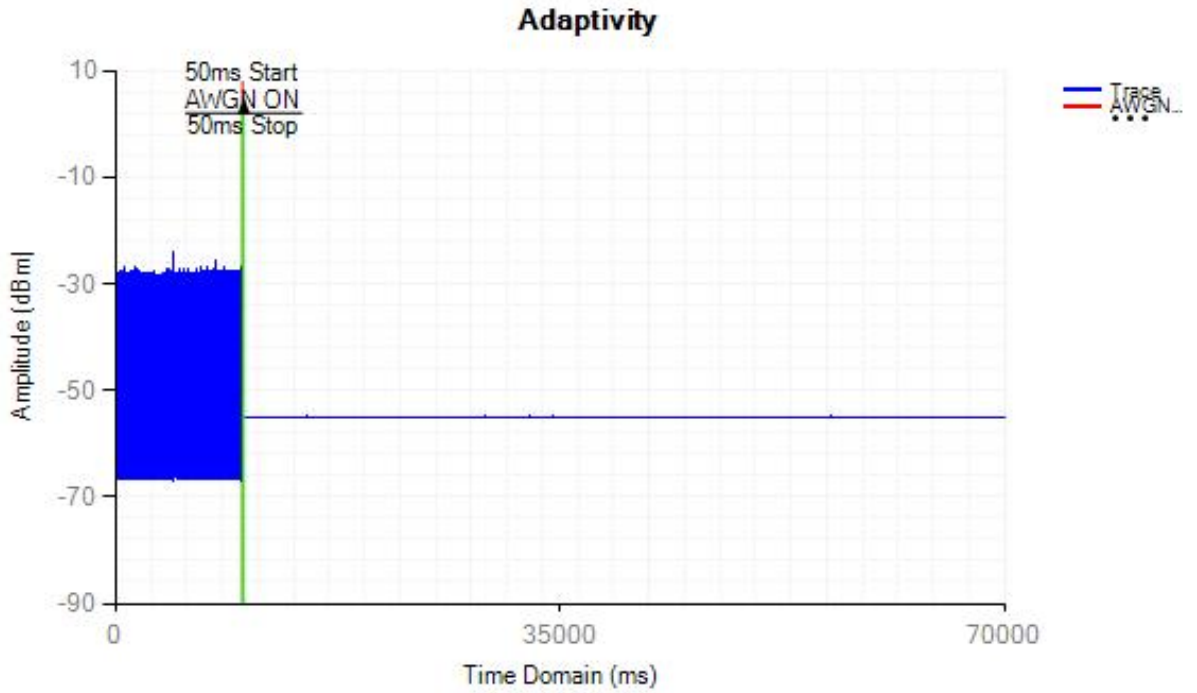

Control Signal NVNT a 5240MHz AWGN

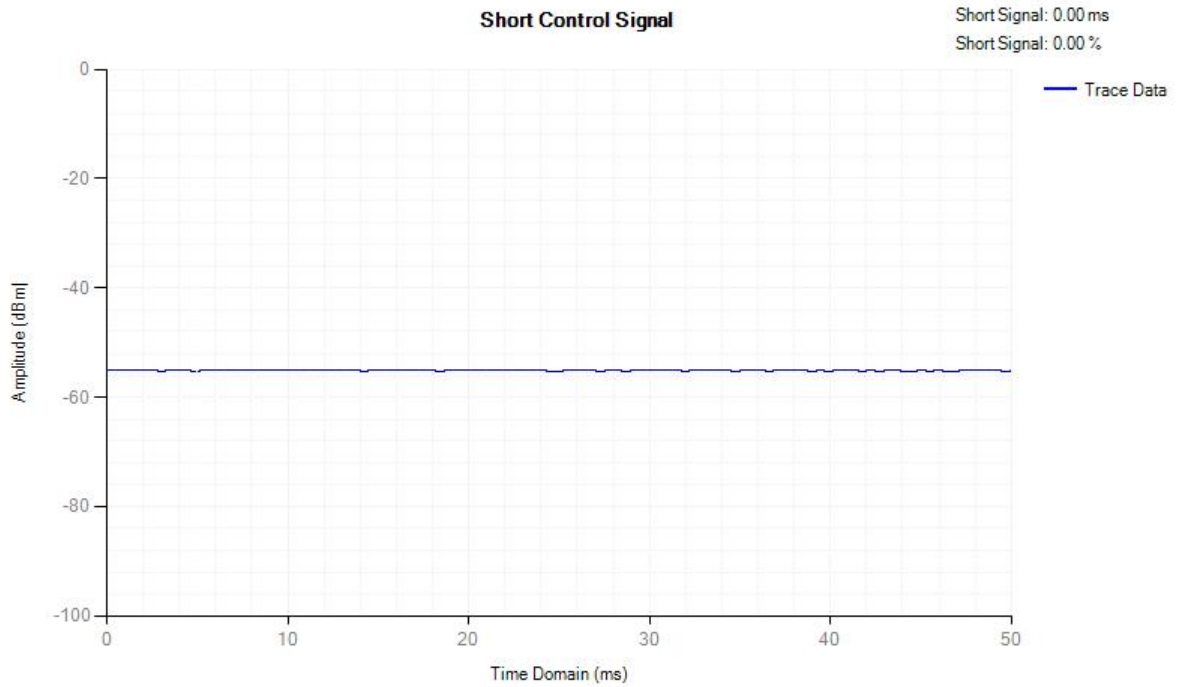

Adaptivity NVNT a 5240MHz LTE

Adaptivity

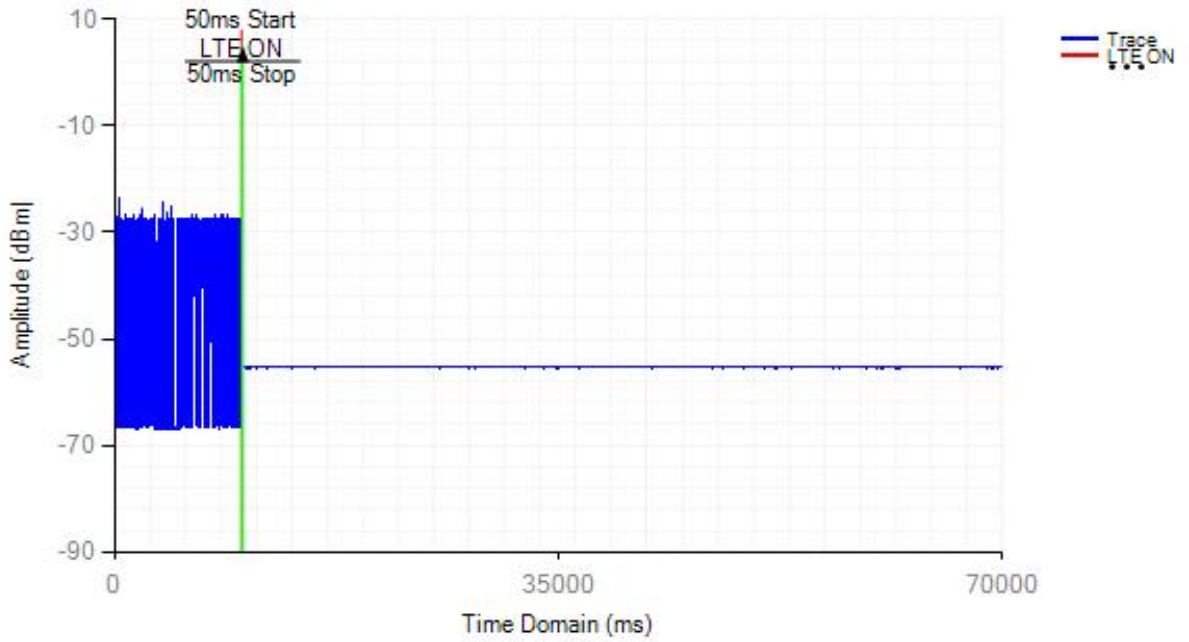

Control Signal NVNT a 5240MHz LTE

Short Control Signal

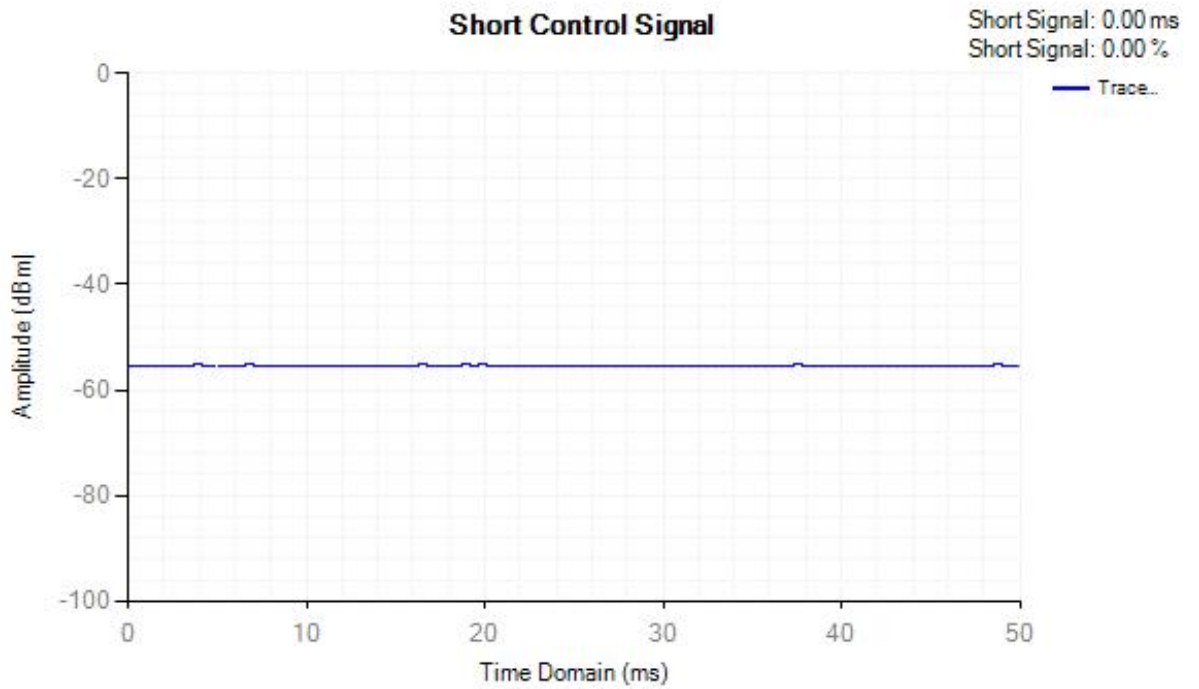

Adaptivity NVNT a 5240MHz OFDM

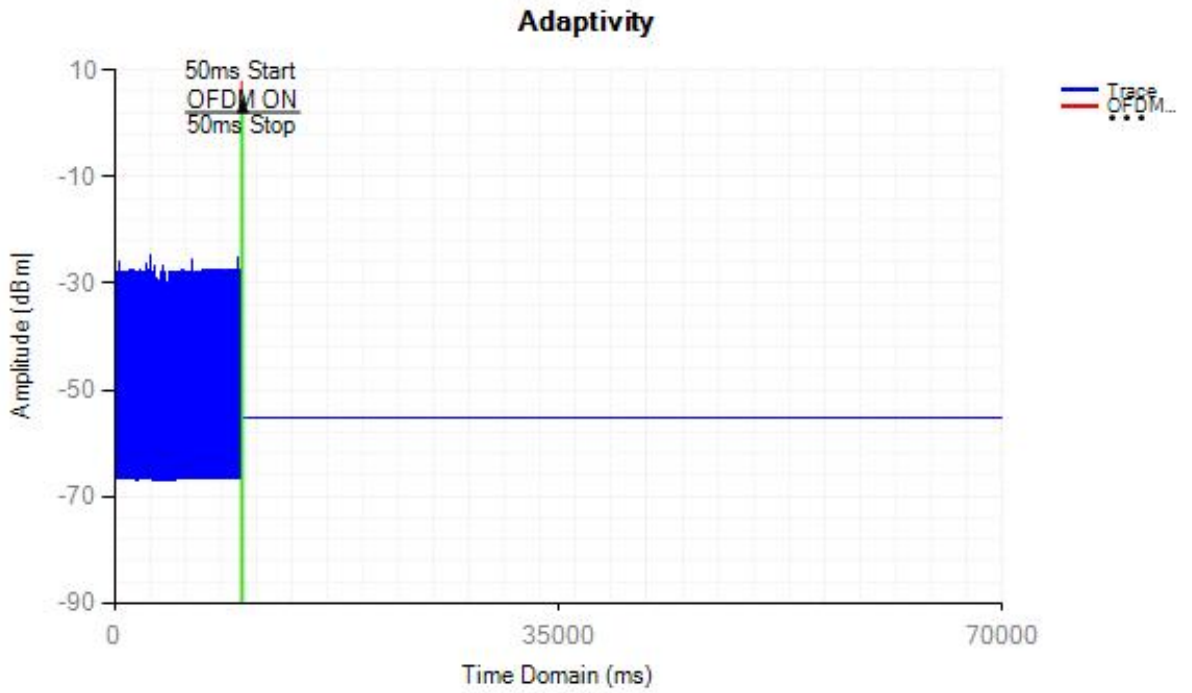

Control Signal NVNT a 5240MHz OFDM

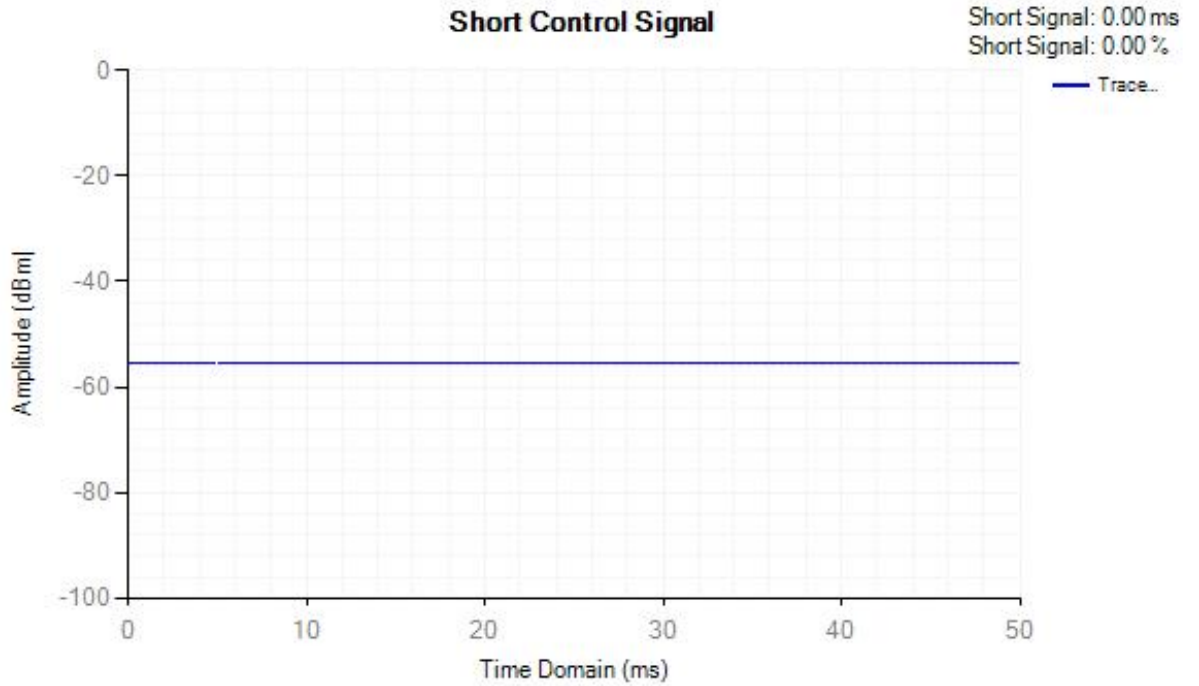

Adaptivity NVNT ac20 5180MHz AWGN

Adaptivity

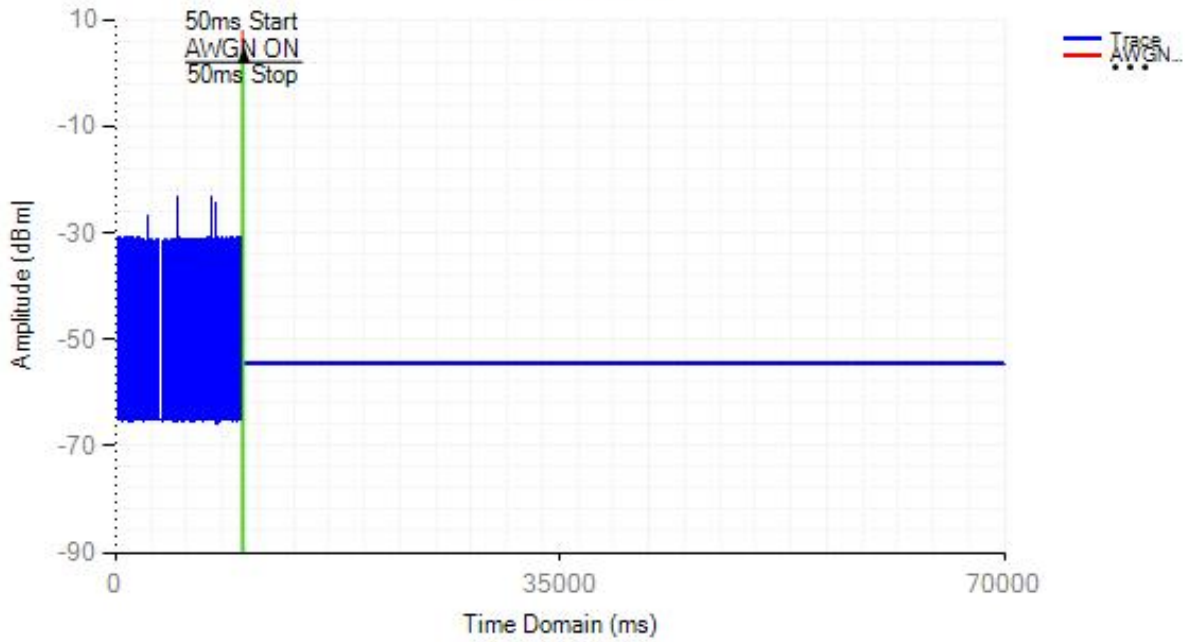

Control Signal NVNT ac20 5180MHz AWGN

Short Control Signal

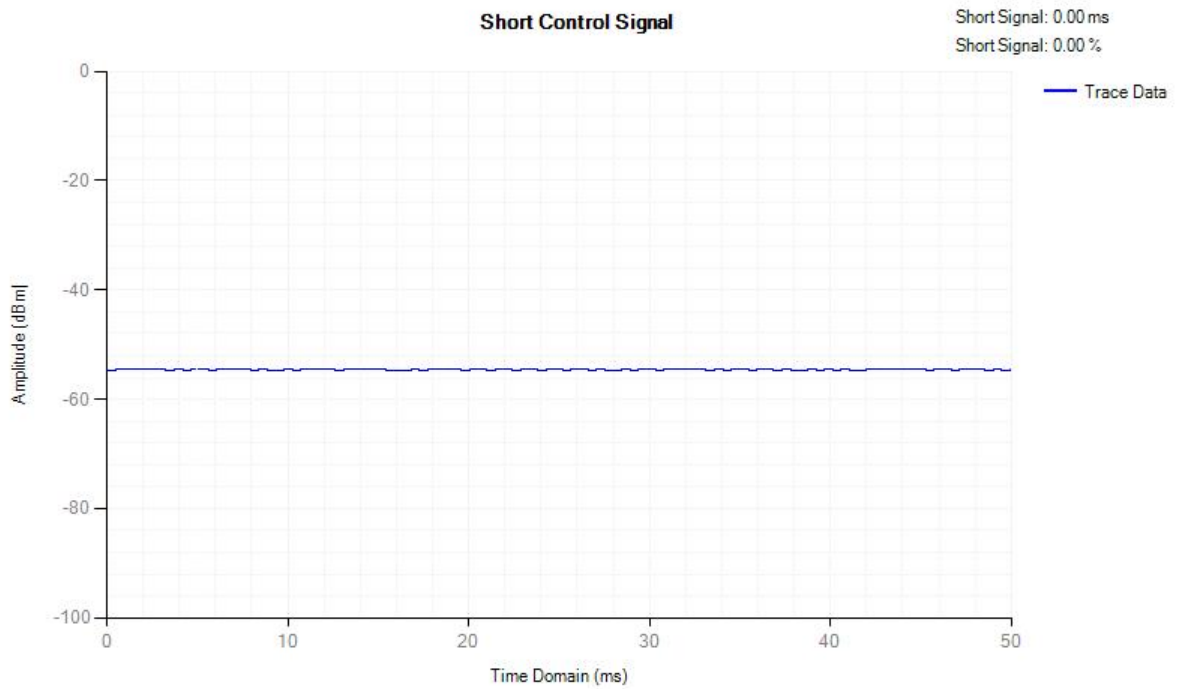

Adaptivity NVNT ac20 5180MHz LTE

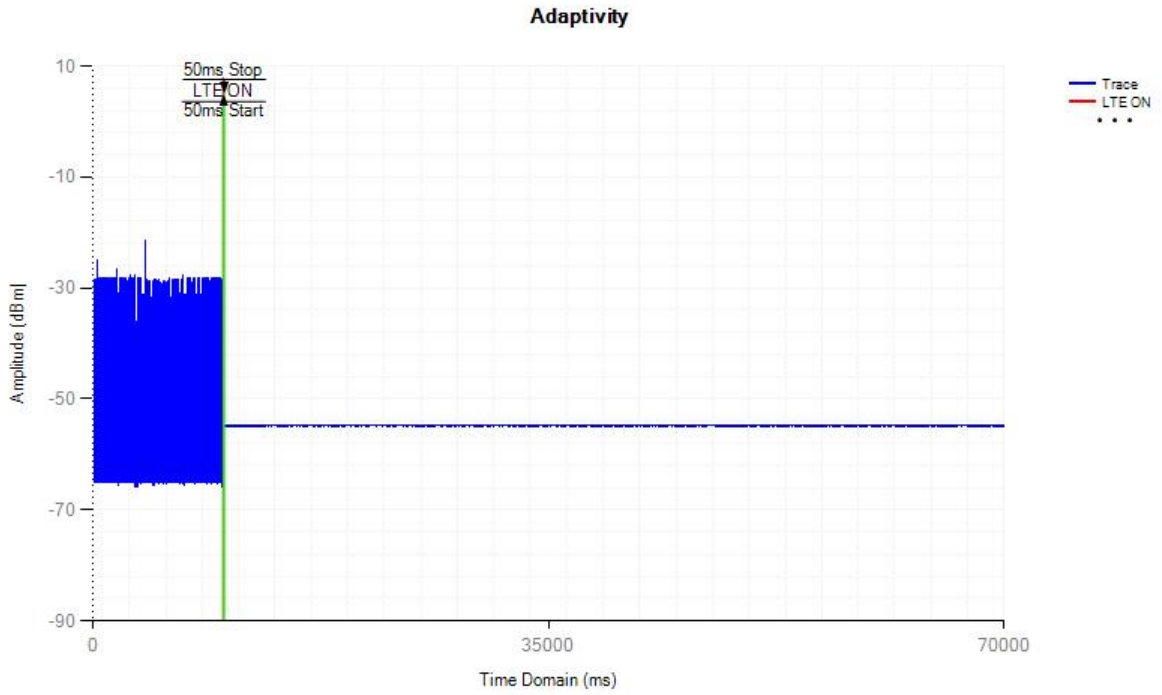

Control Signal NVNT ac20 5180MHz LTE

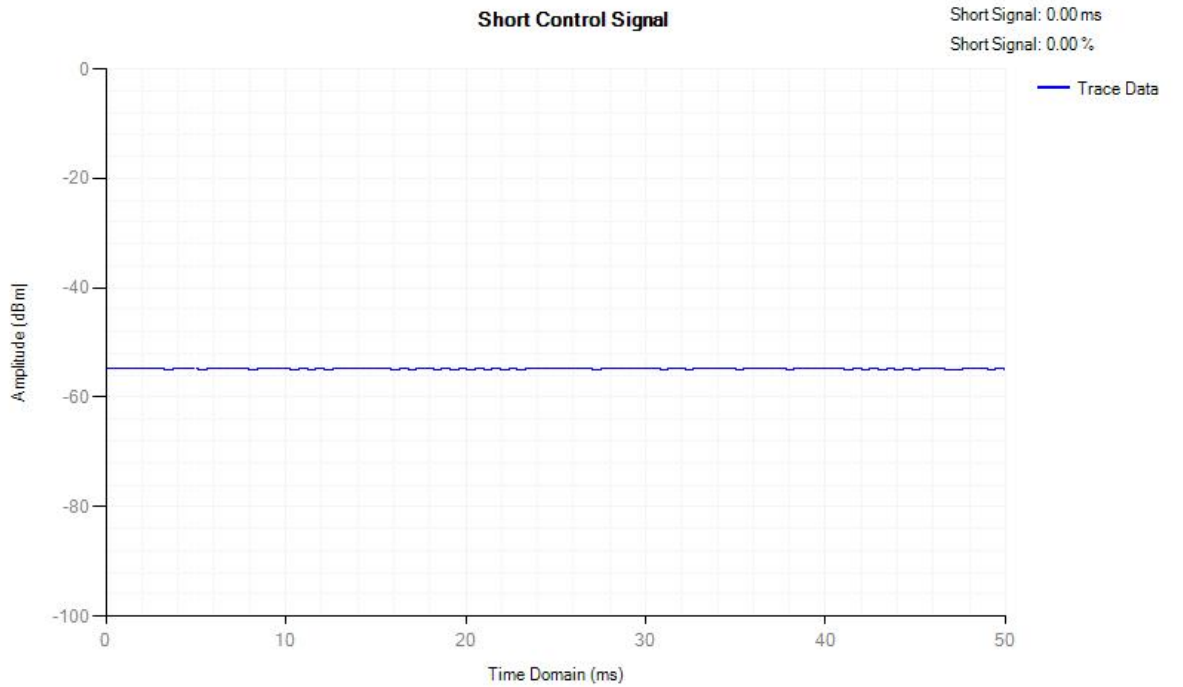

Adaptivity NVNT ac20 5180MHz OFDM

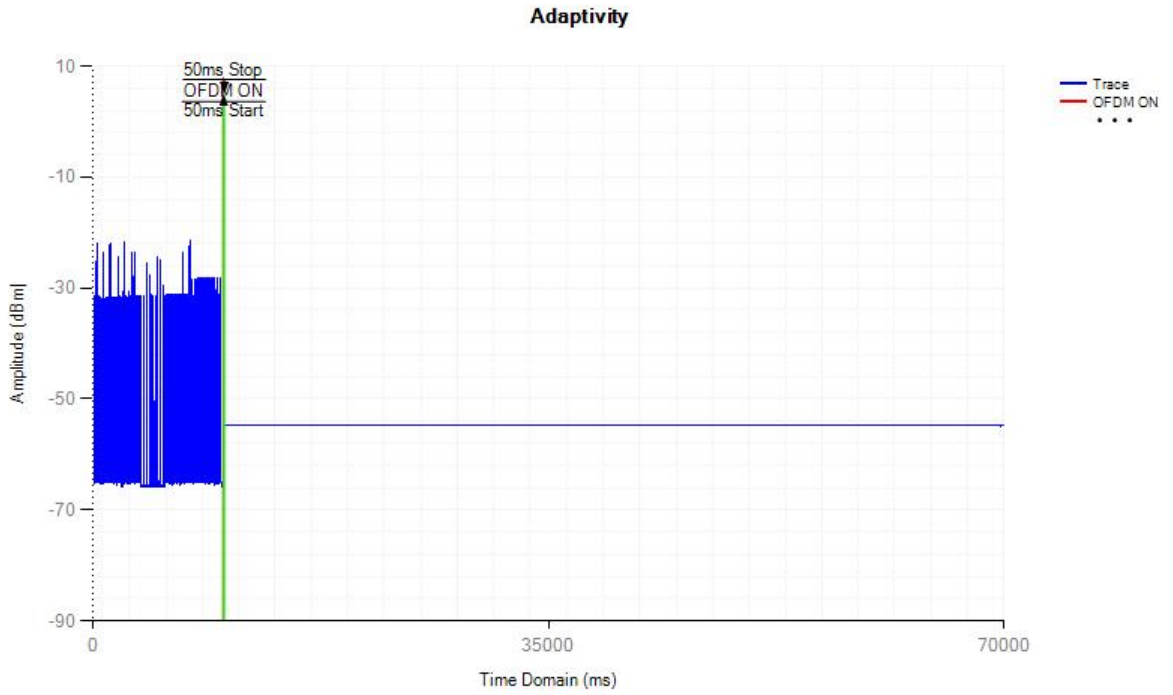

Control Signal NVNT ac20 5180MHz OFDM

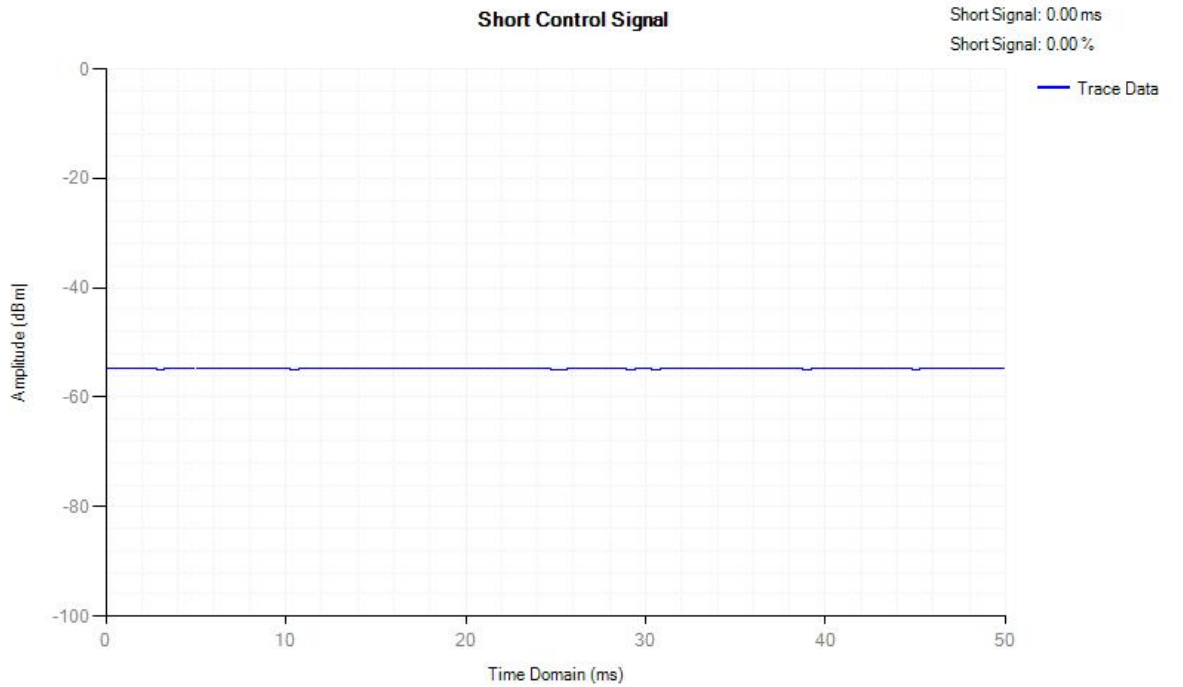

Adaptivity NVNT ac20 5240MHz AWGN

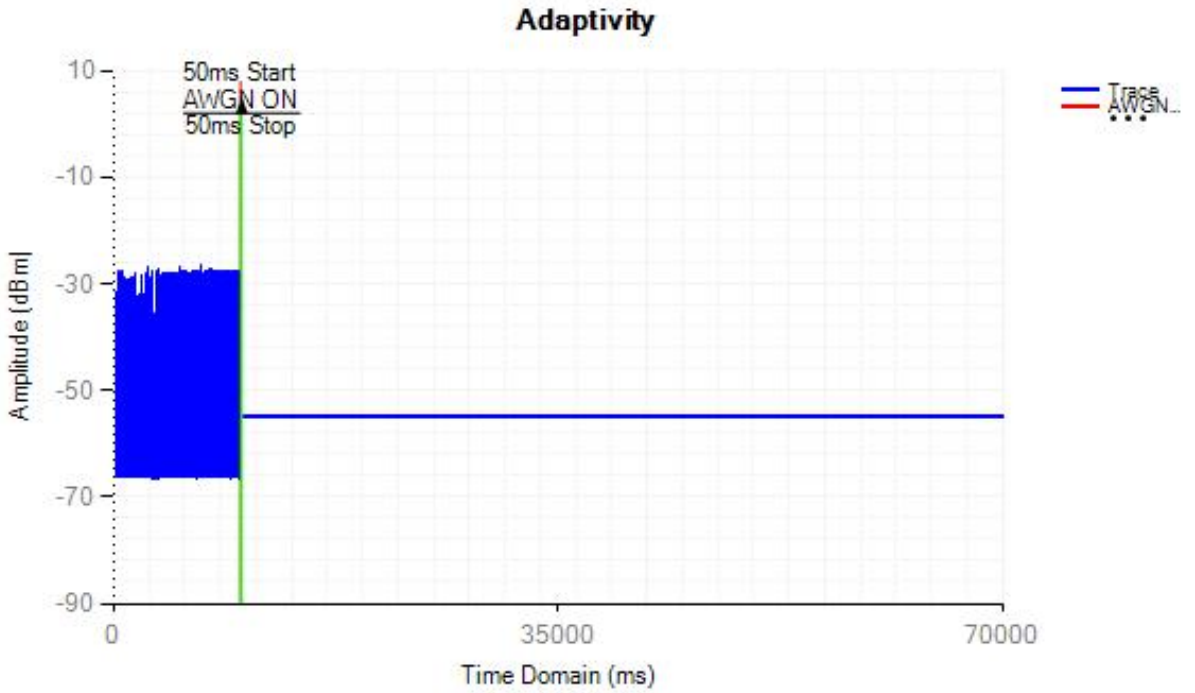

Control Signal NVNT ac20 5240MHz AWGN

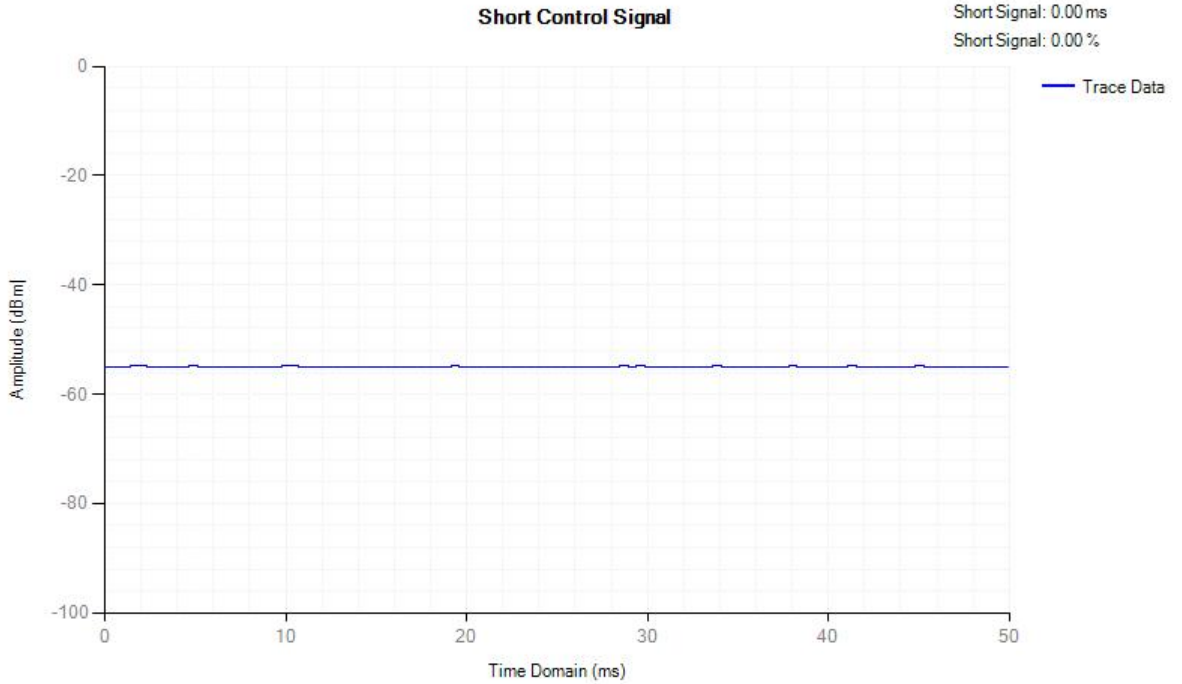

Adaptivity NVNT ac20 5240MHz LTE

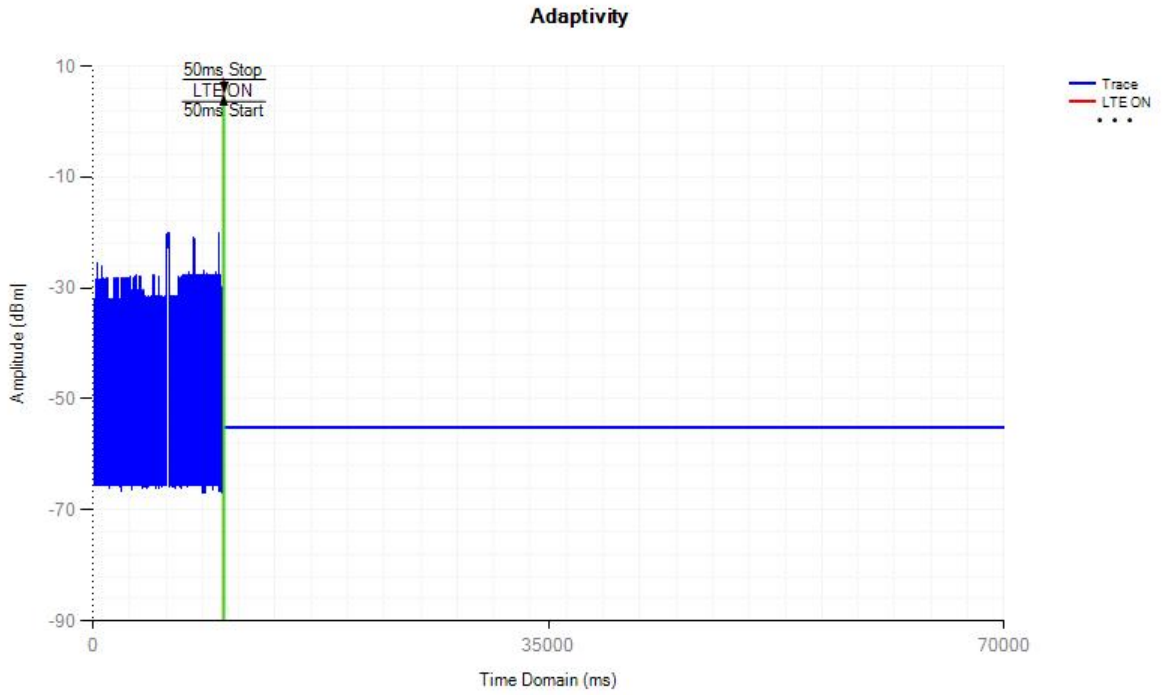

Control Signal NVNT ac20 5240MHz LTE

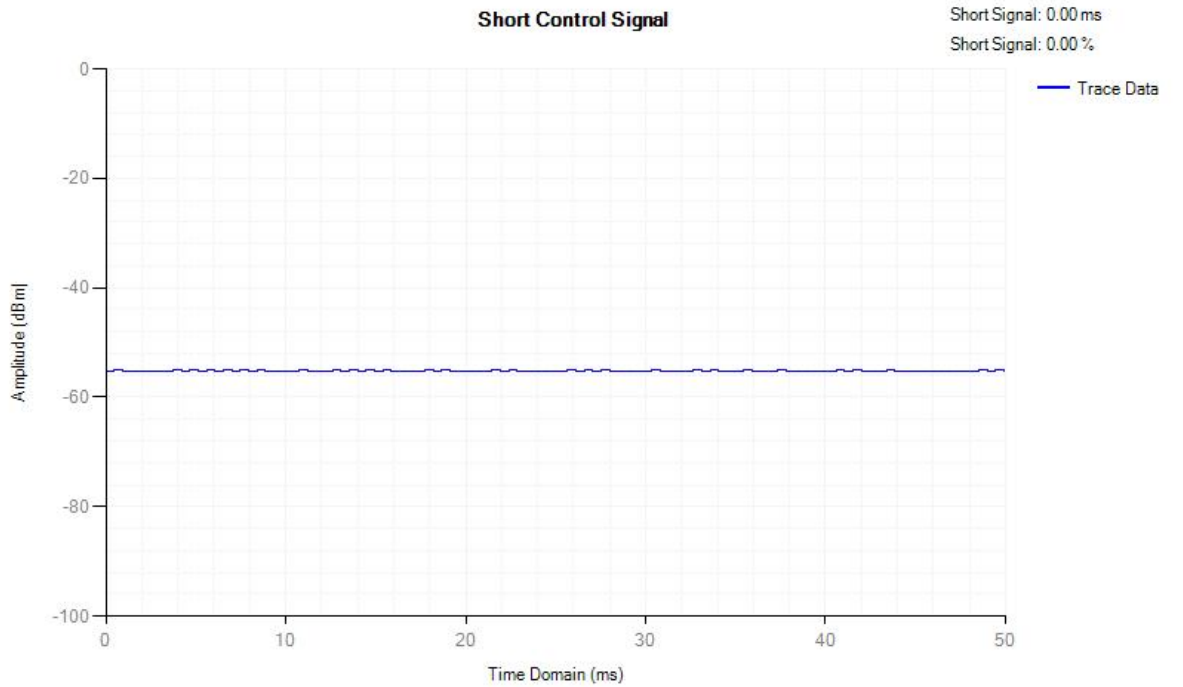

Adaptivity NVNT ac20 5240MHz OFDM

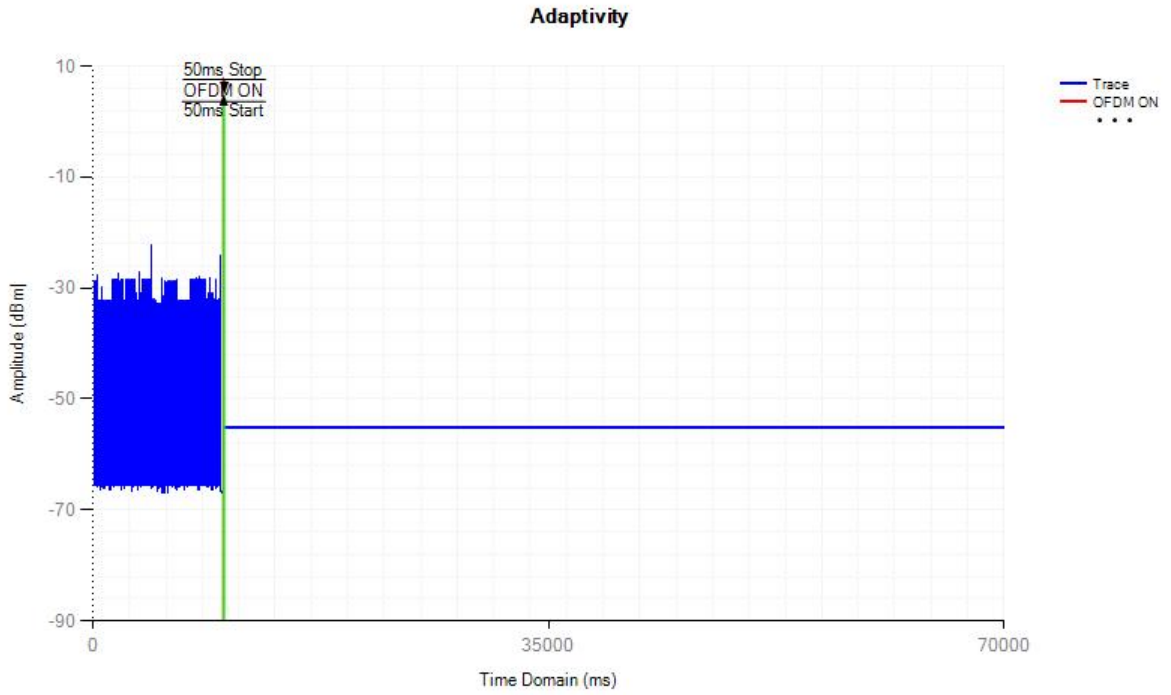

Control Signal NVNT ac20 5240MHz OFDM

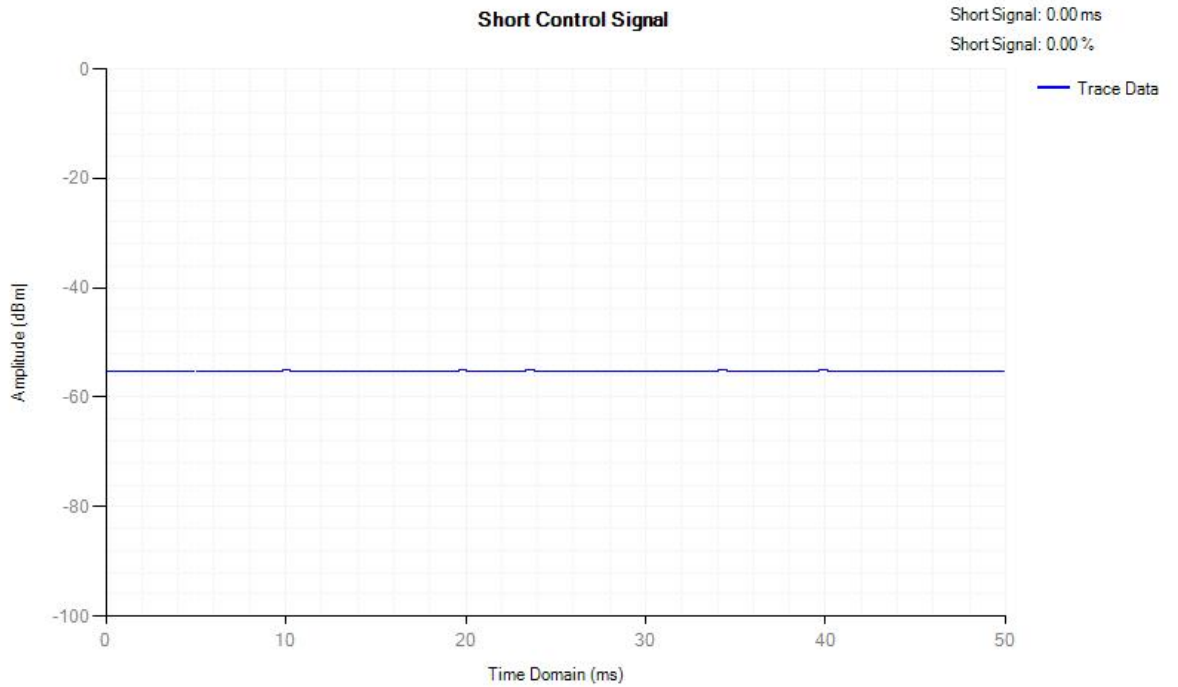

Adaptivity NVNT n20 5180MHz AWGN

Adaptivity

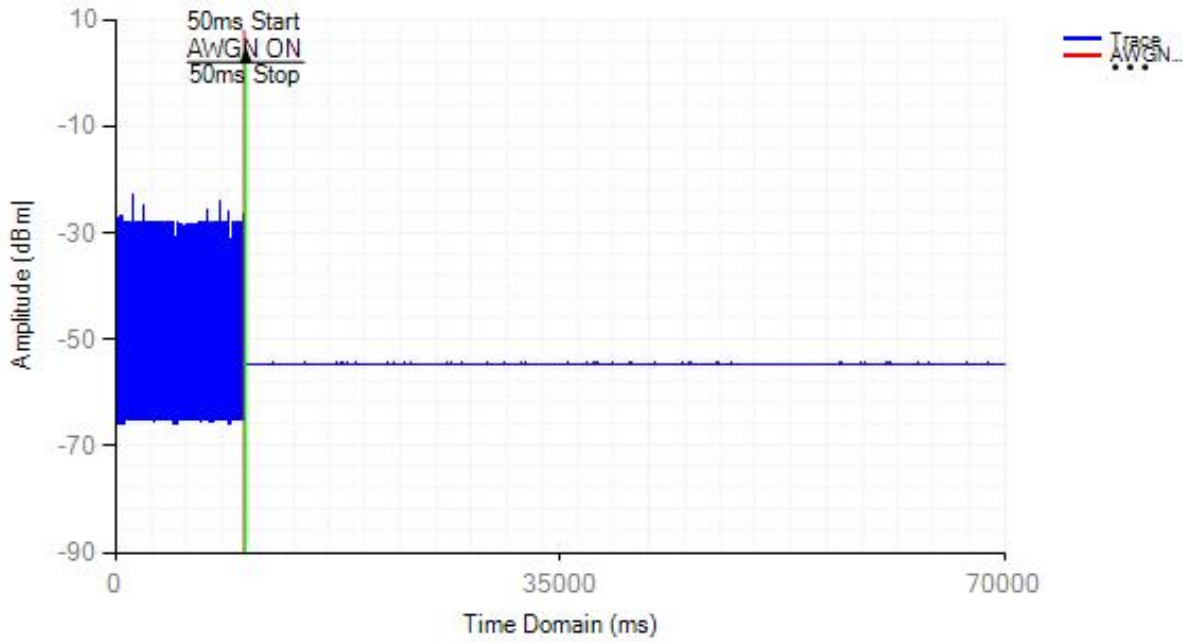

Control Signal NVNT n20 5180MHz AWGN

Short Control Signal

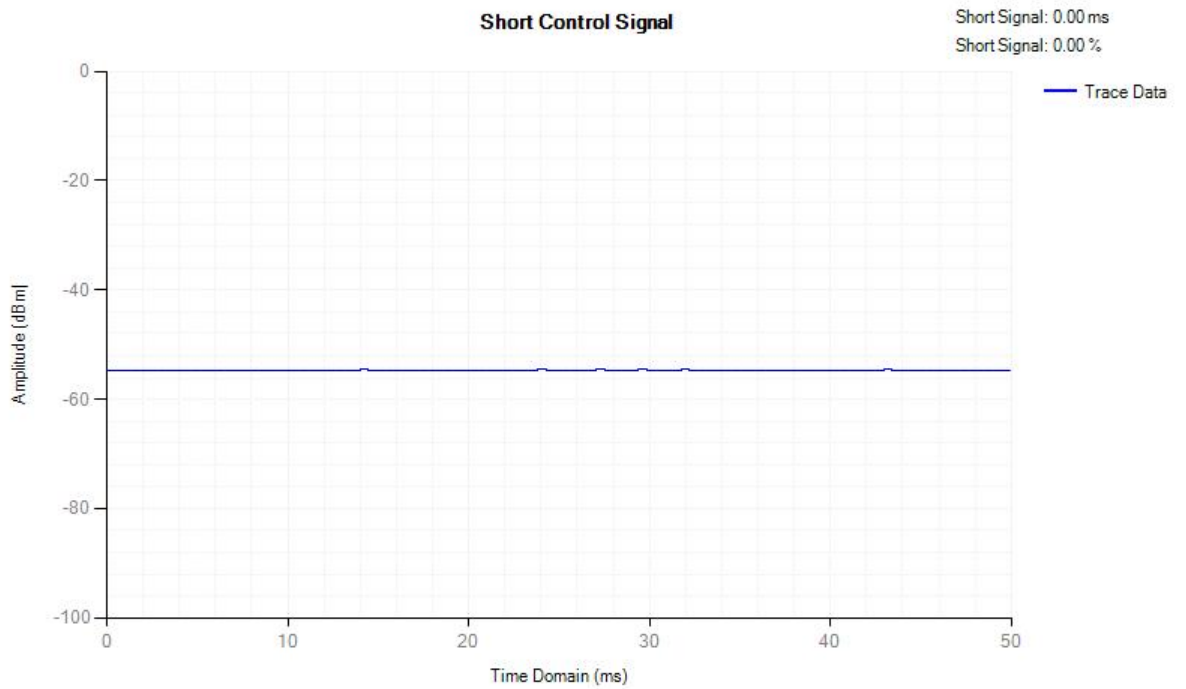

Adaptivity NVNT n20 5180MHz LTE

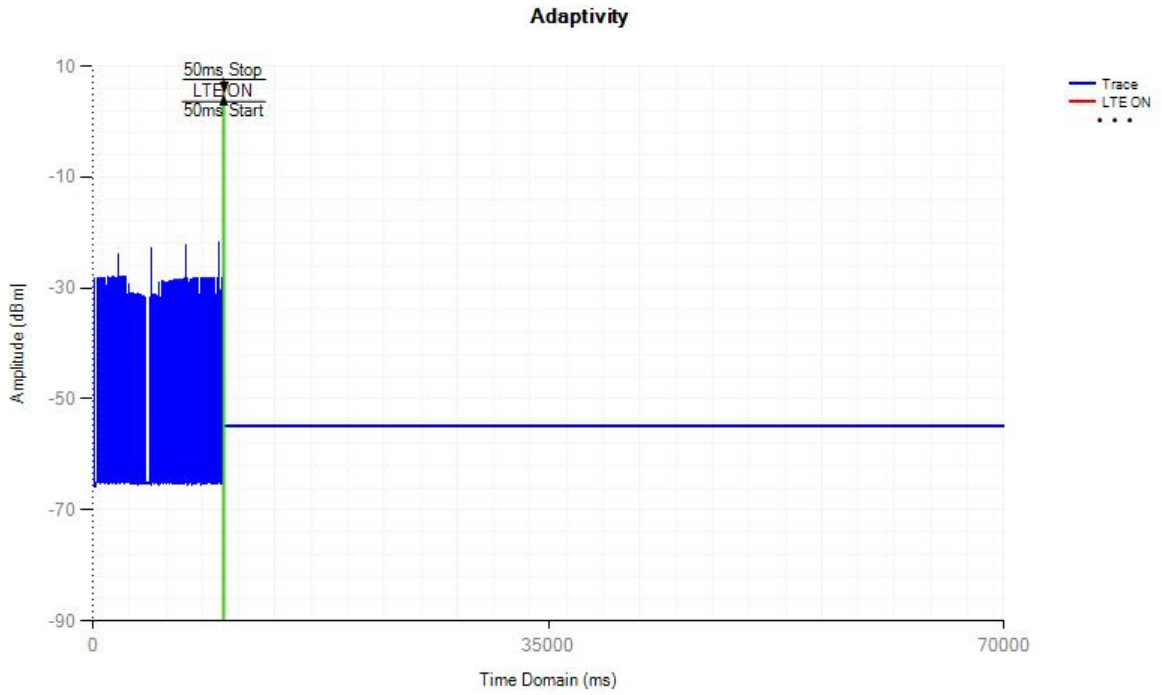

Control Signal NVNT n20 5180MHz LTE

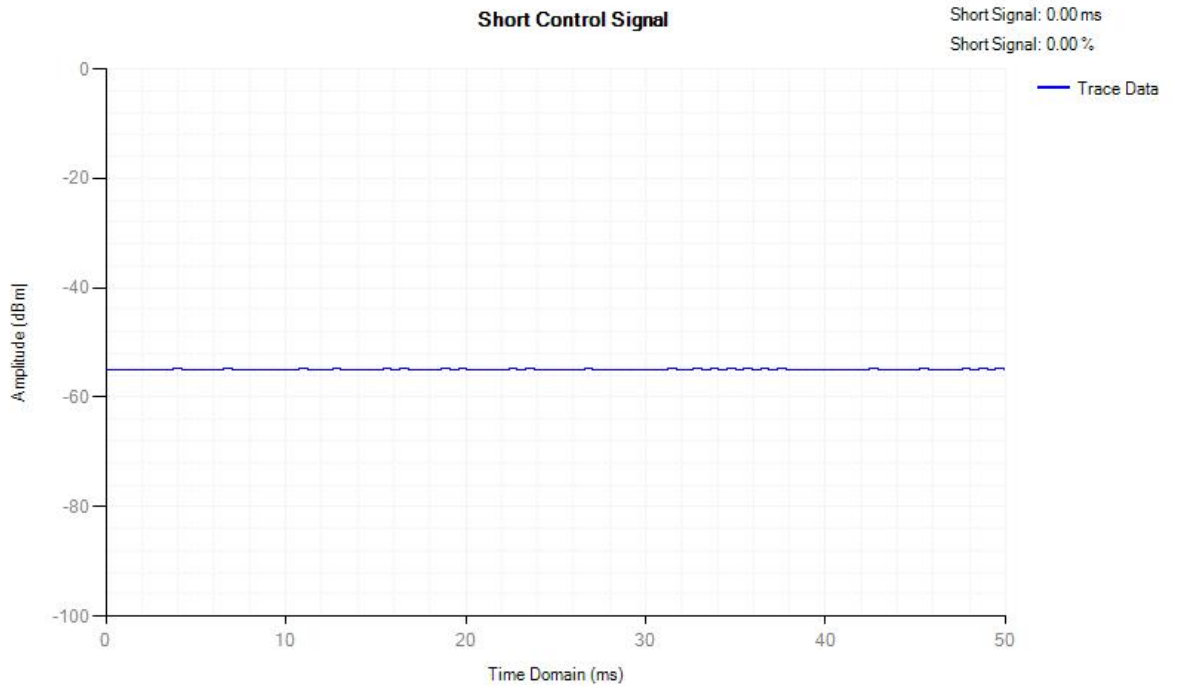

Adaptivity NVNT n20 5180MHz OFDM

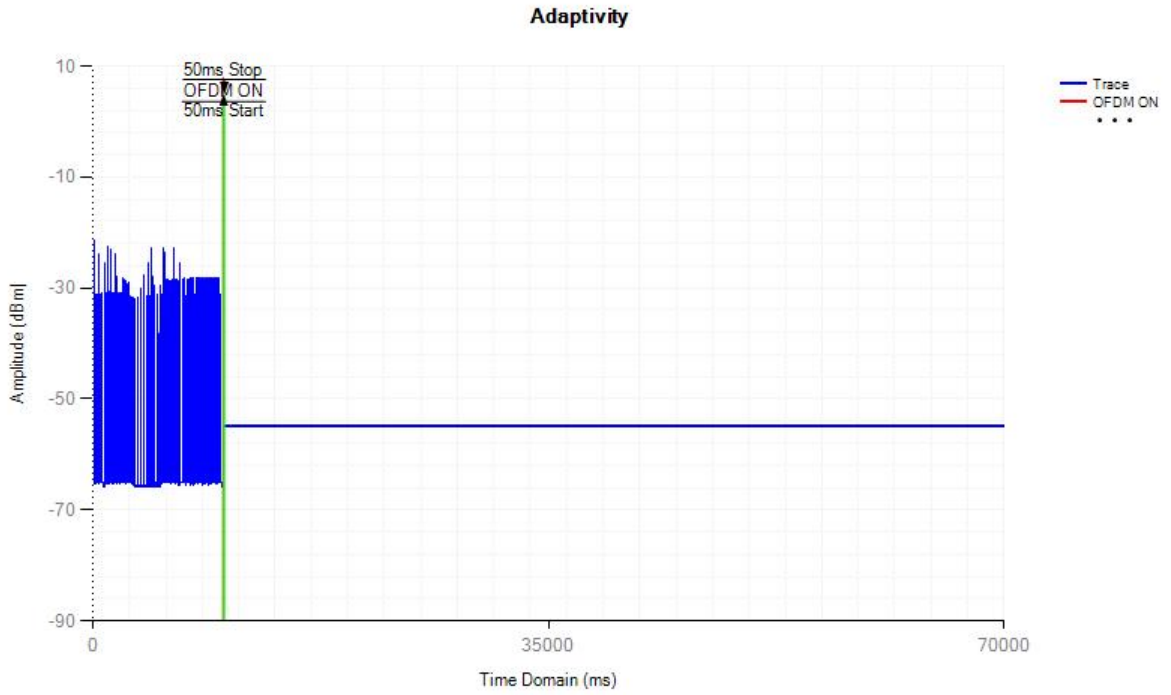

Control Signal NVNT n20 5180MHz OFDM

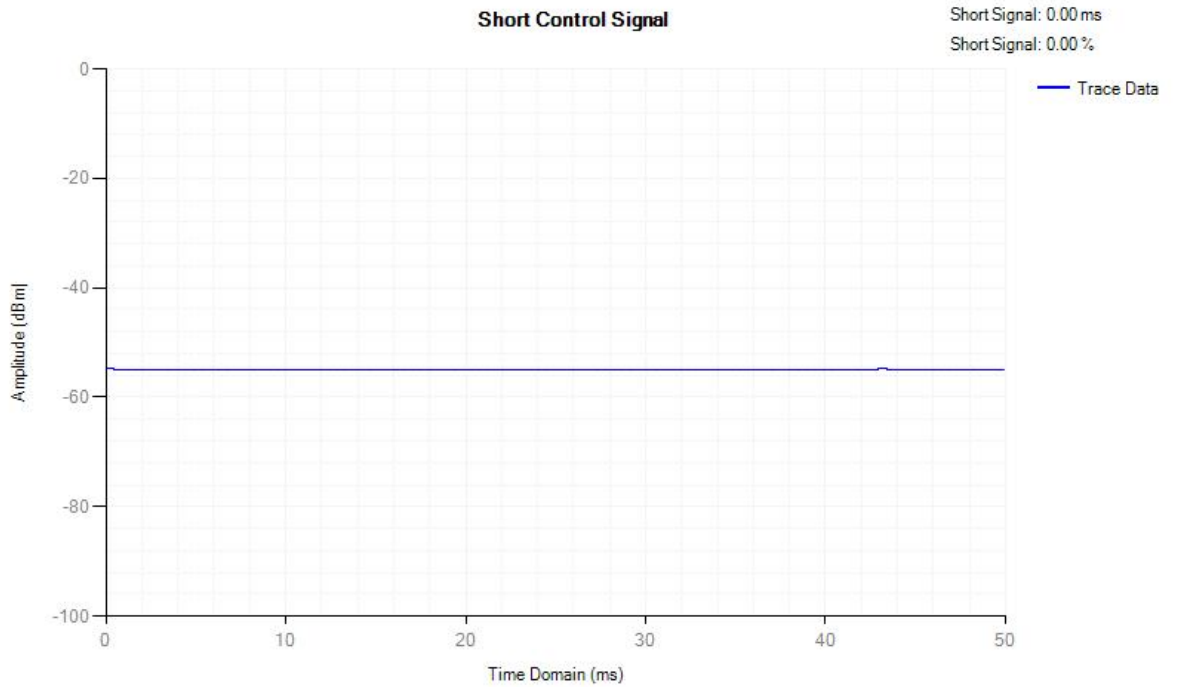

Adaptivity NVNT n20 5240MHz AWGN

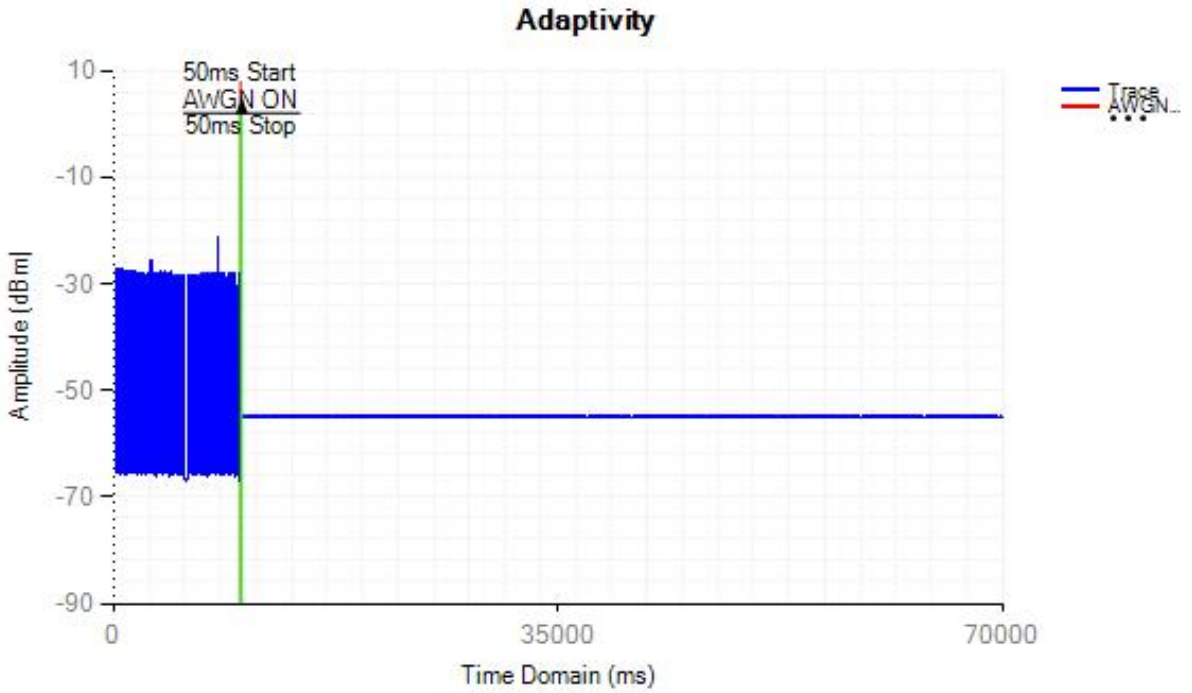

Control Signal NVNT n20 5240MHz AWGN

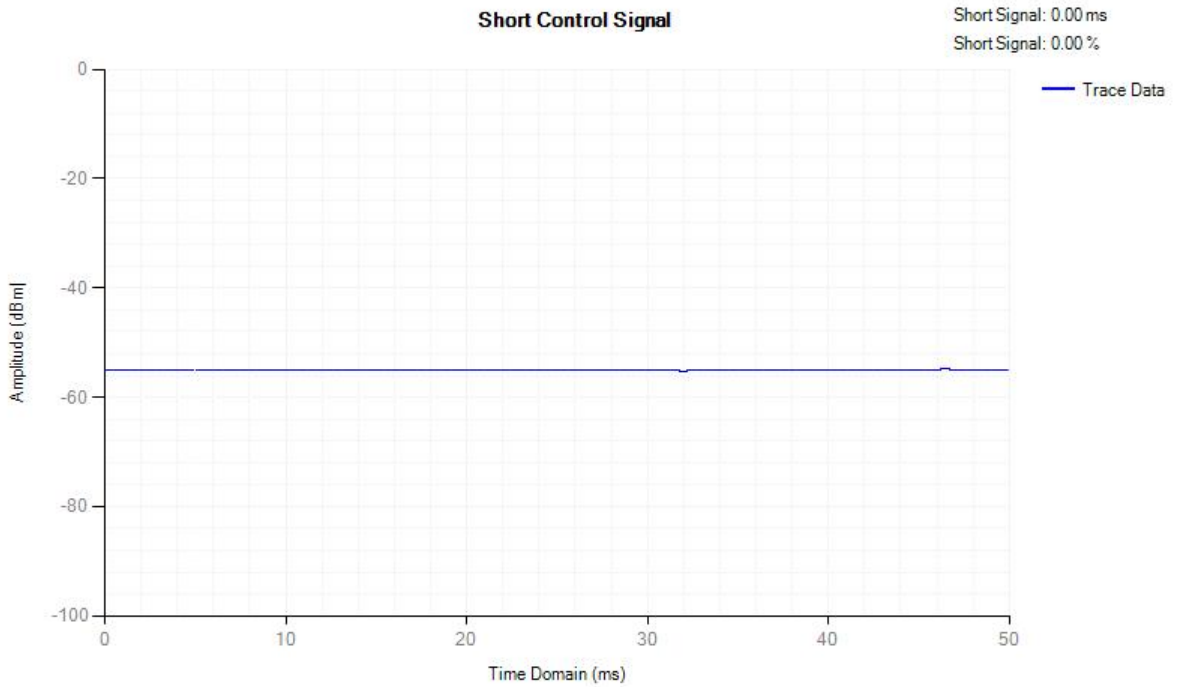

Adaptivity NVNT n20 5240MHz LTE

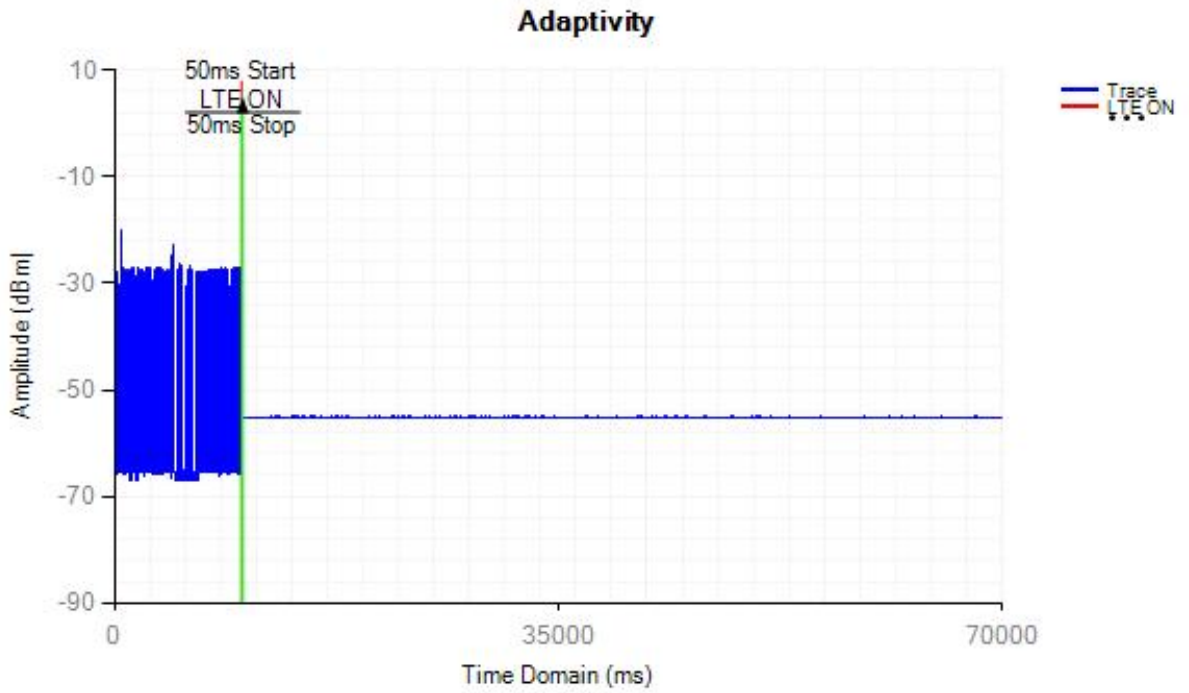

Control Signal NVNT n20 5240MHz LTE

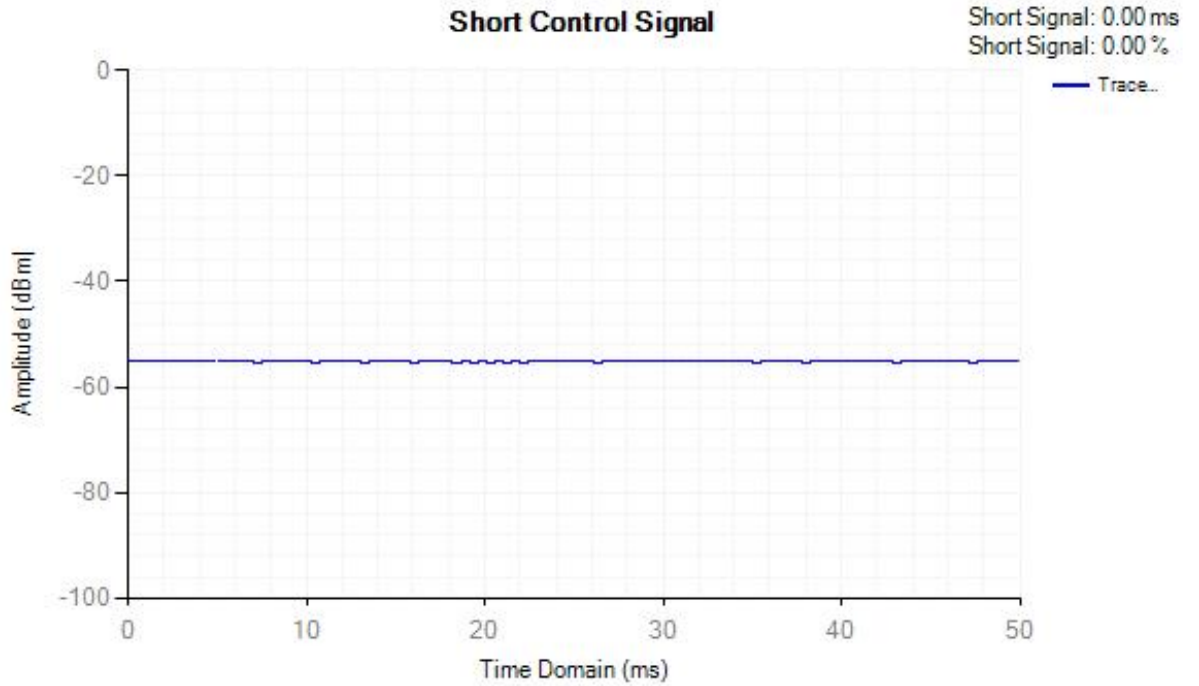

Adaptivity NVNT n20 5240MHz OFDM

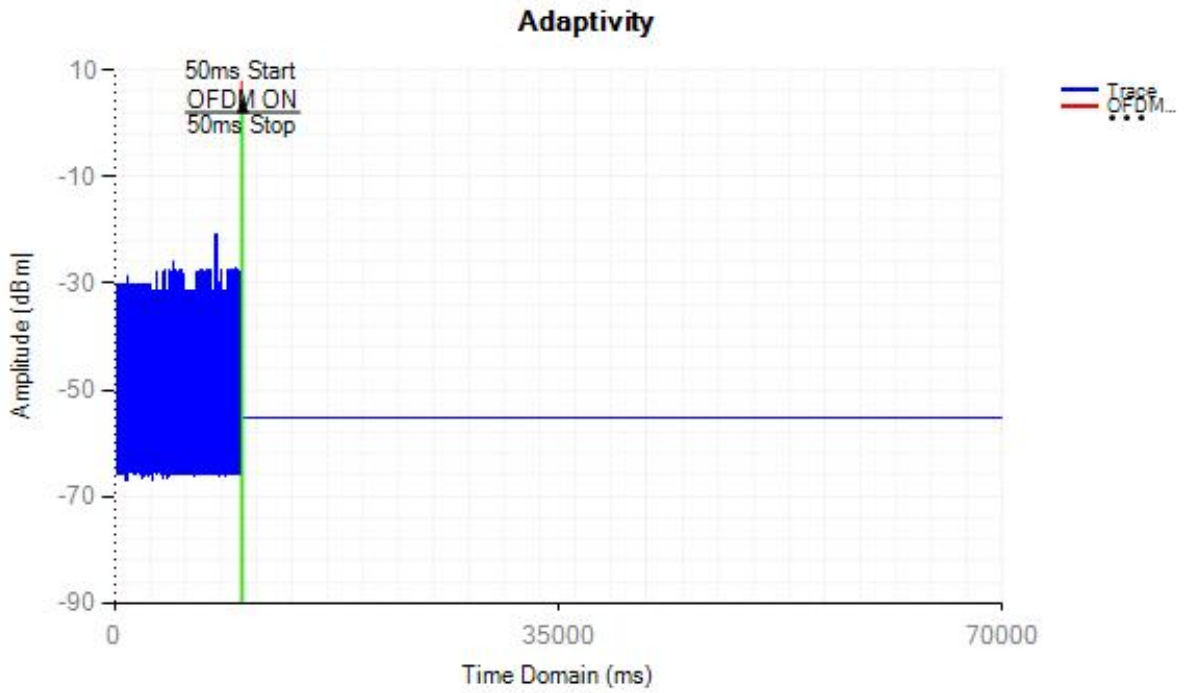

Control Signal NVNT n20 5240MHz OFDM

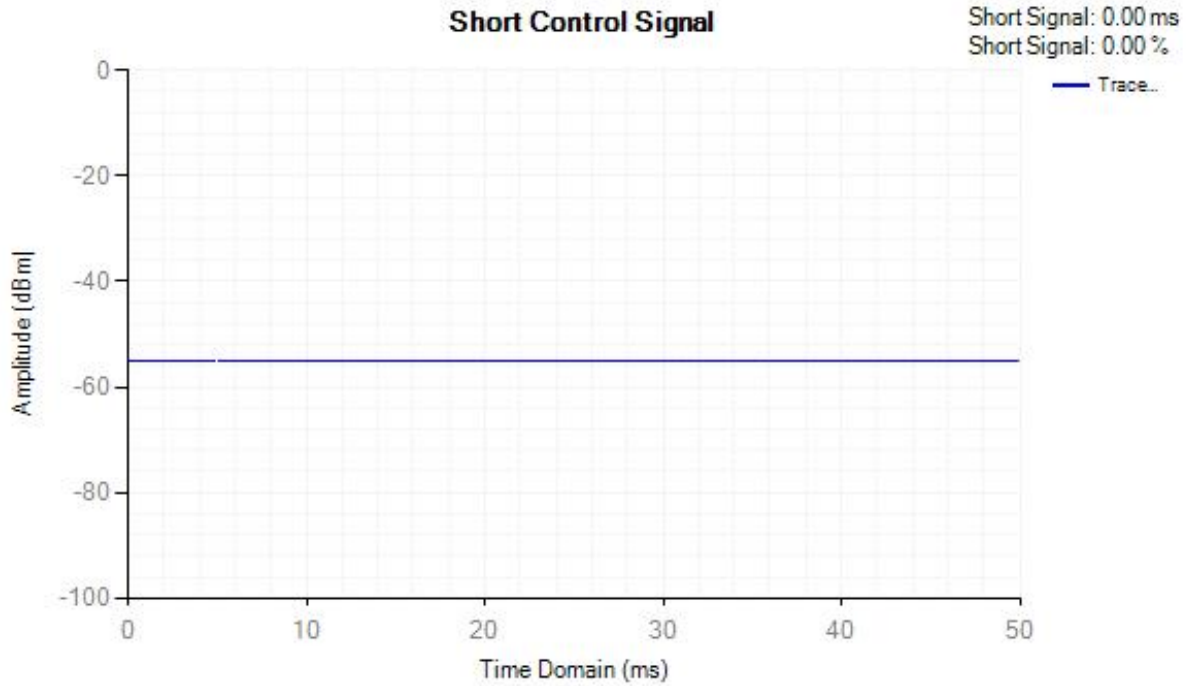

Adaptivity COT Channel Occupancy Time

Condition	Mode	Frequency (MHz)	Antenna	Priority Class	Max COT (ms)	Limit COT (ms)	Min Idle Time (ms)	Limit Idle Time (ms)	Verdict
NVNT	a	5180	Ant1	2	0.163	<=6	0.043	>0.027	Pass
NVNT	a	5240	Ant1	2	0.227	<=6	0.043	>0.027	Pass
NVNT	ac20	5180	Ant1	2	4.62	<=6	0.04	>0.027	Pass
NVNT	ac20	5240	Ant1	2	1.18	<=6	0.04	>0.027	Pass
NVNT	n20	5180	Ant1	2	5.38	<=6	0.04	>0.027	Pass
NVNT	n20	5240	Ant1	2	4.62	<=6	0.04	>0.027	Pass

COT NVNT a 5180MHz

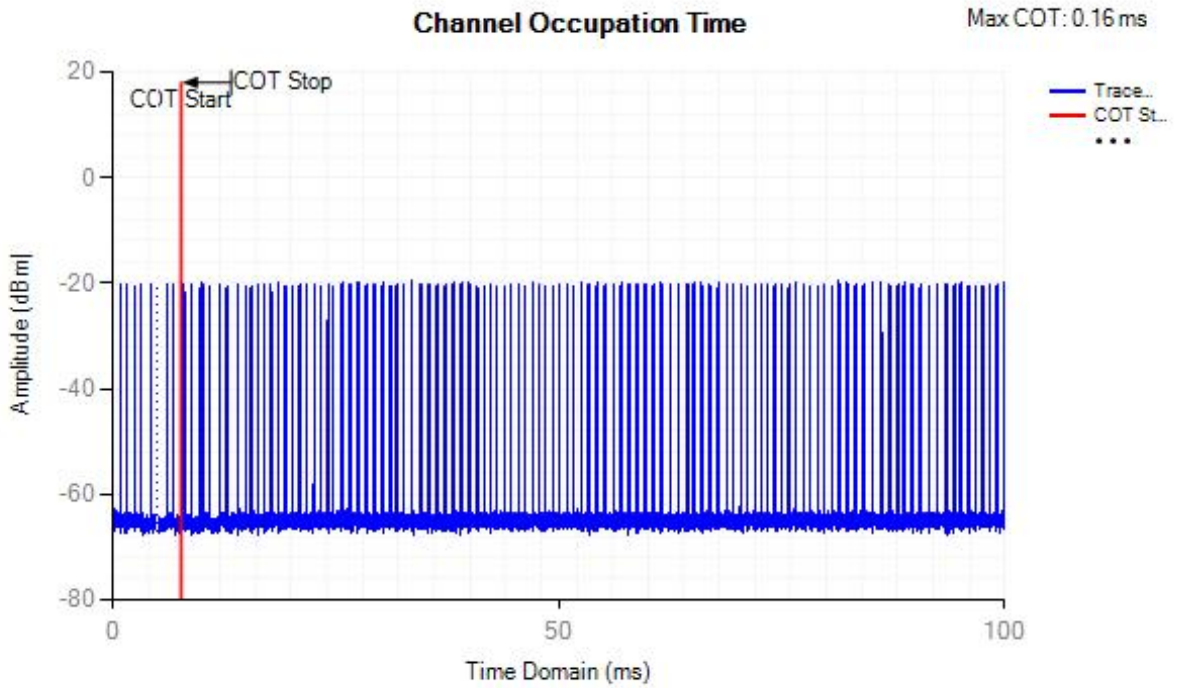



COT NVNT a 5240MHz

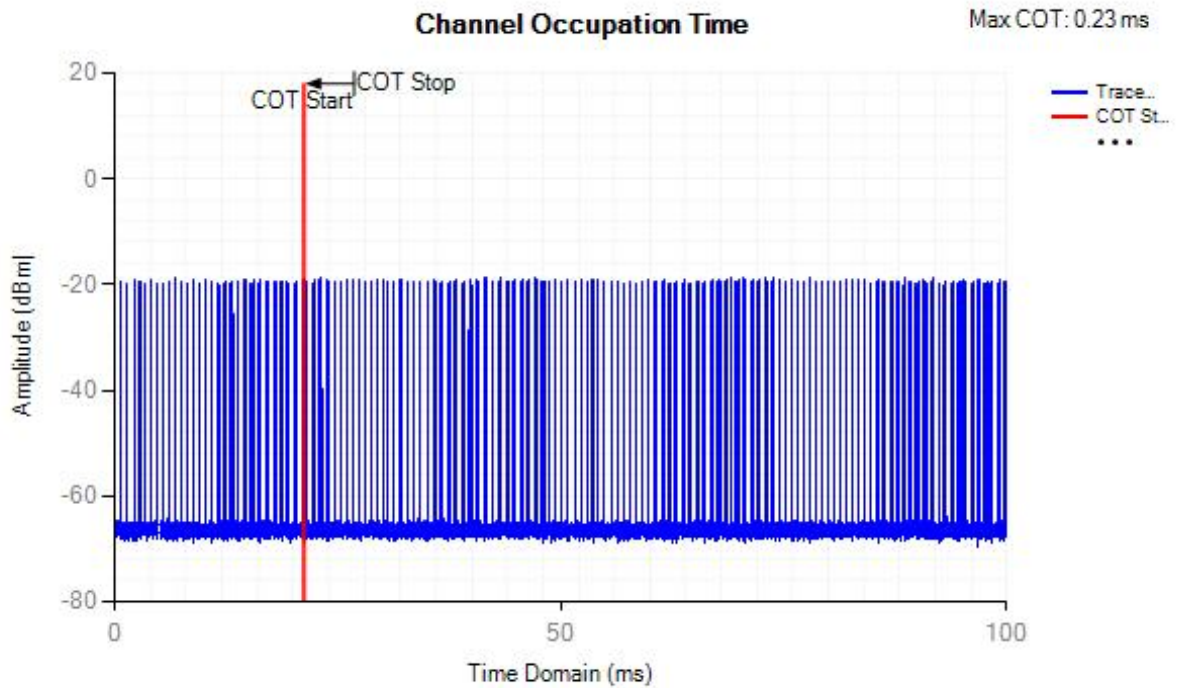

Channel Occupation Time

Min Idle Time: 0.04 ms

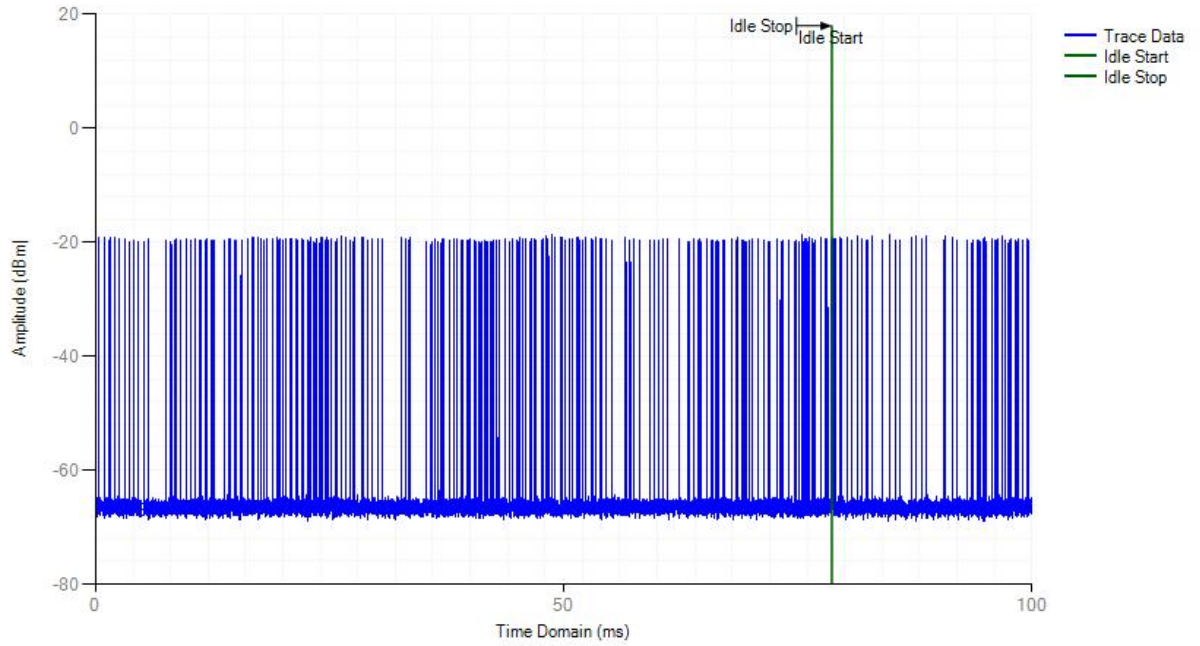

COT NVNT ac20 5180MHz

Channel Occupation Time

Max COT: 4.62 ms

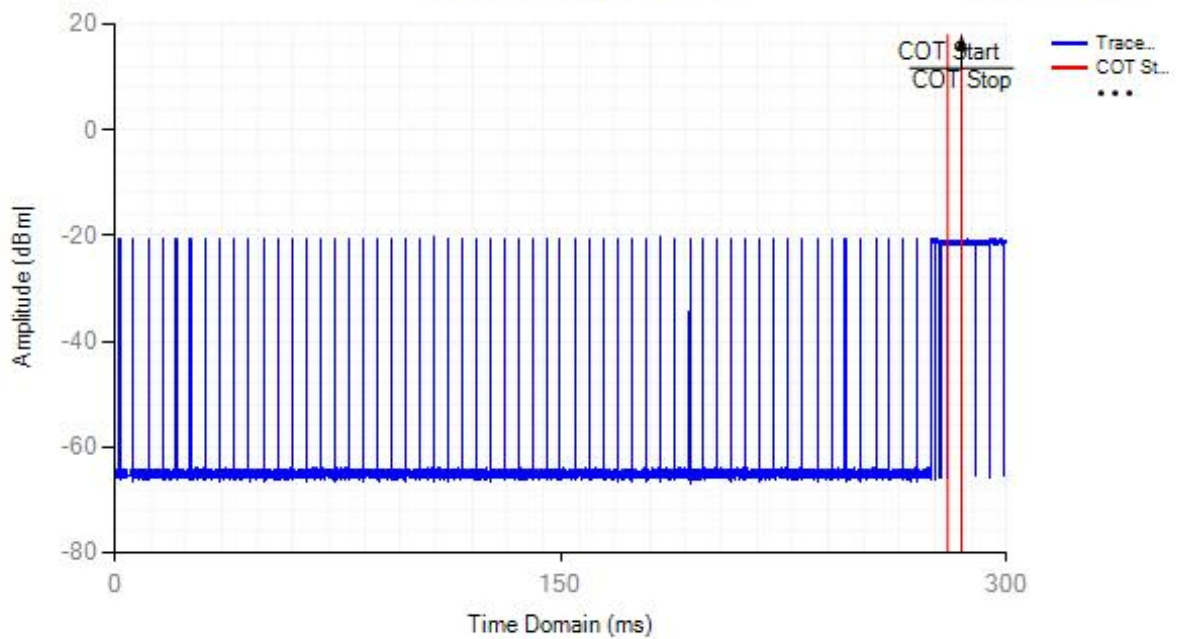

Channel Occupation Time

Min Idle Time: 0.04 ms

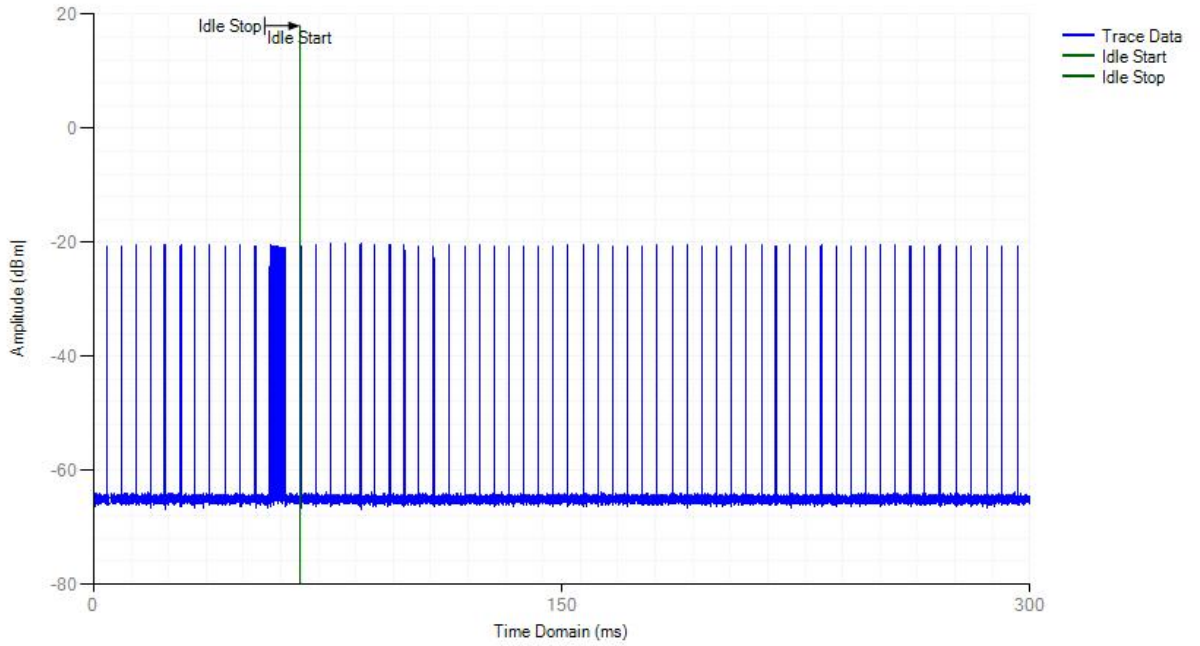

COT NVNT ac20 5240MHz

Channel Occupation Time

Max COT: 1.18 ms

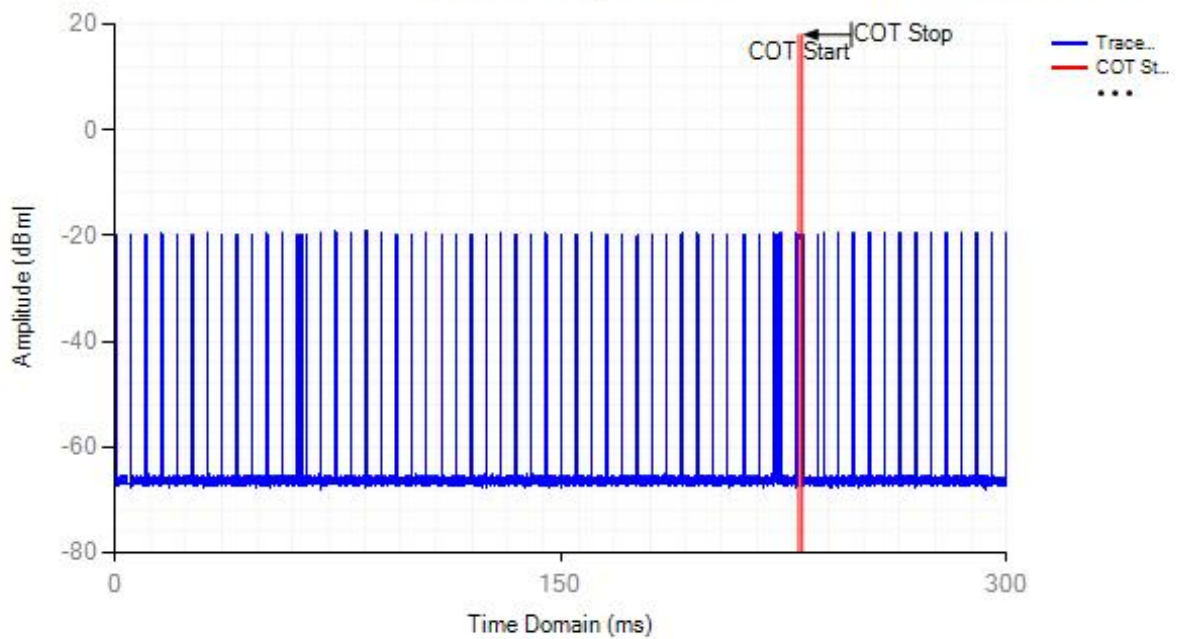

Channel Occupation Time

Min Idle Time: 0.04 ms

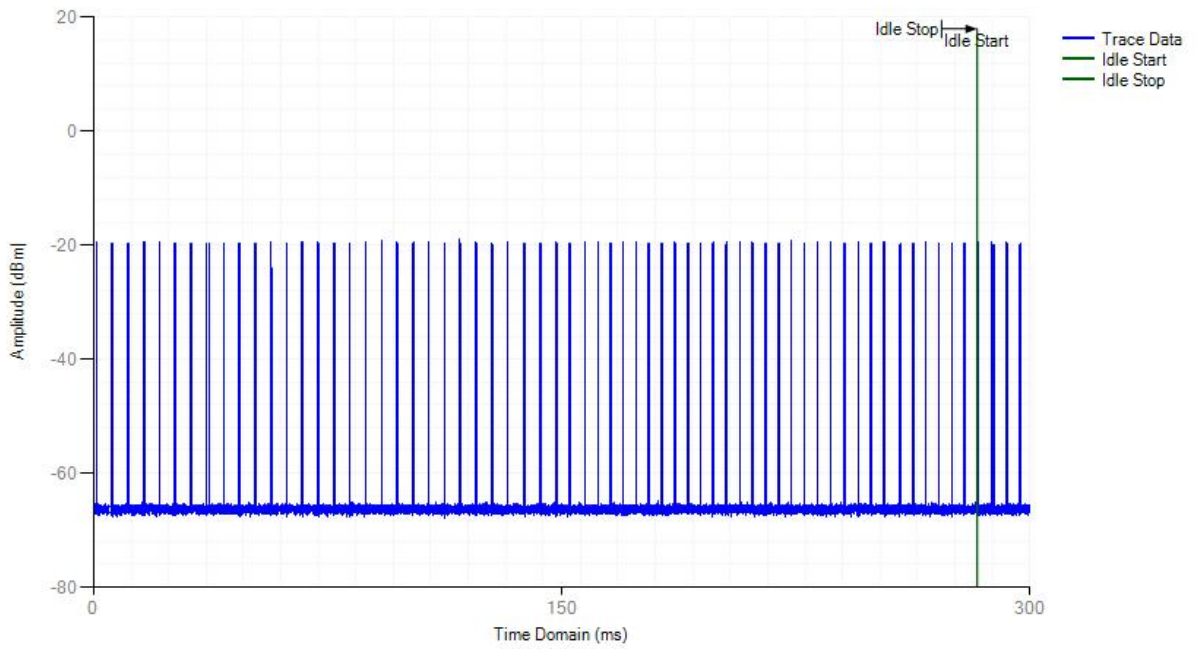

COT NVNT n20 5180MHz

Channel Occupation Time

Max COT: 5.38 ms

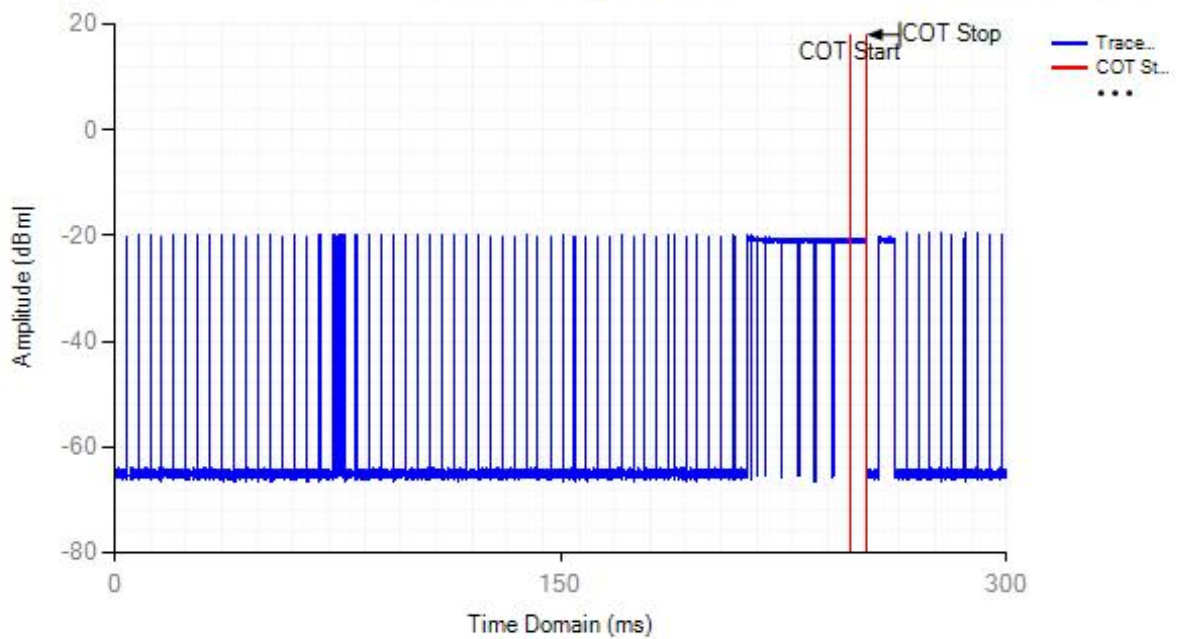

Channel Occupation Time

Min Idle Time: 0.04 ms

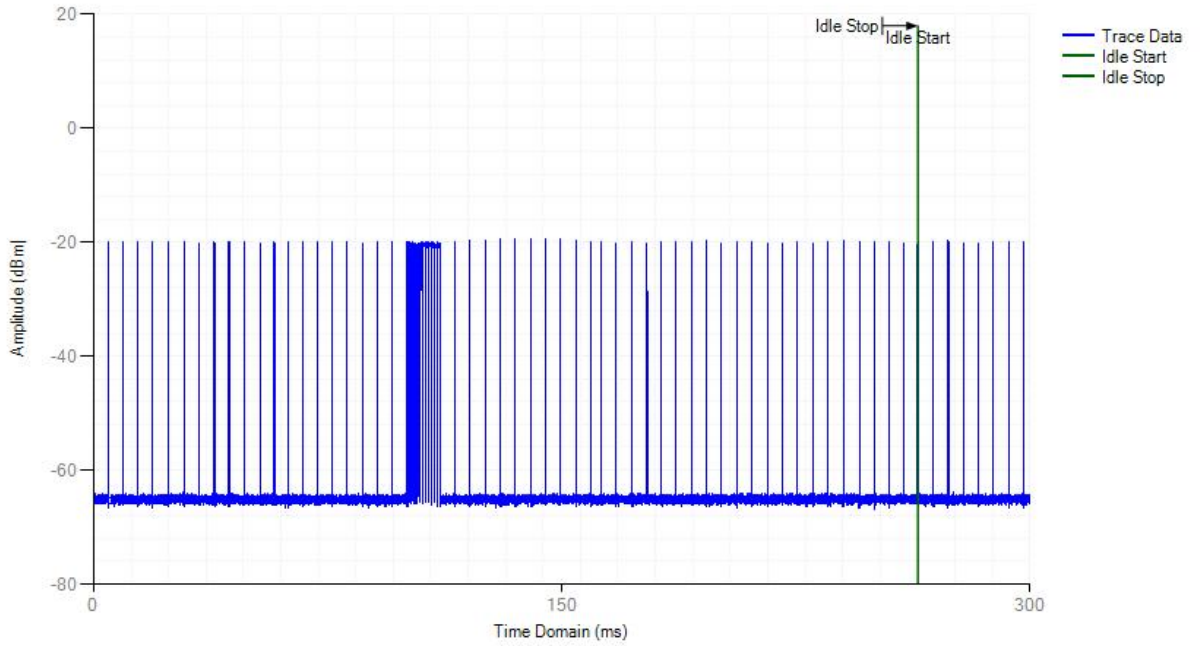

COT NVNT n20 5240MHz

Channel Occupation Time

Max COT: 4.62 ms

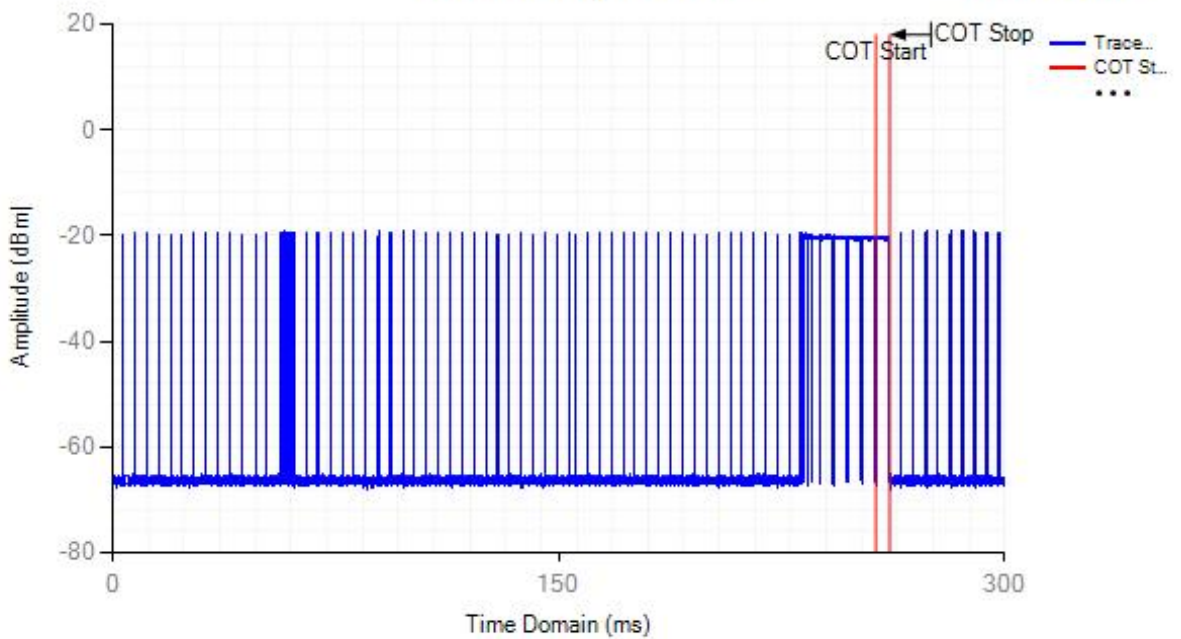

Channel Occupation Time

Min Idle Time: 0.04 ms

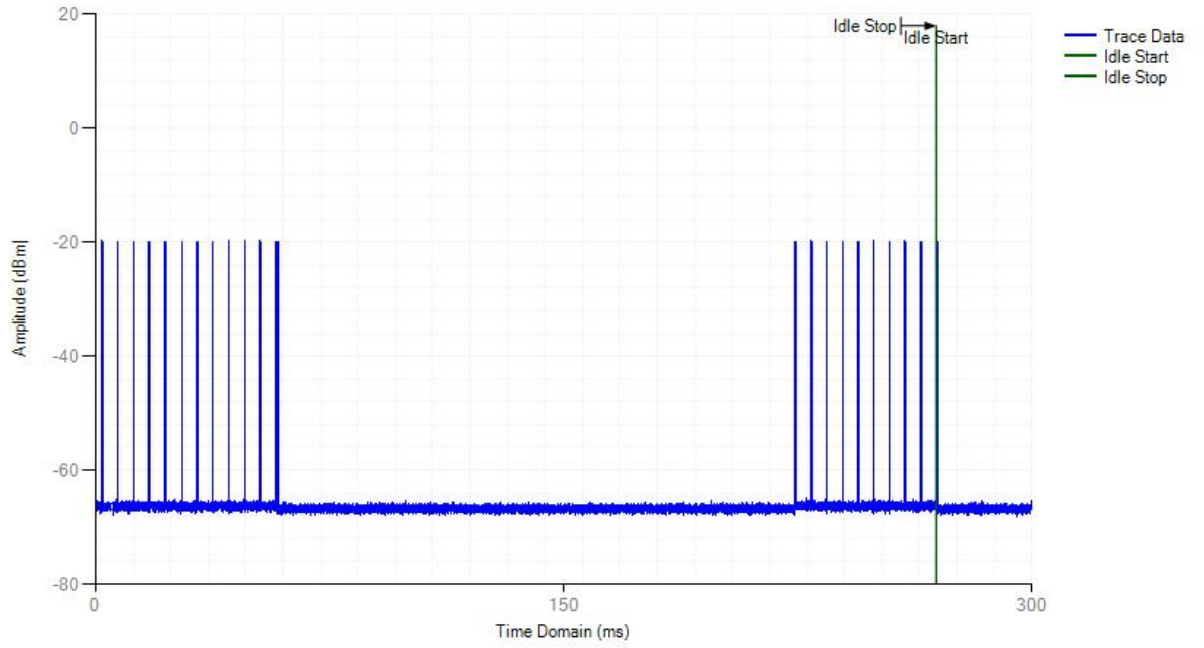

Idle Period Probability

Condition	Mode	Frequency (MHz)	Antenna	Priority Class	Bn	H(Bn)	Pn (%)	Limit (%)	Verdict
NVNT	a	5180	Ant1	2	0	58	0.57	5	Pass
NVNT	a	5180	Ant1	2	1	5	0.62	12	Pass
NVNT	a	5180	Ant1	2	2	0	0.62	18.25	Pass
NVNT	a	5180	Ant1	2	3	0	0.62	24.5	Pass
NVNT	a	5180	Ant1	2	4	2	0.64	30.75	Pass
NVNT	a	5180	Ant1	2	5	0	0.64	37	Pass
NVNT	a	5180	Ant1	2	6	5	0.69	43.25	Pass
NVNT	a	5180	Ant1	2	7	1695	17.36	49.5	Pass
NVNT	a	5180	Ant1	2	8	706	24.3	55.75	Pass
NVNT	a	5180	Ant1	2	9	928	33.43	62	Pass
NVNT	a	5180	Ant1	2	10	2	33.44	68.25	Pass
NVNT	a	5180	Ant1	2	11	0	33.44	74.5	Pass
NVNT	a	5180	Ant1	2	12	1	33.45	80.75	Pass
NVNT	a	5180	Ant1	2	13	0	33.45	87	Pass
NVNT	a	5180	Ant1	2	14	0	33.45	93.25	Pass
NVNT	a	5180	Ant1	2	15	2	33.47	99.5	Pass
NVNT	a	5180	Ant1	2	16	6765	100	100	Pass
NVNT	a	5240	Ant1	2	0	49	0.49	5	Pass
NVNT	a	5240	Ant1	2	1	3	0.52	12	Pass
NVNT	a	5240	Ant1	2	2	4	0.56	18.25	Pass
NVNT	a	5240	Ant1	2	3	4	0.6	24.5	Pass
NVNT	a	5240	Ant1	2	4	0	0.6	30.75	Pass
NVNT	a	5240	Ant1	2	5	6	0.66	37	Pass
NVNT	a	5240	Ant1	2	6	1	0.67	43.25	Pass
NVNT	a	5240	Ant1	2	7	4	0.71	49.5	Pass
NVNT	a	5240	Ant1	2	8	69	1.4	55.75	Pass
NVNT	a	5240	Ant1	2	9	281	4.2	62	Pass
NVNT	a	5240	Ant1	2	10	191	6.1	68.25	Pass
NVNT	a	5240	Ant1	2	11	88	6.98	74.5	Pass
NVNT	a	5240	Ant1	2	12	194	8.92	80.75	Pass
NVNT	a	5240	Ant1	2	13	316	12.07	87	Pass
NVNT	a	5240	Ant1	2	14	205	14.11	93.25	Pass
NVNT	a	5240	Ant1	2	15	82	14.93	99.5	Pass
NVNT	a	5240	Ant1	2	16	8531	100	100	Pass
NVNT	ac20	5180	Ant1	2	0	100	0.99	5	Pass
NVNT	ac20	5180	Ant1	2	1	3	1.02	12	Pass
NVNT	ac20	5180	Ant1	2	2	1	1.03	18.25	Pass
NVNT	ac20	5180	Ant1	2	3	13	1.16	24.5	Pass

NVNT	ac20	5180	Ant1	2	4	5	1.21	30.75	Pass
NVNT	ac20	5180	Ant1	2	5	3	1.24	37	Pass
NVNT	ac20	5180	Ant1	2	6	14	1.38	43.25	Pass
NVNT	ac20	5180	Ant1	2	7	21	1.58	49.5	Pass
NVNT	ac20	5180	Ant1	2	8	157	3.14	55.75	Pass
NVNT	ac20	5180	Ant1	2	9	325	6.36	62	Pass
NVNT	ac20	5180	Ant1	2	10	289	9.22	68.25	Pass
NVNT	ac20	5180	Ant1	2	11	128	10.48	74.5	Pass
NVNT	ac20	5180	Ant1	2	12	168	12.15	80.75	Pass
NVNT	ac20	5180	Ant1	2	13	293	15.05	87	Pass
NVNT	ac20	5180	Ant1	2	14	388	18.89	93.25	Pass
NVNT	ac20	5180	Ant1	2	15	292	21.78	99.5	Pass
NVNT	ac20	5180	Ant1	2	16	7901	100	100	Pass
NVNT	ac20	5240	Ant1	2	0	104	1.04	5	Pass
NVNT	ac20	5240	Ant1	2	1	5	1.09	12	Pass
NVNT	ac20	5240	Ant1	2	2	5	1.14	18.25	Pass
NVNT	ac20	5240	Ant1	2	3	9	1.23	24.5	Pass
NVNT	ac20	5240	Ant1	2	4	2	1.25	30.75	Pass
NVNT	ac20	5240	Ant1	2	5	0	1.25	37	Pass
NVNT	ac20	5240	Ant1	2	6	17	1.42	43.25	Pass
NVNT	ac20	5240	Ant1	2	7	19	1.61	49.5	Pass
NVNT	ac20	5240	Ant1	2	8	139	2.99	55.75	Pass
NVNT	ac20	5240	Ant1	2	9	228	5.26	62	Pass
NVNT	ac20	5240	Ant1	2	10	209	7.35	68.25	Pass
NVNT	ac20	5240	Ant1	2	11	92	8.27	74.5	Pass
NVNT	ac20	5240	Ant1	2	12	121	9.47	80.75	Pass
NVNT	ac20	5240	Ant1	2	13	276	12.22	87	Pass
NVNT	ac20	5240	Ant1	2	14	263	14.85	93.25	Pass
NVNT	ac20	5240	Ant1	2	15	222	17.06	99.5	Pass
NVNT	ac20	5240	Ant1	2	16	8318	100	100	Pass
NVNT	n20	5180	Ant1	2	0	105	1.05	5	Pass
NVNT	n20	5180	Ant1	2	1	13	1.18	12	Pass
NVNT	n20	5180	Ant1	2	2	2	1.2	18.25	Pass
NVNT	n20	5180	Ant1	2	3	10	1.3	24.5	Pass
NVNT	n20	5180	Ant1	2	4	6	1.36	30.75	Pass
NVNT	n20	5180	Ant1	2	5	8	1.44	37	Pass
NVNT	n20	5180	Ant1	2	6	24	1.68	43.25	Pass
NVNT	n20	5180	Ant1	2	7	36	2.04	49.5	Pass
NVNT	n20	5180	Ant1	2	8	126	3.3	55.75	Pass
NVNT	n20	5180	Ant1	2	9	397	7.26	62	Pass
NVNT	n20	5180	Ant1	2	10	240	9.66	68.25	Pass
NVNT	n20	5180	Ant1	2	11	114	10.8	74.5	Pass

NVNT	n20	5180	Ant1	2	12	171	12.51	80.75	Pass
NVNT	n20	5180	Ant1	2	13	269	15.19	87	Pass
NVNT	n20	5180	Ant1	2	14	254	17.73	93.25	Pass
NVNT	n20	5180	Ant1	2	15	191	19.64	99.5	Pass
NVNT	n20	5180	Ant1	2	16	8045	100	100	Pass
NVNT	n20	5240	Ant1	2	0	123	1.22	5	Pass
NVNT	n20	5240	Ant1	2	1	6	1.28	12	Pass
NVNT	n20	5240	Ant1	2	2	6	1.34	18.25	Pass
NVNT	n20	5240	Ant1	2	3	6	1.4	24.5	Pass
NVNT	n20	5240	Ant1	2	4	3	1.43	30.75	Pass
NVNT	n20	5240	Ant1	2	5	0	1.43	37	Pass
NVNT	n20	5240	Ant1	2	6	21	1.63	43.25	Pass
NVNT	n20	5240	Ant1	2	7	28	1.91	49.5	Pass
NVNT	n20	5240	Ant1	2	8	117	3.07	55.75	Pass
NVNT	n20	5240	Ant1	2	9	219	5.24	62	Pass
NVNT	n20	5240	Ant1	2	10	189	7.11	68.25	Pass
NVNT	n20	5240	Ant1	2	11	69	7.8	74.5	Pass
NVNT	n20	5240	Ant1	2	12	129	9.07	80.75	Pass
NVNT	n20	5240	Ant1	2	13	171	10.77	87	Pass
NVNT	n20	5240	Ant1	2	14	182	12.57	93.25	Pass
NVNT	n20	5240	Ant1	2	15	155	14.1	99.5	Pass
NVNT	n20	5240	Ant1	2	16	8672	100	100	Pass

Idle Period Probability NVNT a 5180MHz

Idle Period Probability

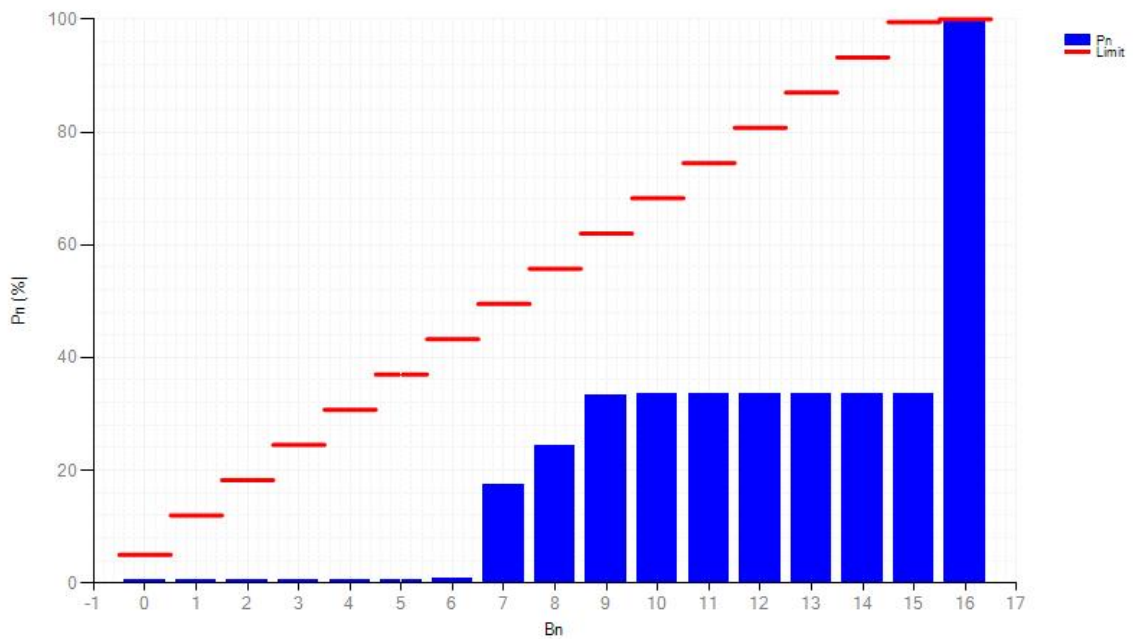

Idle Period Probability NVNT a 5240MHz

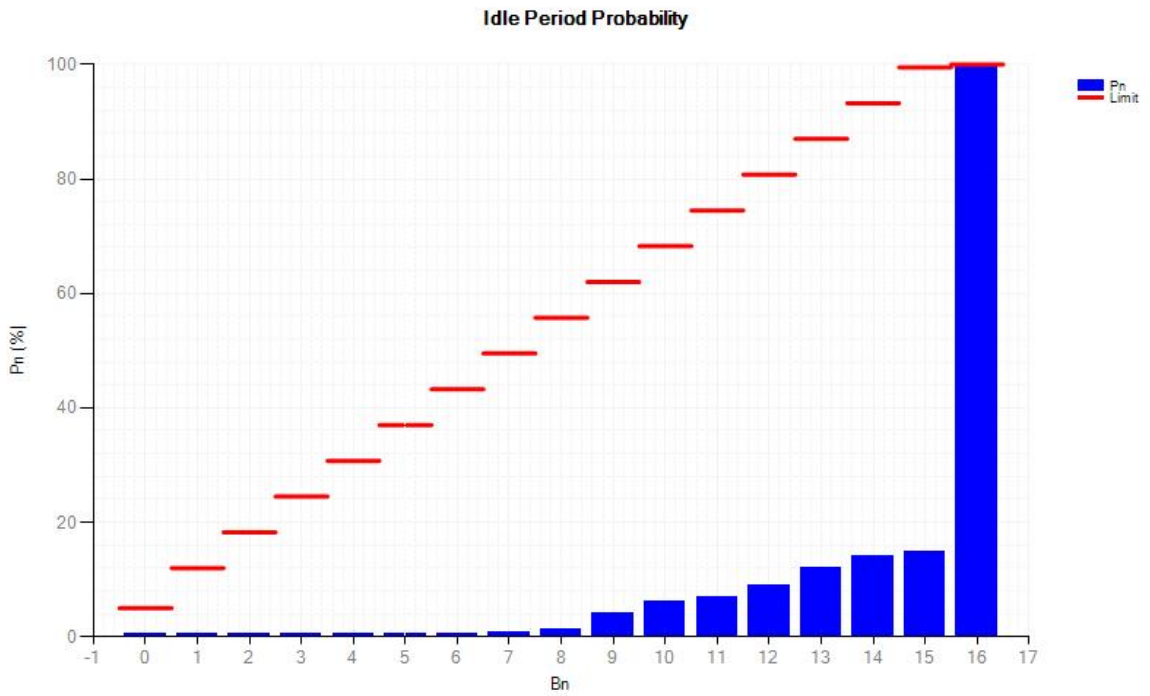

Idle Period Probability NVNT ac20 5180MHz

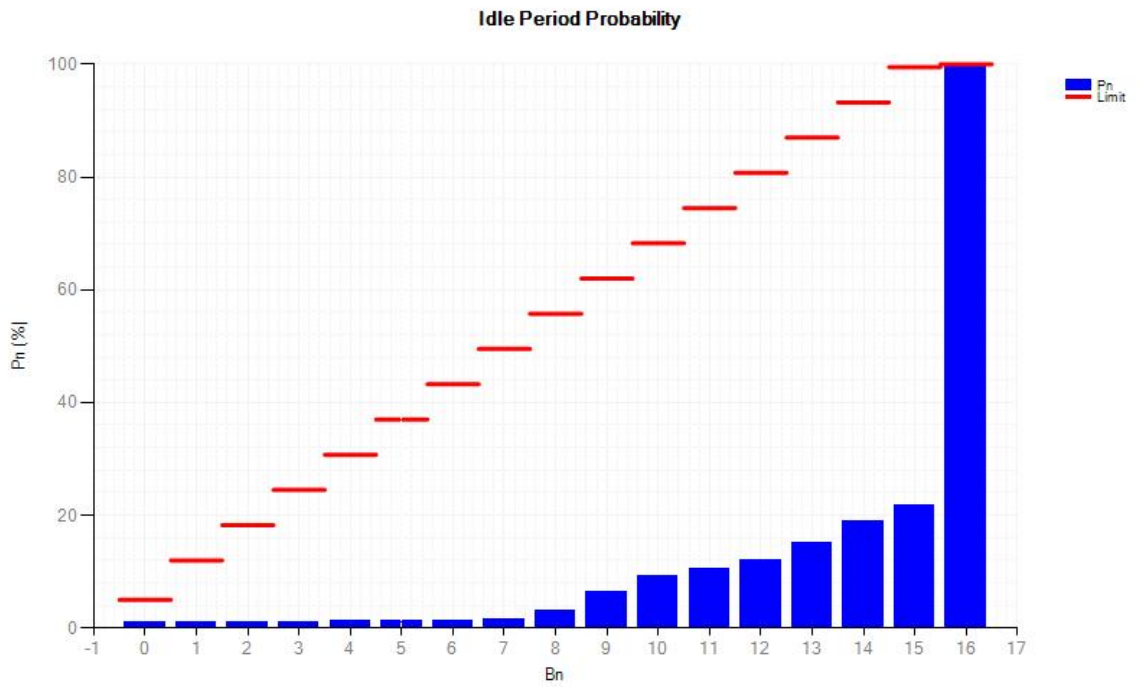

Idle Period Probability NVNT ac20 5240MHz

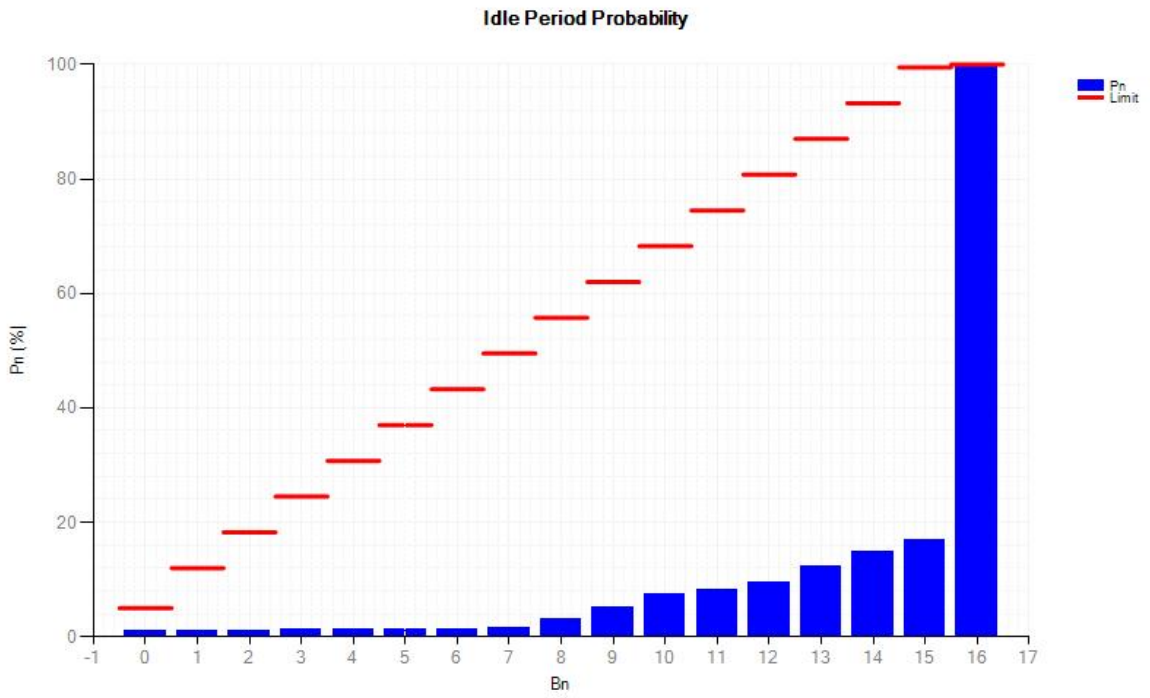

Idle Period Probability NVNT n20 5180MHz

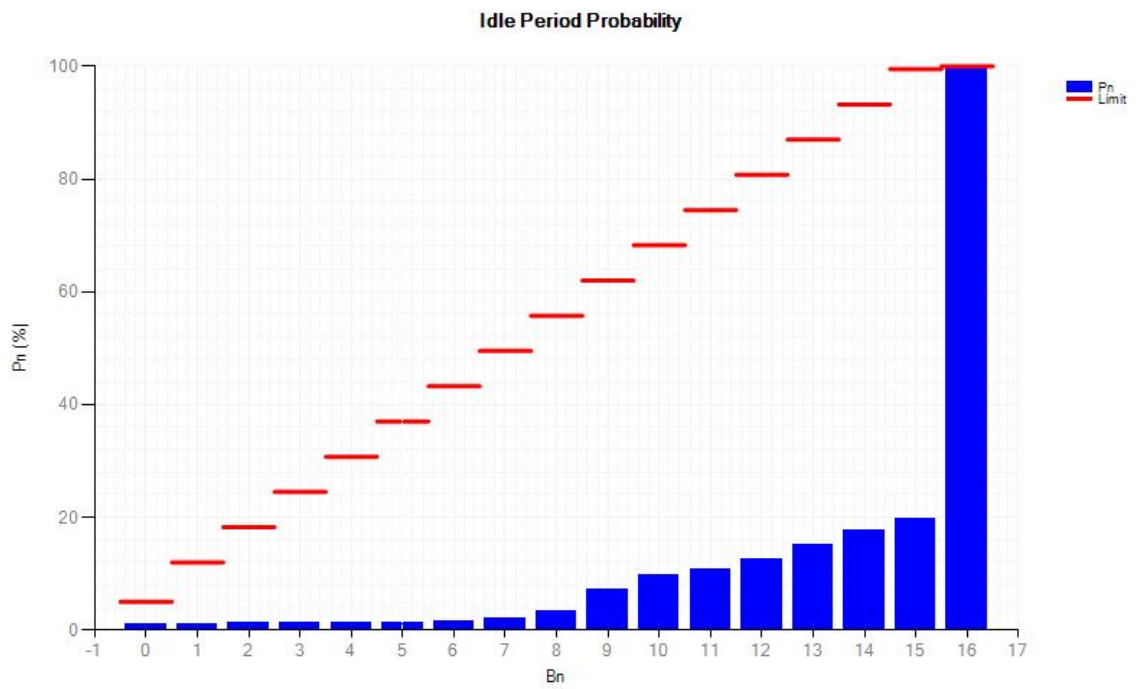

Idle Period Probability NVNT n20 5240MHz

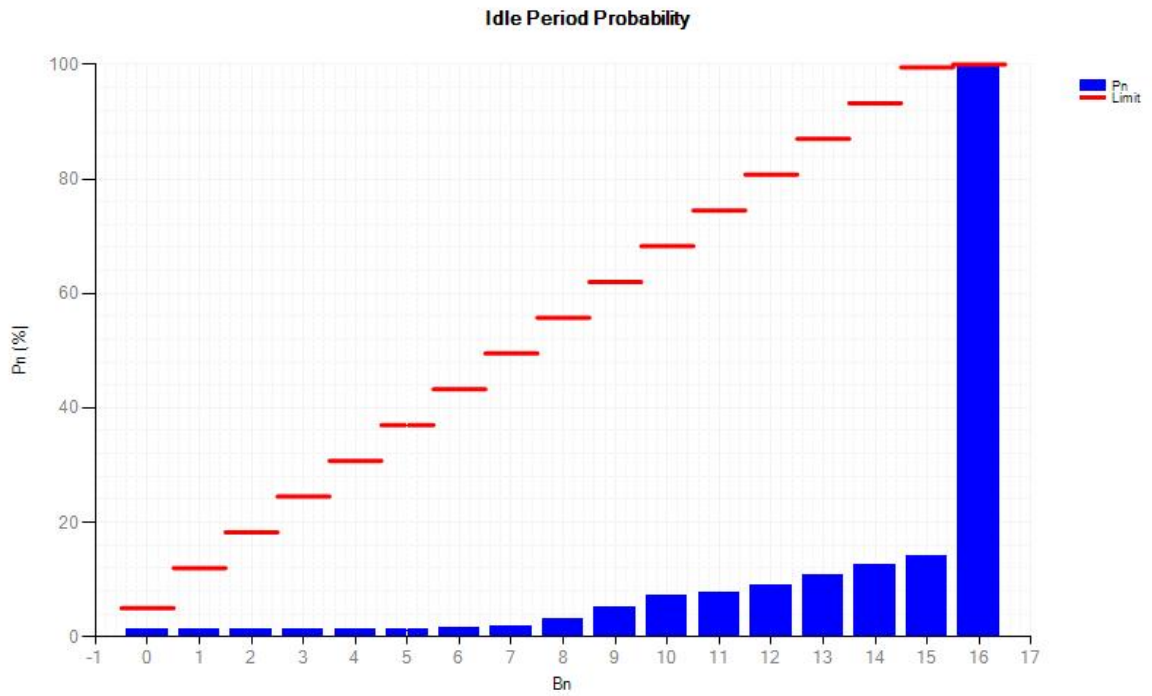

Note: This Report only show the test plots of the worst case.

12. Receiver Blocking

12.1. Limit

Wanted signal mean power from companion device (dBm)	Blocking signal frequency (MHz)	Blocking signal power (dBm) (see note 2)		Type of blocking signal
		Master or Slave with radar detection (see table D.2, note 2)	Slave without radar detection (see table D.2, note 2)	
$P_{min} + 6$ dB	5 100	-53	-59	Continuous Wave
$P_{min} + 6$ dB	4 900 5 000 5 975	-47	-53	Continuous Wave

NOTE 1: P_{min} is the minimum level of the wanted signal (in dBm) required to meet the minimum performance criteria as defined clause 4.2.8.3 in the absence of any blocking signal.

NOTE 2: The levels specified are levels in front of the UUT antenna. In case of conducted measurements, the same levels should be used at the antenna connector irrespective of antenna gain.

12.2. Test Setup

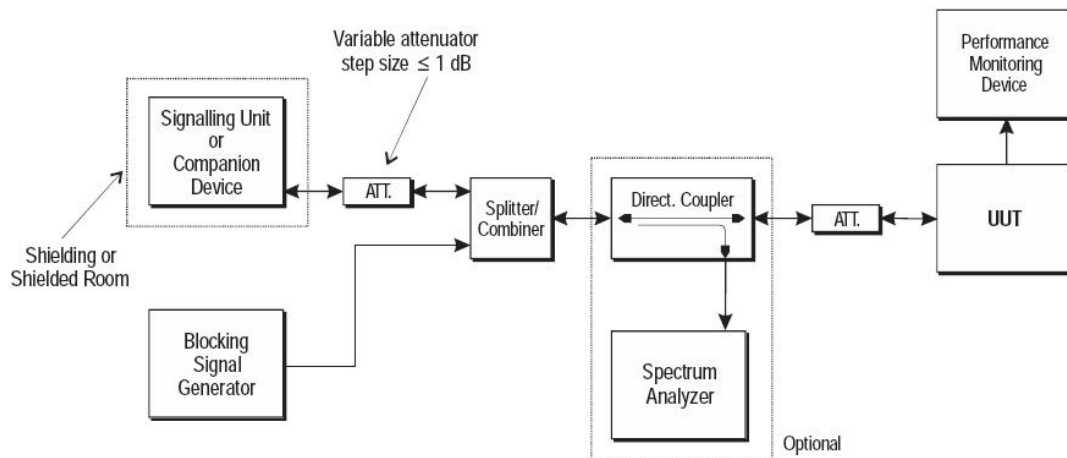

12.3. Test Procedure

Refer to ETSI EN 301 893 V2.1.1 Clause 5.4.10.2

12.4. Test Result

Receiver category 1								
U-NII-1								
Test Mode	E.I.R.P. (dBm)	Variable attenuator value (dB)	P _{min} (dBm)	Channel frequency (MHz)	Blocking signal frequency MHz	Blocking signal power dBm	PER (%)	PER limit
802.11a	13.82	79	-65.18	5180	5100	-59	1.4	≤10%
					4900	-53	1.4	≤10%
					5000	-53	1.6	≤10%
					5975	-53	1.3	≤10%
	13.53	78	-64.47	5240	5100	-59	1.3	≤10%
					4900	-53	1.5	≤10%
					5000	-53	1.6	≤10%
					5975	-53	1.2	≤10%
Test result: conform								
<p>Note: 1. The equipment shall be tested by the lowest channel bandwidth and lowest data transmitting speed operating at both the lowest and highest operating channels. The worst result is recorded.</p> <p>2. P_{min}=E.I.R.P.- Variable attenuator value. EIRP is min conducted power value.</p> <p>3. When required blocking signals injected, communication link between the UUT and the associated companion device remains, and the performance still meet the minimum performance criterion PER≤10%.</p>								

Note: This Report only show the test result of the worst case (U-NII-1(802.11a)).

13. User Access Restrictions

User Access Restrictions are restrict implemented in the RLAN to restrict access forthe user to certain hardware and/or software settings of the equipment.

14. Photos of EUT

Over view of EUT



Over view of EUT



Over view of EUT



Over view of EUT



Internal view of EUT

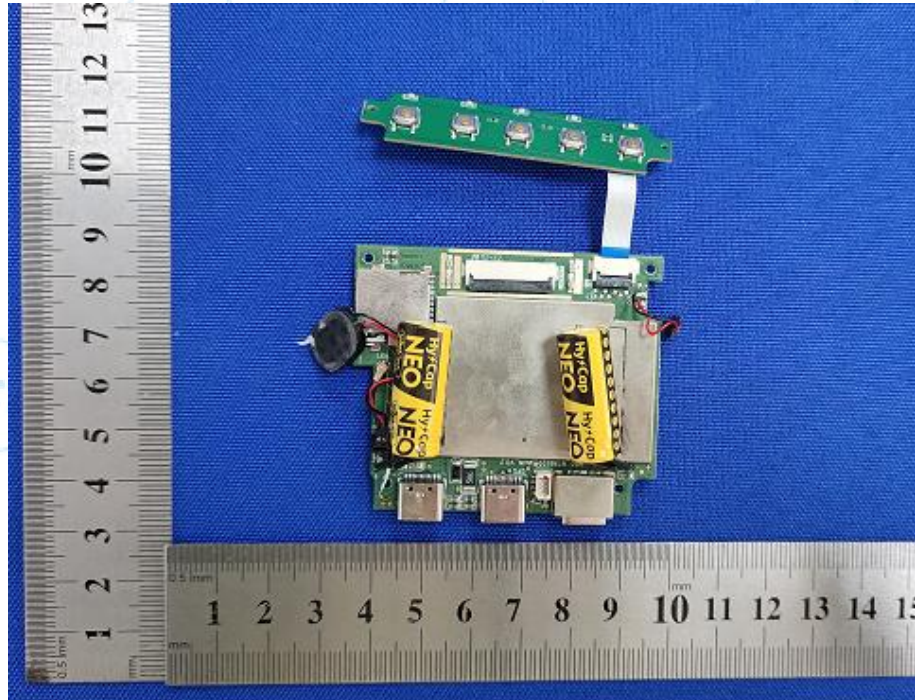

Internal view of EUT

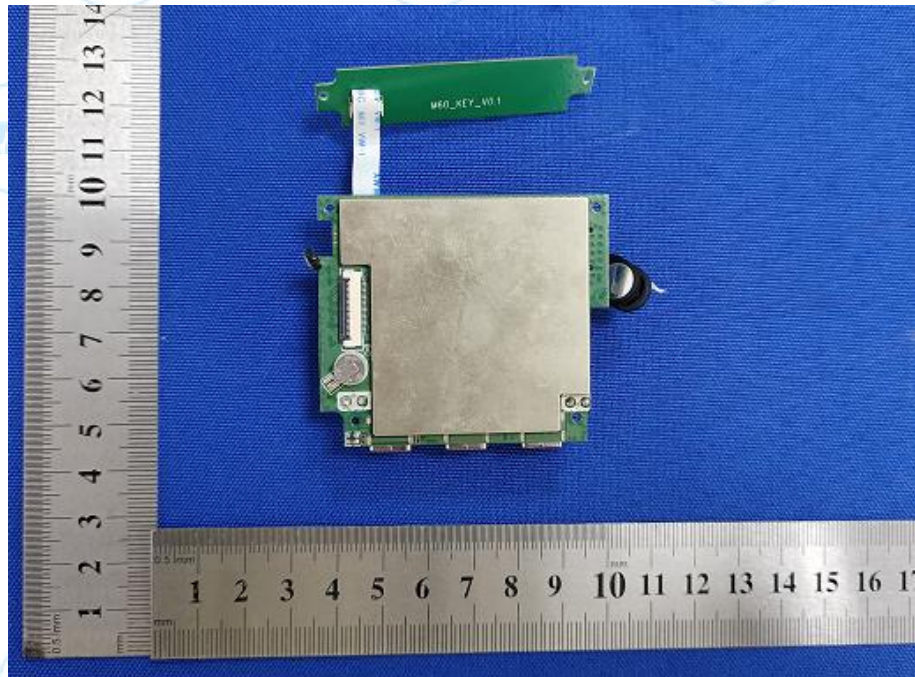

-----THE END OF REPORT-----