



## ETSI EN 300 328 RADIO TEST REPORT

On Behalf of

Shenzhen Shadow Crown Technology Co.,Ltd.

LED Projector

Model No.: See model list

Prepared for : Shenzhen Shadow Crown Technology Co.,Ltd.  
Address : 501-702, Building A9, Longwangmiao Industrial Building, East  
Baishixia Community, Fuyong Street, Baoan District, Shenzhen

Prepared By : Shenzhen Alpha Product Testing Co., Ltd.  
Address : Building i, No.2, Lixin Road, Fuyong Street, Bao'an District,  
518103, Shenzhen, Guangdong, China

Report Number : A2503316-C01-R05  
Date of Receipt : January 4, 2024  
Date of Test : January 4, 2024 – February 22, 2024  
Date of Report : April 3, 2025  
Version Number : V0  
**Test Result : Pass**

## TABLE OF CONTENTS

<b>Description</b>	<b>Page</b>
<b>1. General Information</b> .....	6
1.1. Description of Device (EUT).....	6
1.2. Categorization .....	11
1.3. Accessories of Device (EUT) .....	11
1.4. Ancillary Equipment Details .....	11
1.5. Test Lab Information.....	11
<b>2. Summary of test</b> .....	12
2.1. Test Standard description: .....	12
2.2. Summary of test result .....	12
2.3. Block Diagram of Configuration for test .....	13
2.4. Test mode .....	13
2.5. Test Conditions.....	13
2.6. Measurement Uncertainty (95% confidence levels, k=2).....	13
2.7. Test Equipment.....	14
<b>3. RF output power</b> .....	17
3.1. Limit.....	17
3.2. Test Setup .....	17
3.3. Test Procedure .....	17
3.4. Test Result.....	18
<b>4. Power Spectral Density</b> .....	19
4.1. Limit.....	19
4.2. Test Setup .....	19
4.3. Test Procedure .....	19
4.4. Test Result.....	20
<b>5. Adaptivity</b> .....	24
5.1. Limit.....	24
5.2. Test Setup .....	24
5.3. Test Procedure .....	24
5.4. Test Result.....	25
<b>6. Occupied Channel Bandwidth</b> .....	26
6.1. Limit.....	26
6.2. Test Setup .....	26
6.3. Test Procedure .....	26
6.4. Test Result.....	26
<b>7. Transmitter unwanted emissions in the out-of-band domain</b> .....	31
7.1. Limit.....	31
7.2. Test Setup .....	31
7.3. Test Procedure .....	31
7.4. Test Result.....	32
<b>8. Transmitter unwanted emissions in the spurious domain</b> .....	36
8.1. Limit.....	36

---

8.2. Test Procedure .....	36
8.3. Test Result.....	36
<b>9. Receiver Spurious emissions.....</b>	<b>39</b>
9.1. Limit.....	39
9.2. Test Procedure .....	39
9.3. Test Result.....	39
<b>10. Receiver Blocking.....</b>	<b>41</b>
10.1. Limit .....	41
10.2. Test Setup.....	43
10.3. Test Procedure.....	43
10.4. Test Result .....	43
<b>11. Geo-location capability .....</b>	<b>44</b>
11.1. Definition .....	44
11.2. Requirements .....	44
11.3. Test Result .....	44
<b>12. Photos of test setup .....</b>	<b>45</b>
<b>13. Photos of EUT .....</b>	<b>46</b>
<b>14. Model list .....</b>	<b>47</b>

### TEST REPORT DECLARATION

Applicant : Shenzhen Shadow Crown Technology Co.,Ltd.  
 Address : 501-702, Building A9, Longwangmiao Industrial Building, East Baishixia  
 Community, Fuyong Street, Baoan District, Shenzhen  
 Manufacturer : Shenzhen Shadow Crown Technology Co.,Ltd.  
 Address : 501-702, Building A9, Longwangmiao Industrial Building, East Baishixia  
 Community, Fuyong Street, Baoan District, Shenzhen  
 EUT Description : LED Projector  
 (A) Model No. : See model list  
 (B) Trademark : N/A

Measurement Standard Used:

**ETSI EN 300 328 V2.2.2:2019**

The device described above is tested by Shenzhen Alpha Product Testing Co., Ltd. The measurement results are contained in this test report and Shenzhen Alpha Product Testing Co., Ltd. is assumed full of responsibility for the accuracy and completeness of these measurements. Also, this report shows that the EUT (Equipment Under Test) is technically compliant with the EN 300 328 requirements.

This report applies to above tested sample only. This report shall not be reproduced in parts without written approval of Shenzhen Alpha Product Testing Co., Ltd.

Tested by (name + signature).....: Yannis Wen  
 Project Engineer

Approved by (name + signature).....: Jack Xu  
 Project Manager

Date of issue.....: April 3, 2025



**Revision History**

Revision	Issue Date	Revisions	Revised By
V0	April 3, 2025	Initial released Issue	Yannis Wen

## 1. General Information

### 1.1. Description of Device (EUT)

EUT Name	:	LED Projector
Model No.	:	See model list
DIFF.	:	There is no difference between the models except the appearance color. So all the test were performed on the model YG691.
Power supply	:	AC 230V/50Hz

Radio Technology	:	Bluetooth LE
Operation frequency	:	2402-2480MHz
Channel No.	:	40 channels
Channel Separation	:	2MHz
Data rate	:	1Mbps, 2Mbps
Modulation	:	GFSK
Antenna Type	:	Internal antenna, Maximum Gain is 0dBi. (Antenna information is provided by applicant.)
Software version	:	V1.0
Hardware version	:	V1.0
Intend use environment	:	Residential, commercial and light industrial environment

This Co-license is based on report A2312177-C01-R07, the new models YG201, YG203, YG210, YG211, YG213, YG221, YG223, YG233, YG241, YG243, YG251, YG253, YG261, YG263, YG271, YG273, YG283, YG293, YG301, YG303, YG311, YG313, YG321, YG323, YG333, YG341, YG343, YG351, YG353, YG363, YG373, YG383, YG393, YG401, YG403, YG413, YG423, YG433, YG441, YG443, YG451, YG453, YG463, YG473, YG481, YG483, YG493, YG501, YG501, YG511, YG513, YG521, YG523, YG531, YG533, YG541, YG543, YG553, YG563, YG571, YG573, YG583, YG593 in Co-license are the same as original models YG691, YG231, YG281, YG291, YG351, YG331, YG361, YG371, YG381, YG391, YG411, YG421, YG431, YG461, YG471, YG491, YG551, YG561, YG581, YG591, YG621, YG621mini, YG631, YG651, YG661, YG681, YG721, YG731, YG751, YG761, YG771, YG781, YG791, YG280, YG290, YG330, YG350, YG360, YG370, YG380, YG390, YG420, YG430, YG470, YG490, YG550, YG560, YG600, YG600Plus, YG620mini, YG650, YG680, YG690, YG720, YG730, YG750, YG760, YG770, YG780, YG790, W1K mentioned in test report A2312177-C01-R07 except for the address of the license holder "501-702, Building A9, Longwangmiao Industrial Building, East Baishixia Community, Fuyong Street, Baoan District, Shenzhen", no further test need.

**a) The type of modulation used by the equipment:**

- FHSS
- other forms of modulation

**b) In case of FHSS modulation:**

- In case of non-Adaptive Frequency Hopping equipment:

The number of Hopping Frequencies:

- In case of Adaptive Frequency Hopping Equipment:

The maximum number of Hopping Frequencies:

The minimum number of Hopping Frequencies:

The Dwell Time:

The Minimum Channel Occupation Time:

**c) Adaptive / non-adaptive equipment:**

- non-adaptive Equipment
- adaptive Equipment without the possibility to switch to a non-adaptive mode
- adaptive Equipment which can also operate in a non-adaptive mode

**d) In case of adaptive equipment:**

The Channel Occupancy Time implemented by the equipment: ms

- The equipment has implemented an LBT based DAA mechanism
  - In case of equipment using modulation different from FHSS:
    - The equipment is Frame Based equipment
    - The equipment is Load Based equipment
- The equipment can switch dynamically between Frame Based and Load Based equipment
  - The CCA time implemented by the equipment: .....  $\mu$ s
  - The value q as referred to in clause 4.3.2.5.2.2.2 .....
- The equipment has implemented an non-LBT based DAA mechanism
- The equipment can operate in more than one adaptive mode

**e) In case of non-adaptive Equipment:**

The maximum RF Output Power (e.i.r.p.): .....

The maximum (corresponding) Duty Cycle: ... . %

Equipment with dynamic behaviour, that behaviour is described here. (e.g. the different combinations of duty cycle and corresponding power levels to be declared):

**f) The worst case operational mode for each of the following tests:**

- RF Output Power
  - DSSS
- Power Spectral Density
  - DSSS
- Duty cycle, Tx-Sequence, Tx-gap

## DSSS

- Dwell time, Minimum Frequency Occupation & Hopping Sequence (only for FHSS equipment)
- Hopping Frequency Separation (only for FHSS equipment)
- Medium Utilisation

- .....
- Adaptivity & Receiver Blocking
- .....

- Occupied Channel Bandwidth

## DSSS

- Transmitter unwanted emissions in the OOB domain

## DSSS

- Transmitter unwanted emissions in the spurious domain

## DSSS

- Receiver spurious emissions

## DSSS

**g) The different transmit operating modes (tick all that apply):**

- Operating mode 1: Single Antenna Equipment

- Equipment with only 1 antenna

- Equipment with 2 diversity antennas but only 1 antenna active at any moment in time

- Smart Antenna Systems with 2 or more antennas, but operating in a (legacy) mode where only 1 antenna is used. (e.g. IEEE 802.11™ [i.3] legacy mode in smart antenna systems)

- Operating mode 2: Smart Antenna Systems - Multiple Antennas without beam forming

- Single spatial stream / Standard throughput / (e.g. IEEE 802.11™ [i.3] legacy mode)

- High Throughput (> 1 spatial stream) using Occupied Channel Bandwidth 1

- High Throughput (> 1 spatial stream) using Occupied Channel Bandwidth 2

NOTE: Add more lines if more channel bandwidths are supported.

- Operating mode 3: Smart Antenna Systems - Multiple Antennas with beam forming

- Single spatial stream / Standard throughput (e.g. IEEE 802.11™ [i.3] legacy mode)

- High Throughput (> 1 spatial stream) using Occupied Channel Bandwidth 1

- High Throughput (> 1 spatial stream) using Occupied Channel Bandwidth 2

NOTE: Add more lines if more channel bandwidths are supported.

**h) In case of Smart Antenna Systems:**

- The number of Receive chains: .....

- The number of Transmit chains: .....

- symmetrical power distribution

- asymmetrical power distribution

In case of beam forming, the maximum beam forming gain: .....

NOTE: Beam forming gain does not include the basic gain of a single antenna.

**i) Operating Frequency Range(s) of the equipment:**

- Operating Frequency Range 1: 2402 MHz to 2480 MHz
  - Operating Frequency Range 2:
- NOTE: Add more lines if more Frequency Ranges are supported.

**j) Occupied Channel Bandwidth(s):**

Occupied Channel Bandwidth : .....

Occupied Channel Bandwidth 2:

NOTE: Add more lines if more channel bandwidths are supported.

**k) Type of Equipment (stand-alone, combined, plug-in radio device, etc.):**

Stand-alone

Combined Equipment (Equipment where the radio part is fully integrated within another type of equipment)

Plug-in radio device (Equipment intended for a variety of host systems)

Other .....

**l) The extreme operating conditions that apply to the equipment:**

Operating temperature range:

Operating voltage range:  AC  DC

Details provided are for the:  stand-alone equipment

combined (or host) equipment

test jig

**m) The intended combination(s) of the radio equipment power settings and one or more antenna assemblies and their corresponding e.i.r.p levels:**

• Antenna Type

Rod antenna

Antenna Gain: ....dBi

If applicable, additional beamforming gain (excluding basic antenna gain): ..... dB

Temporary RF connector provided

No temporary RF connector provided

Dedicated Antennas (equipment with antenna connector)

Single power level with corresponding antenna(s)

Multiple power settings and corresponding antenna(s)

Number of different Power Levels: .....

Power Level 1: ..... dBm

Power Level 2: ..... dBm

Power Level 3: ..... dBm

NOTE 1: Add more lines in case the equipment has more power levels.

NOTE 2: These power levels are conducted power levels (at antenna connector).

**n) The nominal voltages of the stand-alone radio equipment or the nominal voltages of the combined (host) equipment or test jig in case of plug-in devices:**

Details provided are for the:  stand-alone equipment

combined (or host) equipment

test jig

Supply Voltage  AC mains State AC voltage:

DC State DC voltage :...5V

In case of DC, indicate the type of power source

Internal Power Supply

External Power Supply or AC/DC adapter

Battery: .....

Other: DC 3.7V from Battery.

**o) Describe the test modes available which can facilitate testing:**

The EUT can be into the Engineer mode for testing.

**p) The equipment type (e.g. Bluetooth®, IEEE 802.11™ [i.3], proprietary, etc.):**

Bluetooth Low Energy

**q) If applicable, the statistical analysis referred to in clause 5.4.1 q)**

Not apply

**r) If applicable, the statistical analysis referred to in clause 5.4.1 r)**

Not apply

**s) Geo-location capability supported by the equipment:**

Yes

The geographical location determined by the equipment as defined in clause 4.3.1.13.2 or clause 4.3.2.12.2 is not accessible to the user

No

**t) Describe the minimum performance criteria that apply to the equipment (see clause 4.3.1.12.3 or clause 4.3.2.11.3):**

The minimum performance criterion shall be a PER less than or equal to 10 %.

The intended use of the equipment should be in the normal operation without lost the communication link or no unintentionally operation occurs.

## 1.2. Categorization

### Receiver category 1

Adaptive equipment with a maximum RF output power greater than 10 dBm e.i.r.p. shall be considered as receiver category 1 equipment.

### Receiver category 2

Non-adaptive equipment with a Medium Utilization (MU) factor greater than 1 % and less than or equal to 10 % or adaptive equipment with a maximum RF output power of 10 Bm e.i.r.p. shall be considered as receiver category 2 equipment.

### Receiver category 3

Non-adaptive equipment with a maximum Medium Utilization (MU) factor of 1 % or adaptive equipment with a maximum RF output power of 0 dBm e.i.r.p. shall be considered as receiver category 3 equipment.

## 1.3. Accessories of Device (EUT)

Accessories : /  
 Manufacturer : /  
 Model : /  
 Ratings : /

## 1.4. Ancillary Equipment Details

No.	Description	Manufacturer	Model	Serial Number	Certification or SDoC
1	Notebook PC	Lenovo	ThinkPad E14	N/A	N/A

## 1.5. Test Lab Information

Shenzhen Alpha Product Testing Co., Ltd  
 Building i, No.2, Lixin Road, Fuyong Street, Bao'an District, 518103,  
 Shenzhen, Guangdong, China

## 2. Summary of test

### 2.1. Test Standard description:

ETSI EN 300 328 V2.2.2: Electromagnetic Compatibility and Radio Spectrum Matters(ERM); Wideband transmission systems; Data transmission equipment operating in the 2,4 GHz ISM band and using wide band modulation techniques; Harmonised Standard covering the essential requirements of article 3.2 of Directive 2014/53/EU

### 2.2. Summary of test result

Technical requirements for the equipment using wide band modulations other than FHSS:

The following essential requirements and test specifications are relevant to the presumption of conformity under Article 3.2 of Directive 2014/53/EU

No	Test Parameter	Clause No	Results
Transmitter Parameters			
1	RF output power	4.3.2.2	PASS
2	Power Spectral Density	4.3.2.3	PASS
3	Duty Cycle, Tx-sequence, Tx-gap	4.3.2.4	N/A
4	Accumulated Transmit time, Frequency Occupation & Hopping Sequence	4.3.1.4	N/A
5	Hopping Frequency Separation	4.3.1.5	N/A
6	Medium Utilisation (MU) factor	4.3.2.5	N/A
7	Adaptivity	4.3.2.6	N/A
8	Occupied Channel Bandwidth	4.3.2.7	PASS
9	Transmitter unwanted emissions in the OOB domain	4.3.2.8	PASS
10	Transmitter unwanted emissions in the spurious domain	4.3.2.9	PASS
Receiver Parameters			
11	Receiver spurious emissions	4.3.2.10	PASS
12	Receiver Blocking	4.3.2.11	PASS
13	Geo-location capability	4.3.2.12	N/A

**Note:**

1. N/A is an abbreviation for Not Applicable and means this test item is not applicable for this device according to the technology characteristic of device.
2. Decision rules for the conclusion of this test report: decision by actual test data without considering measurement uncertainty.

### 2.3. Block Diagram of Configuration for test

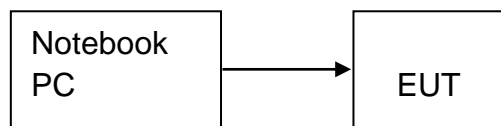

### 2.4. Test mode

The special RF test software was used to control EUT work in Continuous BT TX mode, and select test channel, wireless mode.

Mode	Data rate (Mbps)	Channel	Frequency (MHz)
GFSK	1, 2	Low : CH0	2402
	1, 2	Middle: CH19	2440
	1, 2	High: CH39	2480

### 2.5. Test Conditions

	Normal Conditions	Extreme Conditions
Temperature range	15-35°C	-10°C and 45°C
Humidity range	20-75%	20-75%
Pressure range	86-106kPa	86-106kPa
Power supply	AC 230V/50Hz	AC 110V to AC 240V (declared by the manufacturer. )
Note: 1 The test procedure described in clause 5.1 of EN 300 328 was used for extreme test procedure. 2 The Extreme Temperature and Extreme Voltages declared by the manufacturer.		

### 2.6. Measurement Uncertainty (95% confidence levels, k=2)

Item	MU	Remark
Uncertainty for Conducted Emission Test	1.63dB	
Uncertainty for Radiation Emission test in 3m chamber (30MHz to 1GHz)	3.74 dB	Polarize: V
	3.76 dB	Polarize: H
Uncertainty for Radiation Emission test in 3m chamber (1GHz to 25GHz)	3.77 dB	Polarize: H
	3.80 dB	Polarize: V
Uncertainty for radio frequency	5.06×10 <sup>-8</sup> GHz	
Uncertainty for conducted RF Power	0.40dB	

## 2.7. Test Equipment

Equipment	Manufacturer	Model No.	Firmware version	Serial No.	Last Cal.	Cal. Due day
Test Receiver	ROHDE&SCHWARZ	ESCI	4.42 SP1	101165	2023.08.16	2024.08.15
Test Receiver	ROHDE&SCHWARZ	ESR	2.28 SP1	1316.3003K03-102082-Wa	2023.08.16	2024.08.15
Loop Antenna	SCHWARZBECK	FMZB 1519B	/	00128	2023.08.16	2024.08.15
Bilog Antenna	Schwarzbeck	VULB 9168	/	9168-627	2023.08.28	2024.08.27
Spectrum analyzer	SCHWARZBECK	FSV40-N	2.3	102137	2023.08.16	2024.08.15
Spectrum analyzer	SCHWARZBECK	FSU	4.71.SP5	200002	2023.08.16	2024.08.15
Amplifier	HP	HP8347A	/	2834A00455	2023.08.16	2024.08.15
Amplifier	Agilent	8449B	/	3008A02664	2023.08.16	2024.08.15
Horn Antenna	Schwarzbeck	BBHA 9120 D	/	2106	2023.08.19	2024.08.18
L.I.S.N.#1	Schwarzbeck	NSLK8126	/	8126-466	2023.08.16	2024.08.15
L.I.S.N.#2	ROHDE&SCHWARZ	ENV216	/	101043	2023.08.16	2024.08.15
Pulse Limiter	Schwarzbeck	9516F	/	9618	2023.08.16	2024.08.15
ESD Tester	HAEFELY	PESD1610	/	H310546	2023.08.21	2024.08.20
Fixed Coaxial Attenuator(6dB Attenuation)	CD	ATT-0675	/	120540086	2023.08.16	2024.08.15
Coupling-Decoupling Network (CDN)	CD	CDN M2/M3	/	2302	2023.08.16	2024.08.15
Electromagnetic Injection Clamp (EMC-Clamp)	CD	EM-Clamp	/	0513A031201	2023.08.16	2024.08.15
Multifunctional Compact Immunity Test system	3ctest	CCS 600	CCS V4.0.9	ES0801655	2023.08.16	2024.08.15
Surge&EFT Coupling Decoupling Network	3ctest	SEPN 3832T	/	ES0951601	2023.08.16	2024.08.15
Voltage variation and PF magnetic field regulating device	3ctest	VMT2216S	/	ES0441601	2023.08.16	2024.08.15
Capacitive Coupling Clamp	3ctest	CCC 100	/	EC0441660	2023.08.16	2024.08.15
Combination Wave Surge Simulator	3ctest	CWS 600T	/	ES0311604	2023.08.16	2024.08.15
Unshielded symmetrical high - speed Interconnection Lines Coupling Decoupling Network	3ctest	CDN 405T8A1	/	ES2731602	2023.08.16	2024.08.15
Conducted	SKET	CITS_150K2	/	SK201910100	2023.08.16	2024.08.15

Immunity test System		30M		1_CITS		
Universal Radio Communication Tester	ROHDE&SCHWARZ	CMU200	V5.21	116785	2023.08.16	2024.08.15
Signal Generator	Agilent	N5182A	/	MY49060042	2023.08.16	2024.08.15
Vector Signal Generator	Agilent	E4438C	/	US44271917	2023.08.16	2024.08.15
Power meter	Agilent	E4419B	/	GB40202122	2023.08.16	2024.08.15
Power Sensor	Agilent	E9300A	/	MY41496628	2023.08.16	2024.08.15
Power Sensor	Agilent	E9304A	/	MY41496815	2023.08.16	2024.08.15
RF power Amplifier	OPHIR	5225R	/	1045	2023.08.16	2024.08.15
RF power Amplifier	OPHIR	5273R	/	1018	2023.08.16	2024.08.15
Antenna	SCHWARZBECK	STLP9128E-special	/	STLP9128Es#139	N/A	N/A
Antenna	SCHWARZBECK	STLP9128E-special	/	STLP 9149#456	N/A	N/A
CMW500	ROHDE&SCHWARZ	CMW500	V 3.7.22	1201.0002K50-117239-sM	2023.08.16	2024.08.15
ISN	SCHWARZBECK	CAT3 8158	/	CAT3 8158#167	2023.08.16	2024.08.15
ISN	SCHWARZBECK	CAT5 8158	/	S/N: 00316	2023.08.16	2024.08.15
ISN	SCHWARZBECK	NTFM 8158	/	S/N: 00273	2023.08.16	2024.08.15
HARMINICS&FLICKER MEASUREMENT SYSTEM	EVERFINE	HFM300_V200	/	200602005	2023.04.21	2024.04.20
BROADCAST TEST SYSTEM	R&S	SFU	/	100056	2023.08.16	2024.08.15
TV SIGNAL GENERATOR	FLUKE	54200M01	/	817010	2023.08.16	2024.08.15
AM/FM STEREO SIGNAL GENERATOR	MEGURO	MSG-2280	/	61080249	2023.08.16	2024.08.15
9*6*6 anechoic chamber	CHENYU	9*6*6	/	/	2022.05.18	2025.05.17
8*4*3 Shielded room	CHENYU	8*4*3	/	/	2022.05.18	2025.05.17
8*4*3 Shielded room	CHENYU	8*4*3	/	/	2022.05.18	2025.05.17

<b>Software Information</b>			
Test Item	Software Name	Manufacturer	Version
RE	EZ-EMC	Farad	Alpha-3A1
RF-CE	MTS 8310	MWRFtest	2.0.0.0

### 3. RF output power

#### 3.1. Limit

The RF output power for non-FHSS equipment shall be equal to or less than 20 dBm.

NOTE: For Non-adaptive FHSS equipment, the manufacturer may have declared a reduced RF Output Power (see clause 5.4.1 m)) and associated Duty Cycle (see clause 5.4.1 e)) that will ensure that the equipment meets the requirement for the Medium Utilization (MU) factor further described in clause 4.3.2.5. This is verified by the conformance test referred to in clause 4.3.2.5.4.

For non-adaptive non-FHSS equipment, where the manufacturer has declared an RF output power of less than 20 dBm e.i.r.p., the RF output power shall be equal to or less than that declared value.

This limit shall apply for any combination of power level and intended antenna assembly.

Limit
20dBm

#### 3.2. Test Setup

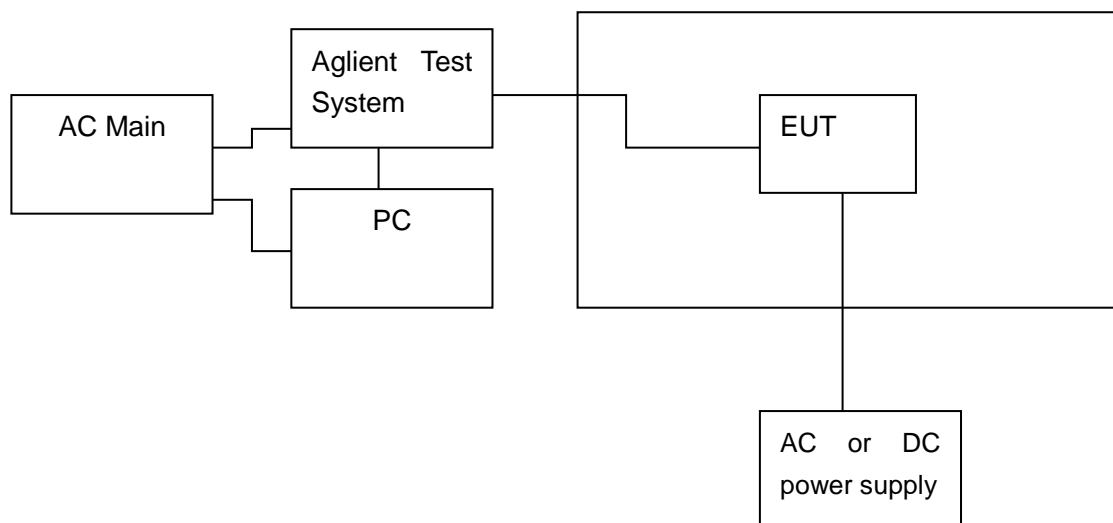

#### 3.3. Test Procedure

Refer to ETSI EN 300 328 V2.2.2:2019 Clause 5.4.2.

## 3.4. Test Result

Condition	Mode	Frequency (MHz)	Antenna	Max Burst RMS Power (dBm)	Burst Number	Max EIRP (dBm)	Limit (dBm)	Verdict
NVHT	BLE 1M	2402	Ant1	1.02	161	1.02	20	Pass
NVHT	BLE 1M	2440	Ant1	1.05	161	1.05	20	Pass
NVHT	BLE 1M	2480	Ant1	1.15	161	1.15	20	Pass
NVLT	BLE 1M	2402	Ant1	0.77	161	0.77	20	Pass
NVLT	BLE 1M	2440	Ant1	1.07	160	1.07	20	Pass
NVLT	BLE 1M	2480	Ant1	1.26	161	1.26	20	Pass
NVNT	BLE 1M	2402	Ant1	0.84	161	0.84	20	Pass
NVNT	BLE 1M	2440	Ant1	2.83	160	2.83	20	Pass
NVNT	BLE 1M	2480	Ant1	2.39	160	2.39	20	Pass

Condition	Mode	Frequency (MHz)	Antenna	Max Burst RMS Power (dBm)	Burst Number	Max EIRP (dBm)	Limit (dBm)	Verdict
NVHT	BLE 2M	2402	Ant1	0.34	160	0.34	20	Pass
NVHT	BLE 2M	2440	Ant1	0.43	161	0.43	20	Pass
NVHT	BLE 2M	2480	Ant1	0.59	161	0.59	20	Pass
NVLT	BLE 2M	2402	Ant1	-0.03	160	-0.03	20	Pass
NVLT	BLE 2M	2440	Ant1	0.05	160	0.05	20	Pass
NVLT	BLE 2M	2480	Ant1	0.33	160	0.33	20	Pass
NVNT	BLE 2M	2402	Ant1	0.31	160	0.31	20	Pass
NVNT	BLE 2M	2440	Ant1	0.33	160	0.33	20	Pass
NVNT	BLE 2M	2480	Ant1	0.19	160	0.19	20	Pass

## 4. Power Spectral Density

### 4.1. Limit

The maximum Power Spectral Density for non-FHSS equipment is 10 dBm per MHz.

Limit
10dBm/MHz

### 4.2. Test Setup

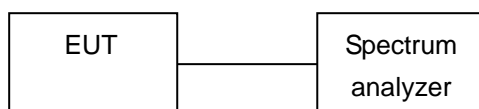

### 4.3. Test Procedure

Refer to ETSI EN 300 328 V2.2.2:2019 Clause 5.4.3

Connect the UUT to the spectrum analyzer and use the following settings:

Frequency range	2400MHz-2483.5MHz
RBW/VBW	10KHz/30KHz
Sweep points/time	>8350 / 10S
Detector	RMS
Trace	Max hold

4.4. Test Result

Condition	Mode	Frequency (MHz)	Antenna	Max PSD (dBm/MHz)	Limit (dBm/MHz)	Verdict
NVNT	BLE 1M	2402	Ant1	0.81	10	Pass
NVNT	BLE 1M	2440	Ant1	2.8	10	Pass
NVNT	BLE 1M	2480	Ant1	2.36	10	Pass

PSD NVNT BLE 1M 2402MHz Ant1

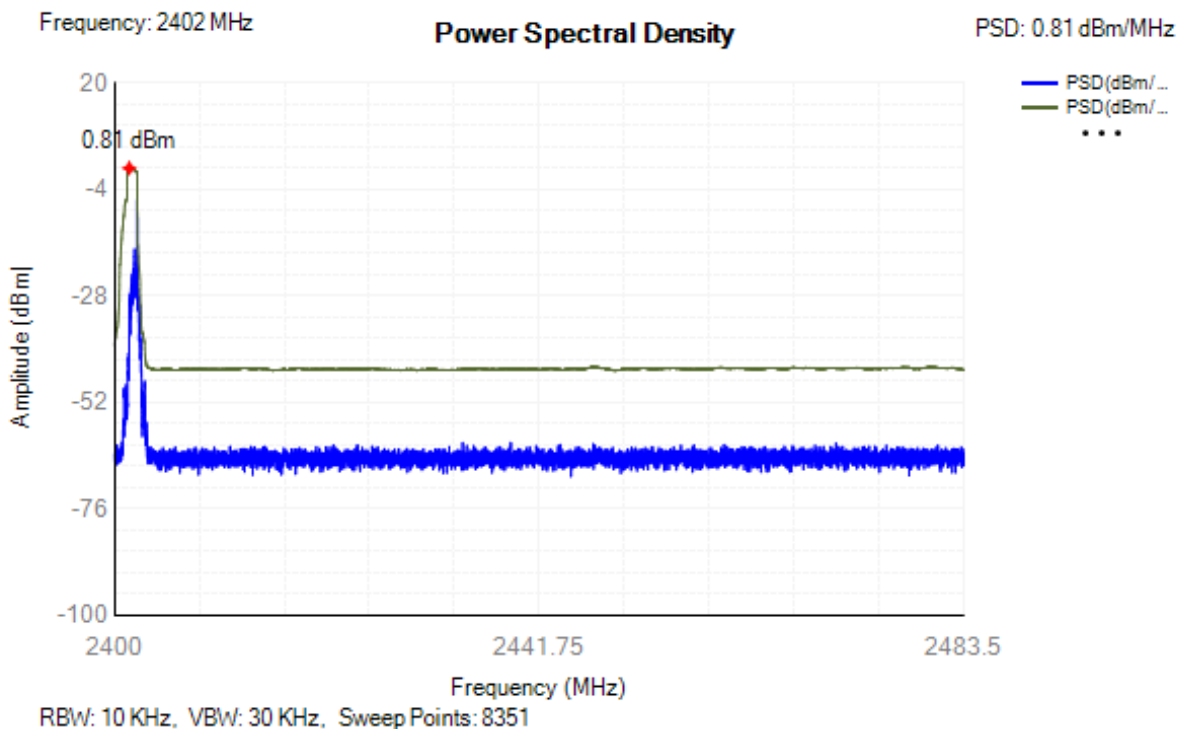

PSD NVNT BLE 1M 2440MHz Ant1

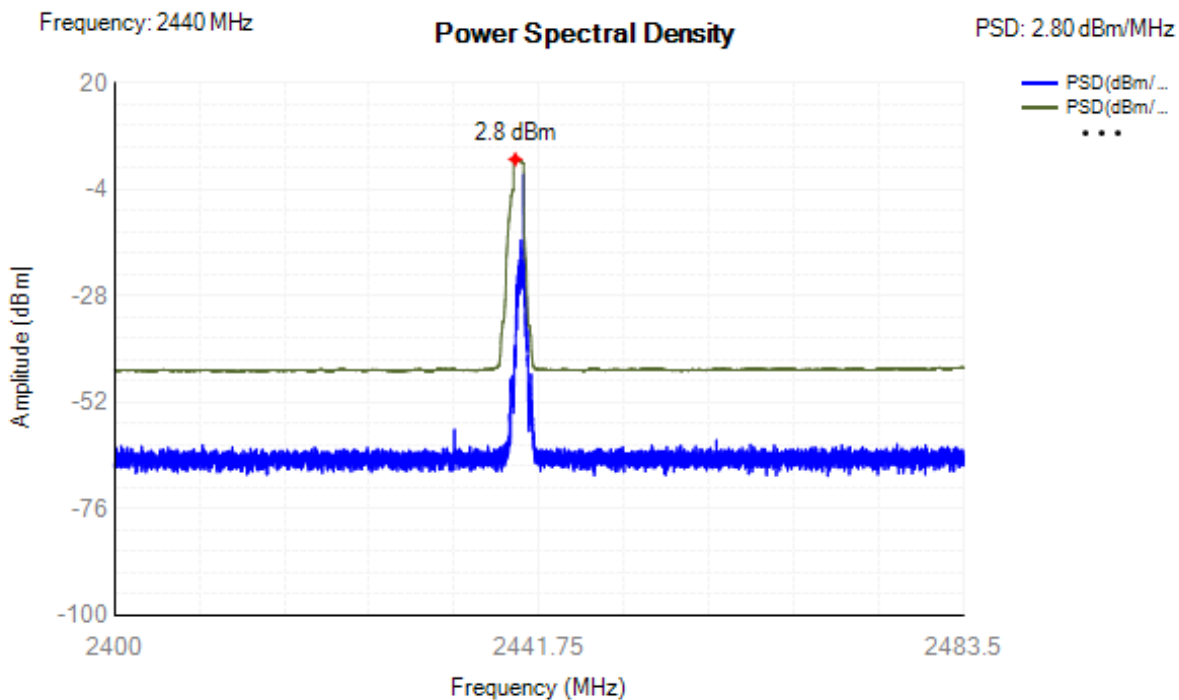

PSD NVNT BLE 1M 2480MHz Ant1

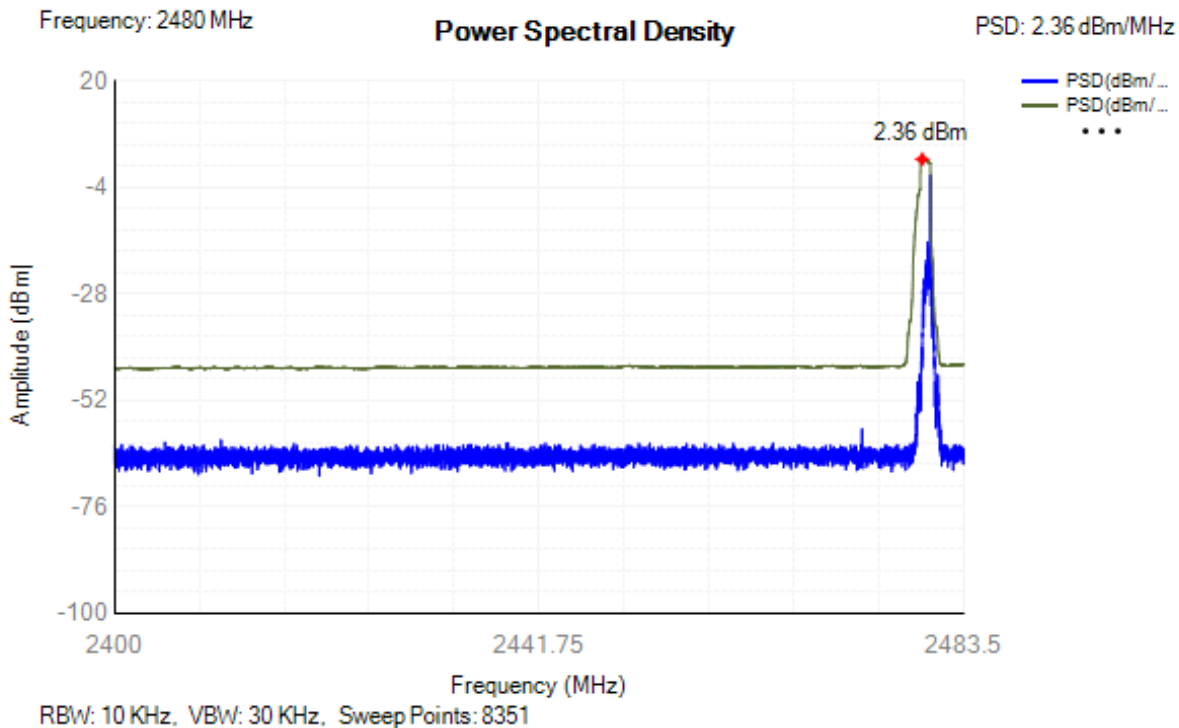

Condition	Mode	Frequency (MHz)	Antenna	Max PSD (dBm/MHz)	Limit (dBm/MHz)	Verdict
NVNT	BLE 2M	2402	Ant1	-0.96	10	Pass
NVNT	BLE 2M	2440	Ant1	-0.94	10	Pass
NVNT	BLE 2M	2480	Ant1	-1.09	10	Pass

PSD NVNT BLE 2M 2402MHz Ant1

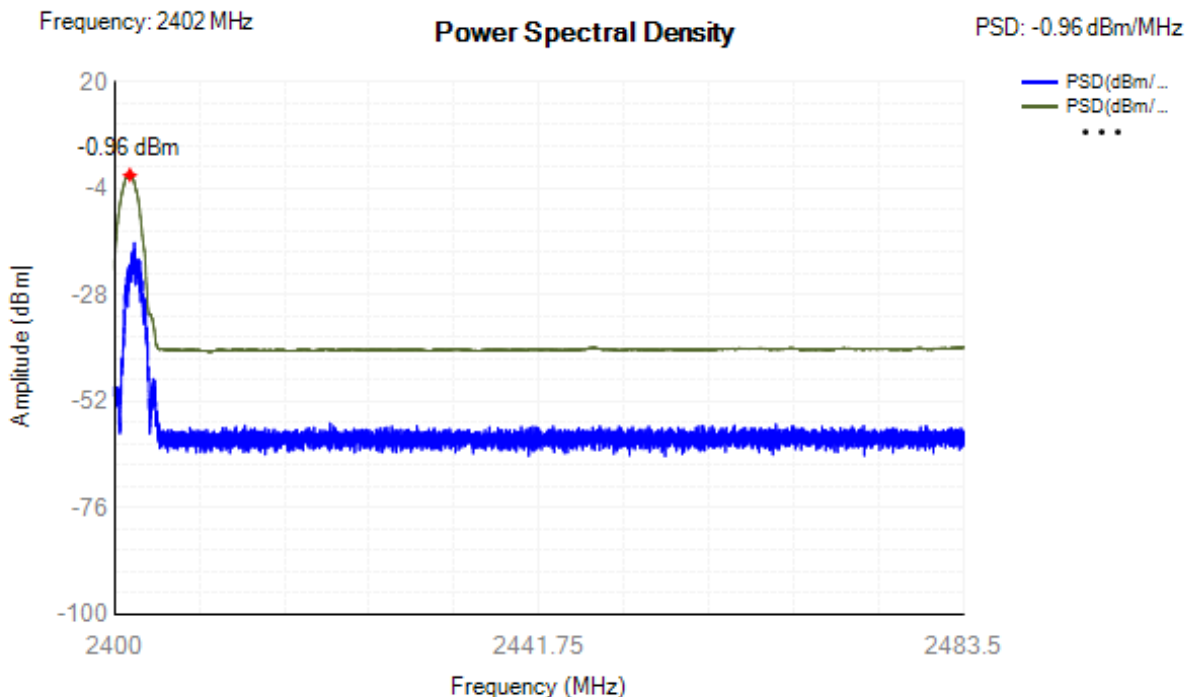

PSD NVNT BLE 2M 2440MHz Ant1

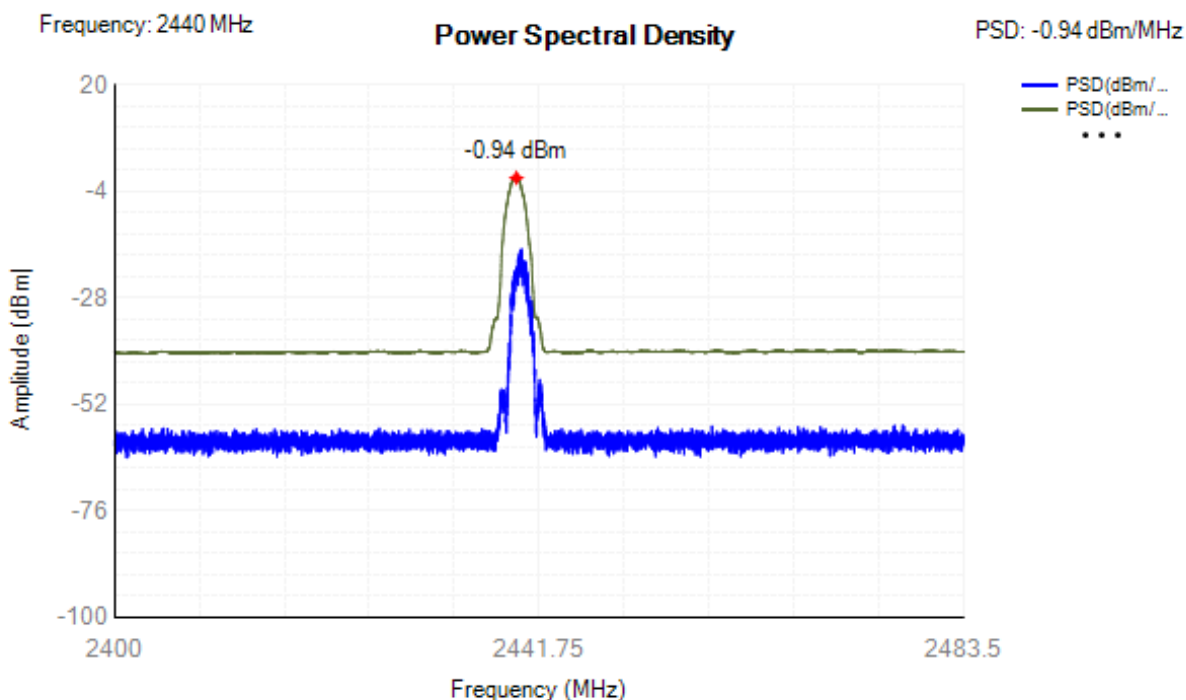

PSD NVNT BLE 2M 2480MHz Ant1

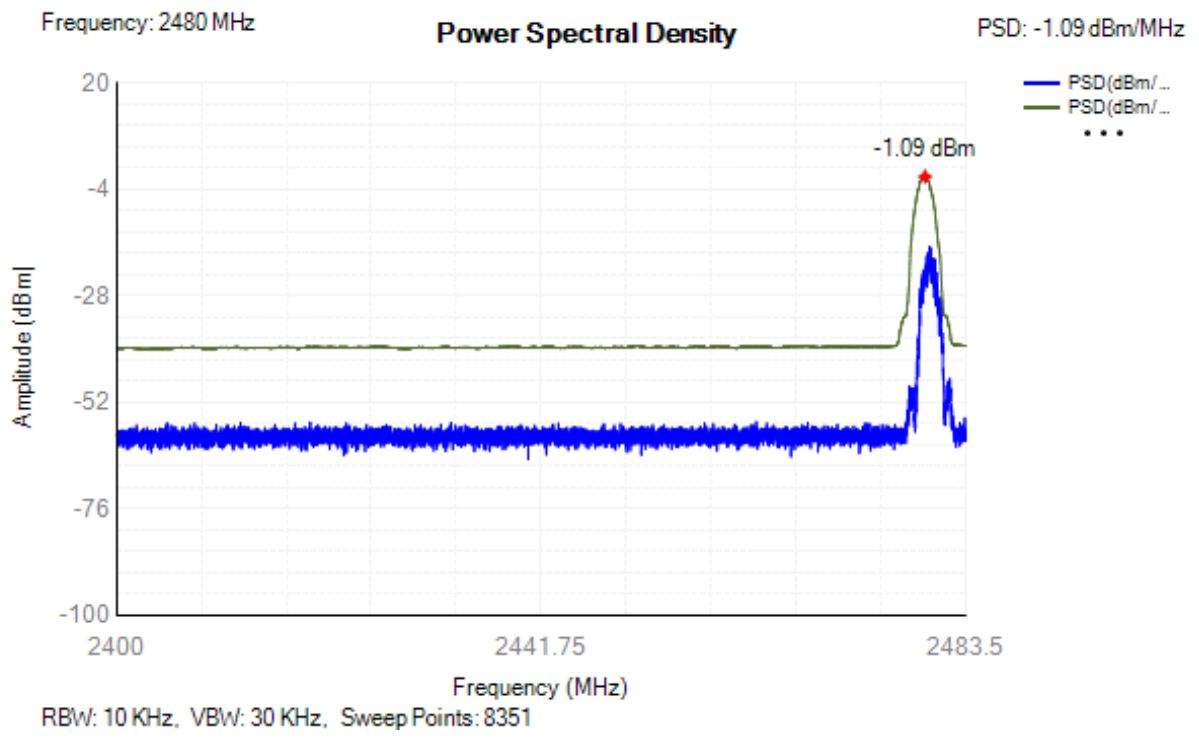

## 5. Adaptivity

### 5.1. Limit

The frequency range of the equipment is determined by the lowest and highest

#### Non-LBT based Detect And Avoid:

1 The hopping frequency shall remain unavailable for a minimum time equal to 1 second or 5 times the actual number of hopping frequencies in the current (adapted) channel map used by the equipment, multiplied with the Channel Occupancy Time whichever is greater. There shall be no transmissions during this silent period on this hopping frequency. After this, the hopping frequency may be considered again as an 'available' frequency.;

2 COT < 40 ms;

3 Idle Period = 5% of COT ≥ 100 μs;

4 Detection threshold level =  $-70 \text{ dBm/MHz} + 10 \times \log_{10} (100 \text{ mW} / P_{\text{out}})$  ( $P_{\text{out}}$  in mW e.i.r.p.);

#### LBT based Detect And Avoid (Frame Based Equipment):

1 Minimum Clear Channel Assessment (CCA) time = 18 μs;

2 CCA observation time declared by the supplier;

3 COT < 60 ms;

4 Idle Period = 5% of COT ≥ 100 μs;

5 Detection threshold level =  $-70 \text{ dBm/MHz} + 10 \times \log_{10} (100 \text{ mW} / P_{\text{out}})$  ( $P_{\text{out}}$  in mW e.i.r.p.);

#### Short Control Signalling Transmissions:

Short Control Signalling Transmissions shall have a maximum TxOn / (TxOn + TxOff) ratio of 10% within an observation period of 50ms or within an observation period equal to the dwell time, whichever is less.

### 5.2. Test Setup

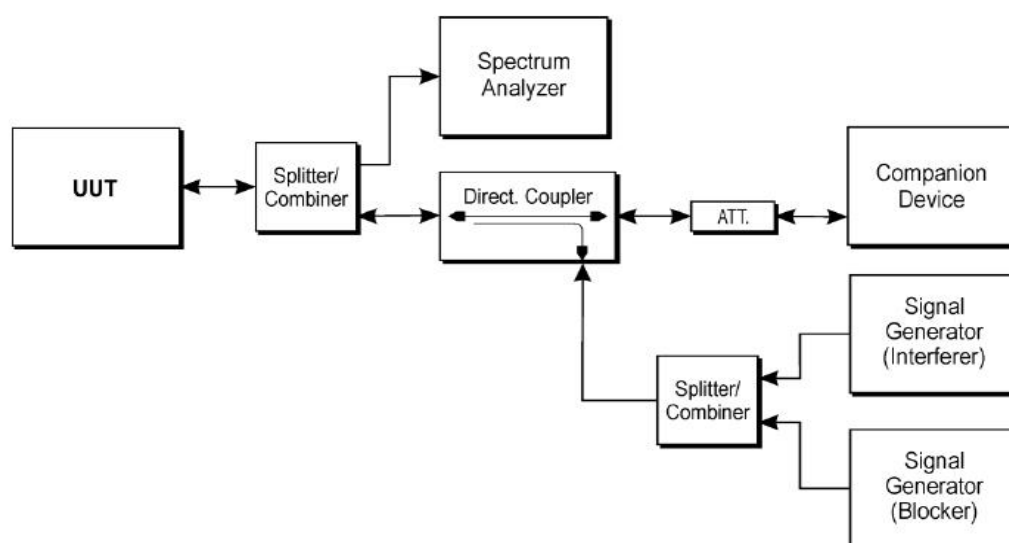

### 5.3. Test Procedure

Refer to ETSI EN 300 328 V2.2.2:2019 Clause 5.4.6.

#### 5.4. Test Result

Not applicable

Note : The maximum output power of EUT less than 10dBm, so not applicable.

## 6. Occupied Channel Bandwidth

### 6.1. Limit

The Occupied Channel Bandwidth shall be within the band 2.4GHz to 2.4835GHz.

In addition, for non-adaptive non-FHSS equipment with e.i.r.p. greater than 10 dBm, the Occupied Channel Bandwidth shall be equal to or less than 20 MHz.

### 6.2. Test Setup

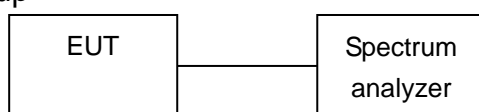

### 6.3. Test Procedure

Refer to ETSI EN 300 328 V2.2.2:2019 Clause 5.4.7.

Connect the UUT to the spectrum analyzer and use the following settings:

Centre Frequency	The centre frequency of the channel under test
Frequency Span	2 x Nominal Channel Bandwidth (e.g. 2 MHz for a 1 MHz channel)
RBW	~ 1 % of the span without going below 1 %
VBW	3 x RBW
Detector	RMS
Trace	Max hold
Sweep Time	1s

### 6.4. Test Result

Condition	Mode	Frequency (MHz)	Antenna	Center Frequency (MHz)	OBW (MHz)	Lower Edge (MHz)	Upper Edge (MHz)	Limit OBW (MHz)	Verdict
NVNT	BLE 1M	2402	Ant1	2401.982	0.935	2401.514	2402.45	2400 - 2483.5MHz	Pass
NVNT	BLE 1M	2440	Ant1	2439.988	0.939	2439.518	2440.458	2400 - 2483.5MHz	Pass
NVNT	BLE 1M	2480	Ant1	2479.992	0.935	2479.524	2480.46	2400 - 2483.5MHz	Pass

### OBW NVNT BLE 1M 2402MHz Ant1



Date: 25.JAN.2024 14:20:42

### OBW NVNT BLE 1M 2440MHz Ant1



Date: 25.JAN.2024 14:26:18

OBW NVNT BLE 1M 2480MHz Ant1

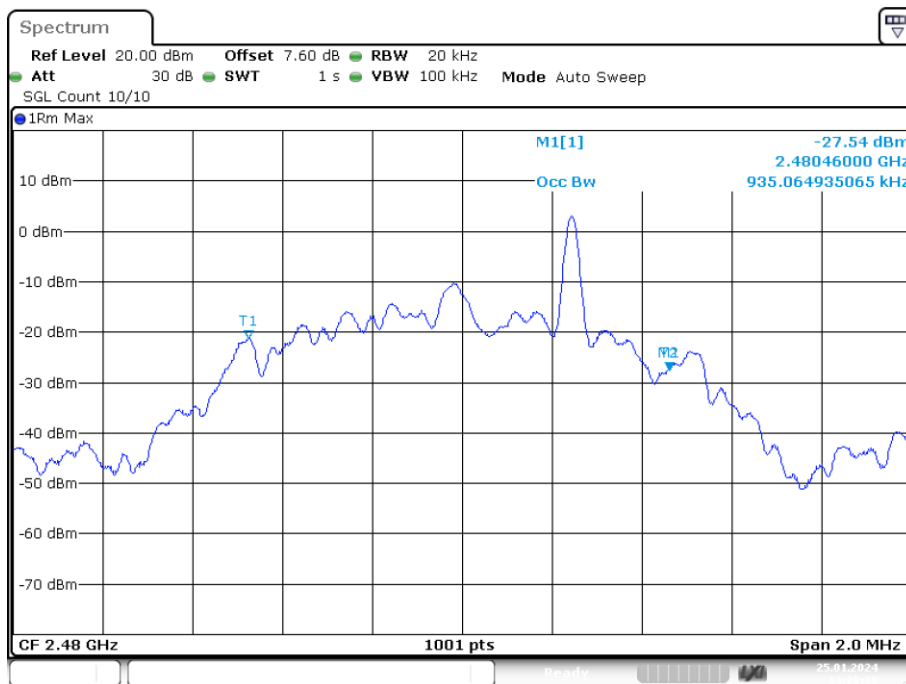

Date: 25.JAN.2024 14:28:38

Condition	Mode	Frequency (MHz)	Antenna	Center Frequency (MHz)	OBW (MHz)	Lower Edge (MHz)	Upper Edge (MHz)	Limit OBW (MHz)	Verdict
NVNT	BLE 2M	2402	Ant1	2402.01	2.074	2400.973	2403.047	2400 - 2483.5MHz	Pass
NVNT	BLE 2M	2440	Ant1	2440.008	2.07	2438.973	2441.043	2400 - 2483.5MHz	Pass
NVNT	BLE 2M	2480	Ant1	2480.01	2.058	2478.981	2481.039	2400 - 2483.5MHz	Pass

### OBW NVNT BLE 2M 2402MHz Ant1

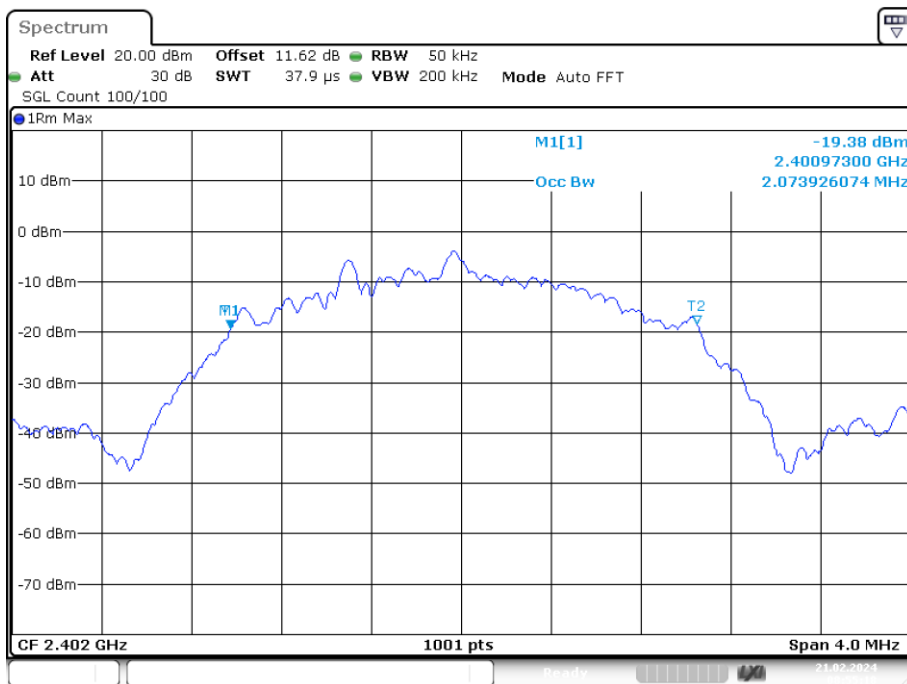

### OBW NVNT BLE 2M 2440MHz Ant1



### OBW NVNT BLE 2M 2480MHz Ant1

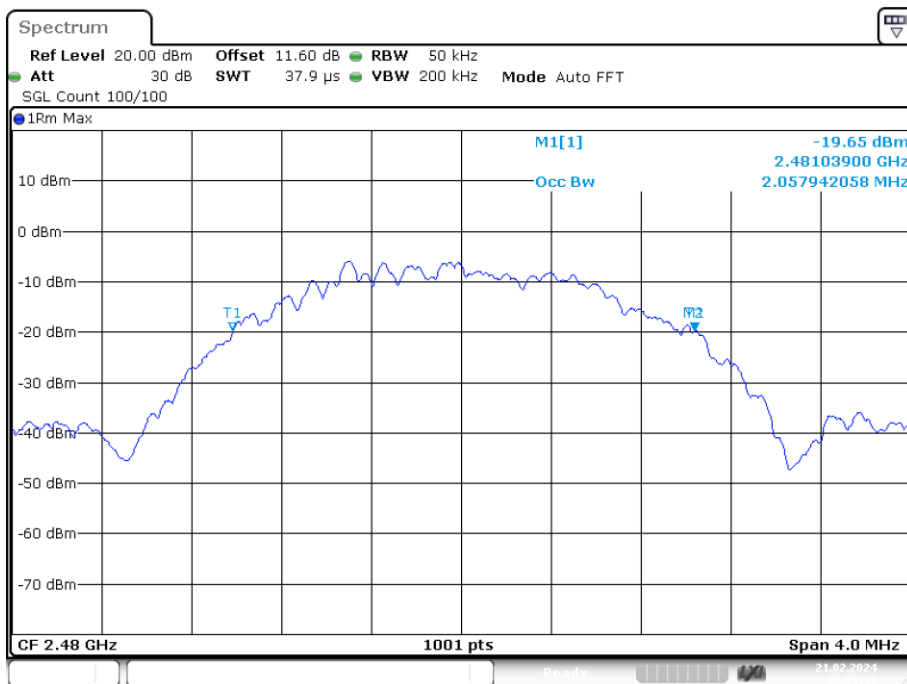

Date: 21.FEB.2024 08:59:48

## 7. Transmitter unwanted emissions in the out-of-band domain

### 7.1. Limit

The transmitter unwanted emissions in the out-of-band domain but outside the allocated band, shall not exceed the values provided by the mask in figure 3.

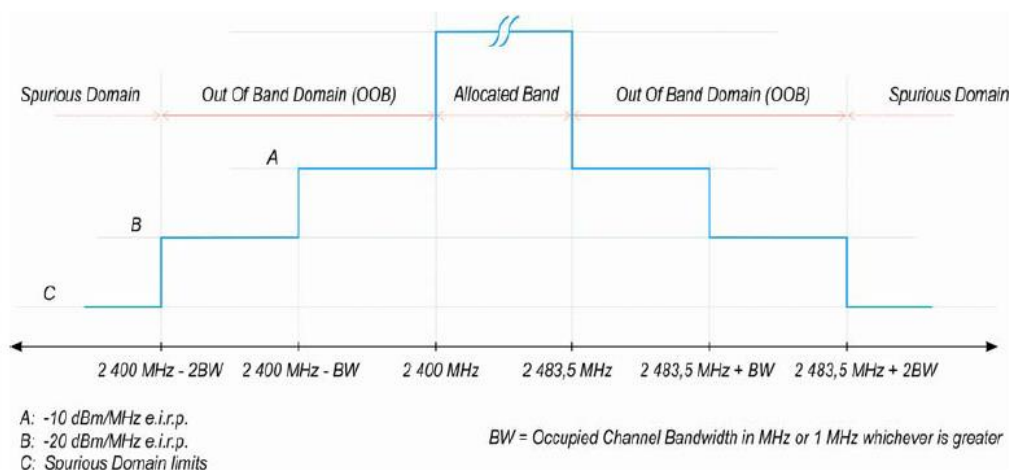
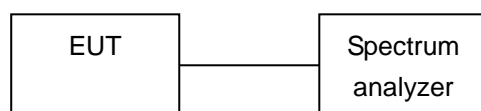

Figure 3: Transmit mask

### 7.2. Test Setup



### 7.3. Test Procedure

Refer to ETSI EN 300 328 V2.2.2:2019 Clause 5.4.8.

Connect the UUT to the spectrum analyzer and use the following settings:

RBW/ VBW	1MHz/3MHz
Span	0Hz
Filter mode	Channel filter
Sweep mode	Single Sweep
Sweep Points	Sweep time [ $\mu$ s] / (1 $\mu$ s) with a maximum of 30 000
Sweep Time:	> 120 % of the duration of the longest burst detected during the measurement of the RF Output Power
Detector	RMS
Trace mode	Max Hold
Trigger Mode	Video trigger

7.4. Test Result

Condition	Mode	Frequency (MHz)	Antenna	OOB Frequency (MHz)	Level (dBm/MHz)	Limit (dBm/MHz)	Verdict
NVNT	BLE 1M	2402	Ant1	2399.5	-50.1	-10	Pass
NVNT	BLE 1M	2402	Ant1	2398.5	-52.64	-20	Pass
NVNT	BLE 1M	2480	Ant1	2484	-52.3	-10	Pass
NVNT	BLE 1M	2480	Ant1	2485	-53.25	-20	Pass

Tx. Emissions OOB NVNT BLE 1M 2402MHz Ant1

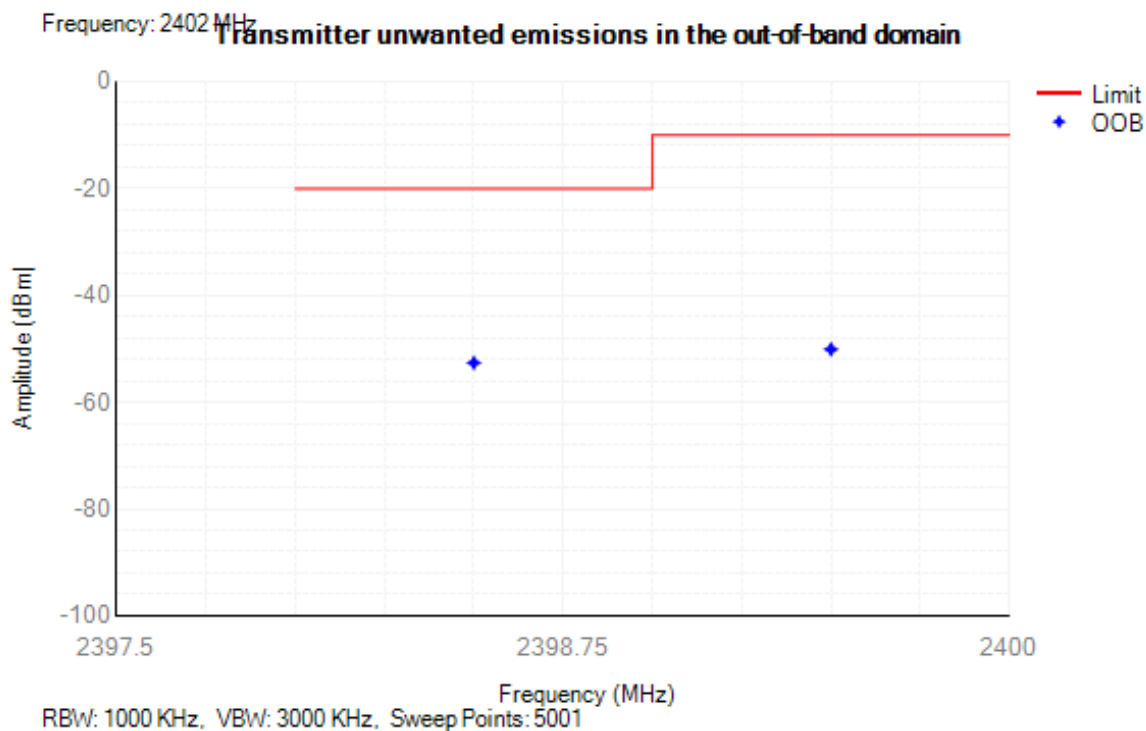

Tx. Emissions OOB NVNT BLE 1M 2480MHz Ant1

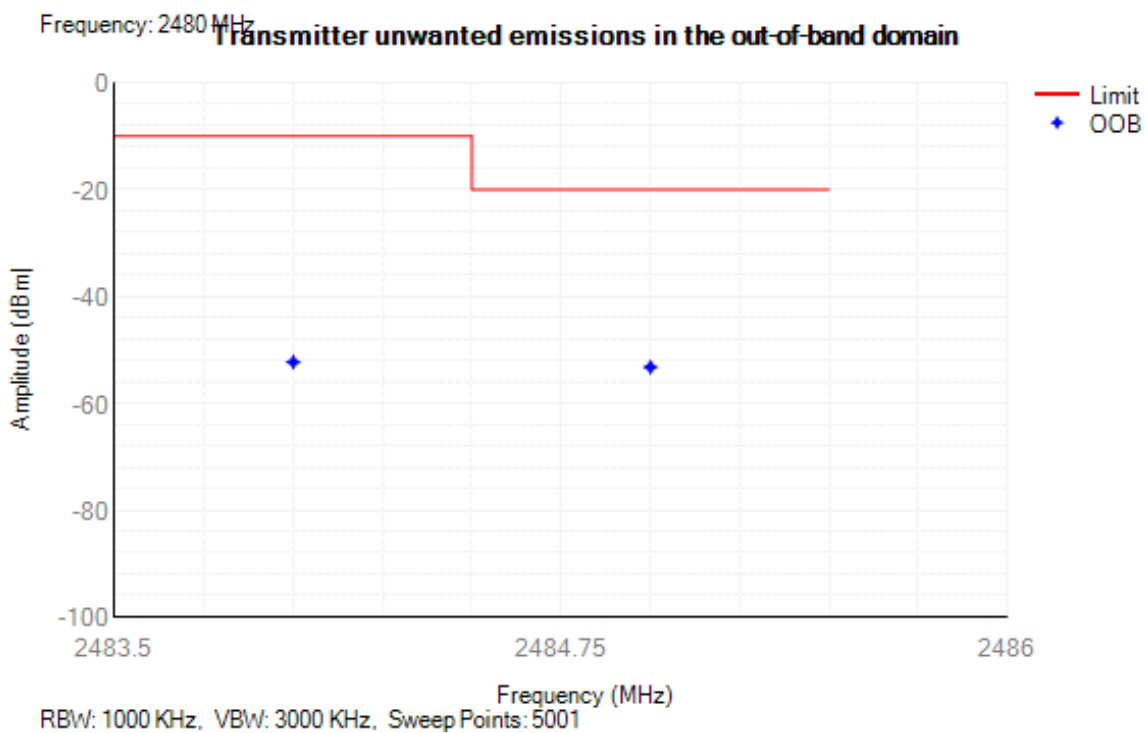

Condition	Mode	Frequency (MHz)	Antenna	OOB Frequency (MHz)	Level (dBm/MHz)	Limit (dBm/MHz)	Verdict
NVNT	BLE 2M	2402	Ant1	2399.5	-33.01	-10	Pass
NVNT	BLE 2M	2402	Ant1	2398.5	-49.24	-10	Pass
NVNT	BLE 2M	2402	Ant1	2398.426	-49.43	-10	Pass
NVNT	BLE 2M	2402	Ant1	2397.426	-50	-20	Pass
NVNT	BLE 2M	2402	Ant1	2396.426	-50.04	-20	Pass
NVNT	BLE 2M	2402	Ant1	2396.352	-49.96	-20	Pass
NVNT	BLE 2M	2480	Ant1	2484	-49.94	-10	Pass
NVNT	BLE 2M	2480	Ant1	2485	-49.96	-10	Pass
NVNT	BLE 2M	2480	Ant1	2485.058	-50.04	-10	Pass
NVNT	BLE 2M	2480	Ant1	2486.058	-50.05	-20	Pass
NVNT	BLE 2M	2480	Ant1	2487.058	-50.02	-20	Pass
NVNT	BLE 2M	2480	Ant1	2487.116	-50.02	-20	Pass

Tx. Emissions OOB NVNT BLE 2M 2402MHz Ant1

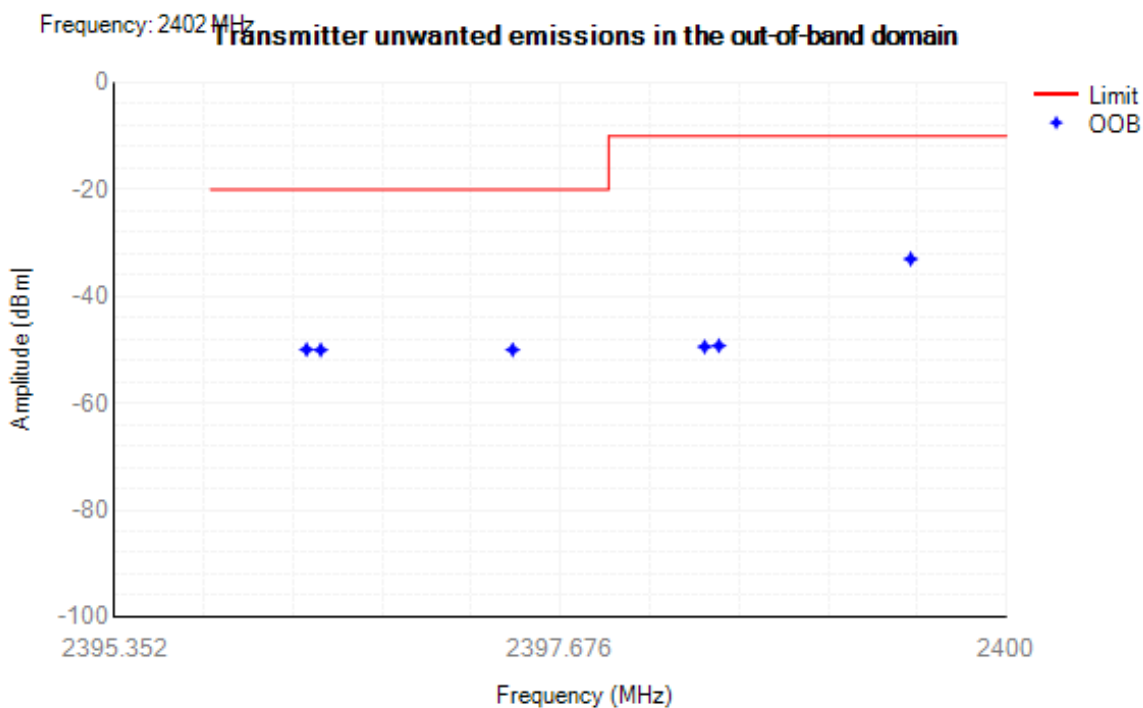

Tx. Emissions OOB NVNT BLE 2M 2480MHz Ant1

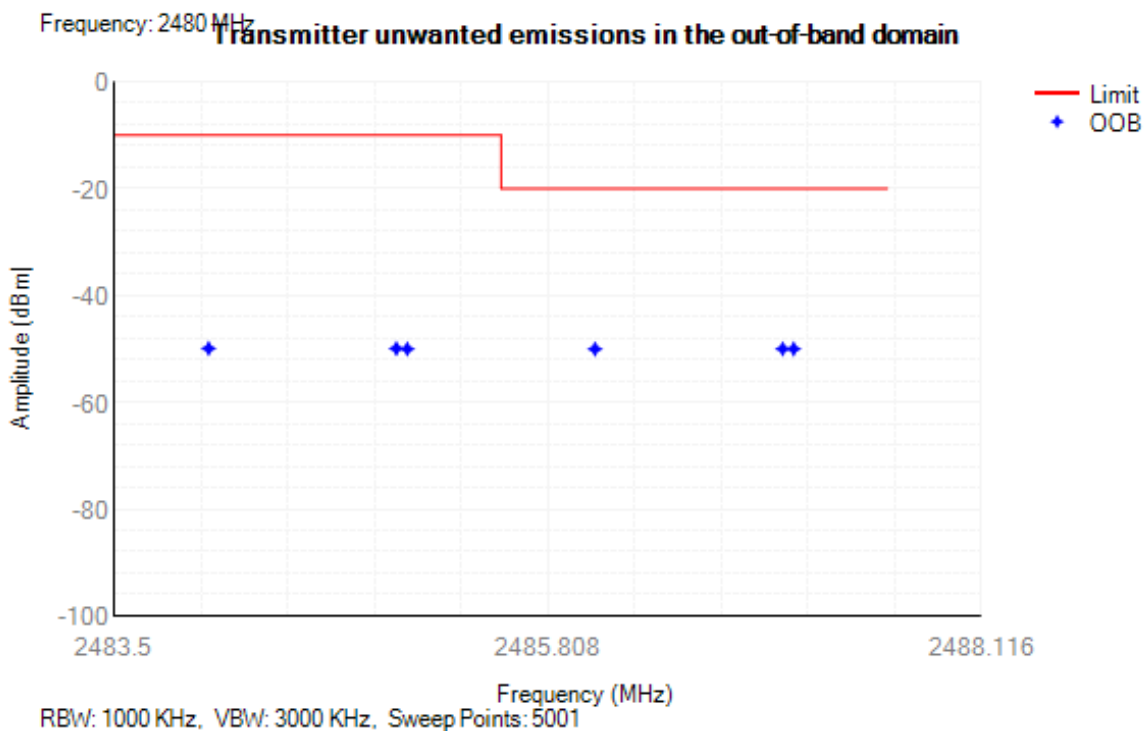

## 8. Transmitter unwanted emissions in the spurious domain

### 8.1. Limit

The transmitter unwanted emissions in the spurious domain shall not exceed the values given in following table .

Frequency range	Maximum power, e.r.p. ( $\leq$ 1 GHz) e.i.r.p. ( $>$ 1 GHz)	Bandwidth
30 MHz to 47 MHz	-36 dBm	100 kHz
47 MHz to 74 MHz	-54 dBm	100 kHz
74 MHz to 87,5 MHz	-36 dBm	100 kHz
87,5 MHz to 118 MHz	-54 dBm	100 kHz
118 MHz to 174 MHz	-36 dBm	100 kHz
174 MHz to 230 MHz	-54 dBm	100 kHz
230 MHz to 470 MHz	-36 dBm	100 kHz
470 MHz to 694 MHz	-54 dBm	100 kHz
694 MHz to 1 GHz	-36 dBm	100 kHz
1 GHz to 12,75 GHz	-30 dBm	1 MHz

### 8.2. Test Procedure

Refer to ETSI EN 300 328 V2.2.2:2019 Clause 5.4.9.

### 8.3. Test Result

Pass

See the next page for test results

## TX Spurious Emissions (Radiated):

1Mbps:

Test Mode: GFSK: CH0 2402MHz					
Frequency (MHz)	Antenna polarization	Result (dBm)	Limit (dBm)	Margin (dB)	Conclusion
94.85	H	-58.28	-54	-4.28	Pass
184.66	H	-66.76	-54	-12.76	Pass
4804.00	H	-56.75	-30	-26.75	Pass
7206.05	H	-58.93	-30	-28.93	Pass
73.80	V	-60.74	-54	-6.74	Pass
178.57	V	-61.94	-54	-7.94	Pass
4803.94	V	-59.79	-30	-29.79	Pass
7206.01	V	-55.40	-30	-25.40	Pass
Test Mode: GFSK: CH39 2480MHz					
90.02	H	-61.55	-54	-7.55	-2.88
726.78	H	-63.26	-36	-27.26	-15.86
4959.76	H	-43.16	-30	-13.16	-27.21
7440.24	H	-55.64	-30	-25.64	-26.46
462.30	V	-51.48	-36	-15.48	-26.54
885.81	V	-47.07	-36	-11.07	-9.55
4960.33	V	-46.26	-30	-16.26	-35.69
7439.65	V	-57.04	-30	-27.04	-24.71
90.02	H	-61.55	-54	-7.55	Pass

2Mbps:

Test Mode: GFSK: CH0 2402MHz					
Frequency (MHz)	Antenna polarization	Result (dBm)	Limit (dBm)	Margin (dB)	Conclusion
100.90	H	-59.33	-54	-5.33	Pass
181.68	H	-68.98	-54	-14.98	Pass
4804.01	H	-52.67	-30	-22.67	Pass
7206.01	H	-55.60	-30	-25.60	Pass
77.54	V	-61.53	-36	-25.53	Pass
183.07	V	-63.54	-54	-9.54	Pass
4803.97	V	-65.04	-30	-35.04	Pass
7206.01	V	-53.65	-30	-23.65	Pass
Test Mode: GFSK: CH39 2480MHz					
89.63	H	-59.12	-54	-5.12	-2.88
729.97	H	-65.51	-36	-29.51	-15.86
4960.35	H	-43.02	-30	-13.02	-27.21
7440.26	H	-53.61	-30	-23.61	-26.46
463.38	V	-49.15	-36	-13.15	-26.54
885.90	V	-44.62	-36	-8.62	-9.55
4959.58	V	-42.71	-30	-12.71	-35.69
7440.41	V	-55.40	-30	-25.40	-24.71
89.63	H	-59.12	-54	-5.12	Pass

## 9. Receiver Spurious emissions

### 9.1. Limit

The spurious emissions of the receiver shall not exceed the values given in following table .

Frequency range	Maximum power, e.r.p. ( $\leq 1$ GHz) e.i.r.p. ( $> 1$ GHz)	Bandwidth
30 MHz to 1GHz	-57 dBm	100 kHz
1 GHz to 12,75 GHz	-47 dBm	1 MHz

### 9.2. Test Procedure

Refer to ETSI EN 300 328 V2.2.2:2019 Clause 5.4.10.

### 9.3. Test Result

Pass

See the next page for test results

## RX Spurious Emissions (Radiated):

1Mbps:

Test Mode: GFSK: CH0 2402MHz					
Frequency (MHz)	Antenna polarization	Result (dBm)	Limit (dBm)	Margin (dB)	Conclusion
88.28	H	-68.82	-57	-11.82	Pass
175.89	H	-64.16	-57	-7.16	Pass
2530.42	H	-64.58	-47	-17.58	Pass
3848.41	H	-68.07	-47	-21.07	Pass
99.69	V	-67.70	-57	-10.70	Pass
200.80	V	-70.73	-57	-13.73	Pass
2551.68	V	-59.69	-47	-12.69	Pass
3849.96	V	-57.76	-47	-10.76	Pass
Test Mode: GFSK: CH39 2480MHz					
85.49	H	-64.68	-57	-7.68	Pass
201.03	H	-62.97	-57	-5.97	Pass
2536.45	H	-55.60	-47	-8.60	Pass
3844.40	H	-62.14	-47	-15.14	Pass
87.89	V	-65.85	-57	-8.85	Pass
189.47	V	-68.80	-57	-11.80	Pass
2539.91	V	-54.94	-47	-7.94	Pass
3850.61	V	-55.89	-47	-8.89	Pass

*Remark: This Report only show the test plots of the worst case.*

## 10. Receiver Blocking

### 10.1. Limit

While maintaining the minimum performance criteria as defined in clause 4.3.2.11.3, the blocking levels at specified frequency offsets shall be equal to or greater than the limits defined for the applicable receiver category provided in table 14, table 15 or table 16.

**Table 14: Receiver Blocking parameters for Receiver Category 1 equipment**

Wanted signal mean power from companion device (dBm) (see notes 1 and 4)	Blocking signal frequency (MHz)	Blocking signal power (dBm) (see note 4)	Type of blocking signal
(-133 dBm + 10 × log <sub>10</sub> (OCBW)) or -68 dBm whichever is less (see note 2)	2380 2504	-34	CW
(-139 dBm + 10 × log <sub>10</sub> (OCBW)) or -74 dBm whichever is less (see note 3)	2 300 2 330 2 360 2 524 2 584 2 674		

NOTE 1: OCBW is in Hz.

NOTE 2: In case of radiated measurements using a companion device and the level of the wanted signal from the companion device cannot be determined, a relative test may be performed using a wanted signal up to  $P_{min} + 26$  dB where  $P_{min}$  is the minimum level of wanted signal required to meet the minimum performance criteria as defined in clause 4.3.1.12.3 in the absence of any blocking signal.

NOTE 3: In case of radiated measurements using a companion device and the level of the wanted signal from the companion device cannot be determined, a relative test may be performed using a wanted signal up to  $P_{min} + 20$  dB where  $P_{min}$  is the minimum level of wanted signal required to meet the minimum performance criteria as defined in clause 4.3.1.12.3 in the absence of any blocking signal.

NOTE 4: The level specified is the level at the UUT receiver input assuming a 0 dBi antenna assembly gain. In case of conducted measurements, this level has to be corrected for the (in-band) antenna assembly gain (G). In case of radiated measurements, this level is equivalent to a power flux density (PFD) in front of the UUT antenna with the UUT being configured/positioned as recorded in clause 5.4.3.2.2.

**Table 15: Receiver Blocking parameters receiver Category 2 equipment**

Wanted signal mean power from companion device (dBm) (see notes 1 and 4)	Blocking signal frequency (MHz)	Blocking signal power (dBm) (see note 4)	Type of blocking signal
$(-139 \text{ dBm} + 10 \times \log_{10}(\text{OCBW}) + 10 \text{ dB})$ or $(-74 + 10 \text{ dB}) \text{ dBm}$ whichever is less (see note 2)	2 380 2 504 2 300 2 584	-34	CW
NOTE 1: OCBW is in Hz.			
NOTE 2: In case of radiated measurements using a companion device and the level of the wanted signal from the companion device cannot be determined, a relative test may be performed using a wanted signal up to $P_{\text{min}} + 26 \text{ dB}$ where $P_{\text{min}}$ is the minimum level of wanted signal required to meet the minimum performance criteria as defined in clause 4.3.1.12.3 in the absence of any blocking signal.			
NOTE 3: The level specified is the level at the UUT receiver input assuming a 0 dBi antenna assembly gain. In case of conducted measurements, this level has to be corrected for the (in-band) antenna assembly gain (G). In case of radiated measurements, this level is equivalent to a power flux density (PFD) in front of the UUT antenna with the UUT being configured/positioned as recorded in clause 5.4.3.2.2.			

**Table 16: Receiver Blocking parameters receiver Category 3 equipment**

Wanted signal mean power from companion device (dBm) (see notes 1 and 4)	Blocking signal frequency (MHz)	Blocking signal power (dBm) (see note 4)	Type of blocking signal
$(-139 \text{ dBm} + 10 \times \log_{10}(\text{OCBW}) + 20 \text{ dB})$ or $(-74 + 20 \text{ dB}) \text{ dBm}$ whichever is less (see note 2)	2 380 2 504 2 300 2 584	-34	CW
NOTE 1: OCBW is in Hz.			
NOTE 2: In case of radiated measurements using a companion device and the level of the wanted signal from the companion device cannot be determined, a relative the test may be performed using a wanted signal up to $P_{\text{min}} + 30 \text{ dB}$ where $P_{\text{min}}$ is the minimum level of wanted signal required to meet the minimum performance criteria as defined in clause 4.3.1.12.3 in the absence of any blocking signal.			
NOTE 3: The level specified is the level at the UUT receiver input assuming a 0 dBi antenna assembly gain. In case of conducted measurements, this level has to be corrected for the (in-band) antenna assembly gain (G). In case of radiated measurements, this level is equivalent to a power flux density (PFD) in front of the UUT antenna with the UUT being configured/positioned as recorded in clause 5.4.3.2.2.			

## 10.2. Test Setup

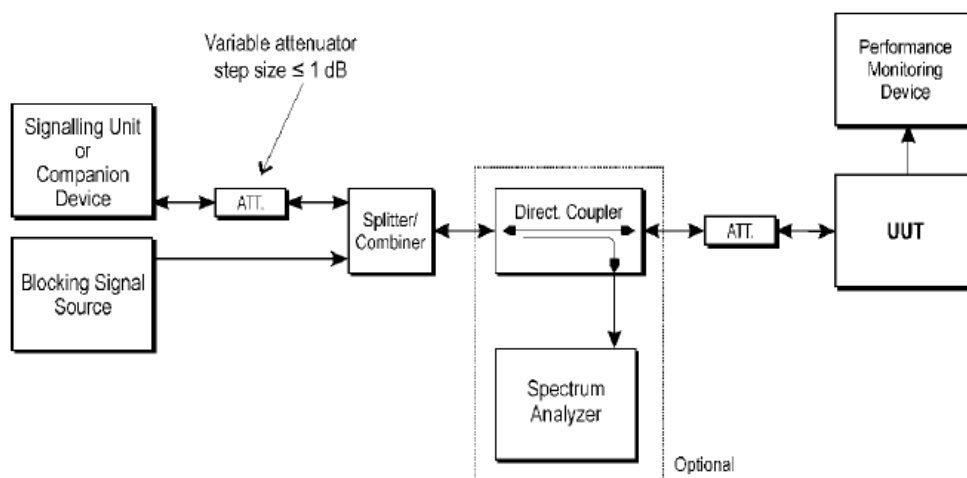

## 10.3. Test Procedure

Refer to ETSI EN 300 328 V2.2.2:2019 Clause 5.4.11.

## 10.4. Test Result

Wanted signal mean power from companion device (dBm)	Channel frequency (MHz)	Blocking signal frequency (MHz)	Blocking signal power (dBm)	PER (%)	PER limit
-69	2402	2380	-34	0.9	$\leq 10\%$
	2402	2504		1.4	$\leq 10\%$
	2402	2300		1.6	$\leq 10\%$
	2402	2584		2.0	$\leq 10\%$
-69	2480	2380		1.7	$\leq 10\%$
	2480	2504		1.2	$\leq 10\%$
	2480	2300		2.5	$\leq 10\%$
	2480	2584		1.9	$\leq 10\%$

Test result: Pass

Note:

- The equipment belongs to receiver category 2 and it shall be tested operating at Lowest channel and highest channel.
- Wanted signal mean power(dBm)=  $(-139 \text{ dBm} + 10 \times \log_{10}(\text{OCBW}) + 10 \text{ dB})$  or  $(-74 + 10 \text{ dB})$  dBm whichever is less whichever is less
- When required blocking signals injected, communication link between the UUT and the associated companion device remains, and the performance still meet the minimum performance criterion  $\text{PER} \leq 10\%$ .

## **11. Geo-location capability**

### **11.1. Definition**

Geo-location capability is a feature of the equipment to determine its geographical location with the purpose to configure itself according to the regulatory requirements applicable at the geographical location where it operates.

The geo-location capability may be present in the equipment or in an external device (temporary) associated with the equipment operating at the same geographical location during the initial power up of the equipment. The geographical location may also be available in equipment already installed and operating at the same geographical location.

### **11.2. Requirements**

The geographical location determined by the equipment shall not be accessible to the user.

### **11.3. Test Result**

Not apply.

This requirement only applies to equipment with geo-location capability. And this product does not have the Geo-location capability, thus, not apply to this product.

## 12. Photos of test setup



### **13. Photos of EUT**

Please refer to the report A2503316-C01-R01.

**14. Model list**

YG691	YG231	YG281	YG291	YG351	YG331
YG361	YG371	YG381	YG391	YG411	YG421
YG431	YG461	YG471	YG491	YG551	YG561
YG581	YG591	YG621	YG621miniYG631	YG651	YG661
YG681	YG721	YG731	YG751	YG761	YG771
YG781	YG791	YG280	YG290	YG330	YG350
YG360	YG370	YG380	YG390	YG420	YG430
YG470	YG490	YG550	YG560	YG600	YG600Plus
YG620mini	YG650	YG680	YG690	YG720	YG730
YG750	YG760	YG770	YG780	YG790	W1K
.YG201	YG203	YG210	YG211	YG213	YG221
YG223	YG233	YG241	YG243	YG251	YG253
YG261	YG263	YG271	YG273	YG283	YG293
YG301	YG303	YG311	YG313	YG321	YG323
YG333	YG341	YG343	YG351	YG353	YG363
YG373	YG383	YG393	YG401	YG403	YG413
YG423	YG433	YG441	YG443	YG451	YG453
YG463	YG473	YG481	YG483	YG493	YG501
YG501	YG511	YG513	YG521	YG523	YG531
YG533	YG541	YG543	YG553	YG563	YG571
YG573	YG583	YG593			

-----END OF REPORT-----