



ETSI EN 300 328 RADIO TEST REPORT

On Behalf of

Shenzhen Shadow Crown Technology Co., Ltd.

LED Projector

Model No.: See model list

Prepared for : Shenzhen Shadow Crown Technology Co., Ltd.
Address : 501-702, Building A9, Longwangmiao Industrial Building, East
Baishixia Community, Fuyong Street, Baoan District, Shenzhen

Prepared By : Shenzhen Alpha Product Testing Co., Ltd.
Address : Building i, No.2, Lixin Road, Fuyong Street, Bao'an District, 518103,
Shenzhen, Guangdong, China

Report Number : A2503316-C01-R02
Date of Receipt : January 4, 2024
Date of Test : January 4, 2024 – February 22, 2024
Date of Report : April 3, 2025
Version Number : V0
Test Result : Pass

TABLE OF CONTENTS

Description	Page
1. General Information	6
1.1. Description of Device (EUT)	6
1.2. Categorization	10
1.3. Accessories of device (EUT)	10
1.4. Ancillary equipment Details	10
1.5. Test Lab information	10
2. Summary of test	11
2.1. Test Standard description:	11
2.2. Summary of test result	11
2.3. Block Diagram of Configuration for test	12
2.4. Test mode	12
2.5. Test Conditions	12
2.6. Measurement Uncertainty (95% confidence levels, k=2)	12
2.7. Test Equipment	13
3. RF output power	15
3.1. Limit	15
3.2. Test Setup	15
3.3. Test Procedure	15
3.4. Test Result	16
4. Power Spectral Density	17
4.1. Limit	17
4.2. Test Setup	17
4.3. Test Procedure	17
4.4. Test Result	17
5. Adaptivity	24
5.1. Limit	24
5.2. Test Setup	24
5.3. Test Procedure	25
5.4. Test Result	25
6. Occupied Channel Bandwidth	38
6.1. Limit	38
6.2. Test Setup	38
6.3. Test Procedure	38
6.4. Test Result	39
7. Transmitter unwanted emissions in the out-of-band domain	46
7.1. Limit	46
7.2. Test Setup	46
7.3. Test Procedure	46
7.4. Test Result	47
8. Transmitter unwanted emissions in the spurious domain	57
8.1. Limit	57
8.2. Test Procedure	57
8.3. Test Result	57
9. Receiver Spurious emissions	60
9.1. Limit	60
9.2. Test Procedure	60
9.3. Test Result	60
10. Receiver Blocking	61
10.1. Limit	61
10.2. Test Setup	62
10.3. Test Procedure	62
10.4. Test Result	63
11. Geo-location capability	64
11.1. Definition	64
11.2. Requirements	64
11.3. Test Result	64
12. Photos of test setup	65

13. Photos of EUT 66
14. Model list..... 67

TEST REPORT DECLARATION

Applicant : Shenzhen Shadow Crown Technology Co., Ltd.
Address : 501-702, Building A9, Longwangmiao Industrial Building, East Baishixia Community, Fuyong Street, Baoan District, Shenzhen
Manufacturer : Shenzhen Shadow Crown Technology Co., Ltd.
Address : 501-702, Building A9, Longwangmiao Industrial Building, East Baishixia Community, Fuyong Street, Baoan District, Shenzhen
EUT Description : LED Projector
(A) Model No. : See model list
(B) Trademark : N/A

Measurement Standard Used:
ETSI EN 300 328 V2.2.2:2019

The device described above is tested by Shenzhen Alpha Product Testing Co., Ltd. The measurement results are contained in this test report and Shenzhen Alpha Product Testing Co., Ltd. is assumed full of responsibility for the accuracy and completeness of these measurements. Also, this report shows that the EUT (Equipment Under Test) is technically compliant with the EN 300 328 requirements.

This report applies to above tested sample only. This report shall not be reproduced in parts without written approval of Shenzhen Alpha Product Testing Co., Ltd.

Tested by (name + signature).....: Yannis Wen
Project Engineer

Approved by (name + signature).....: Jack Xu
Project Manager

Date of issue.....: April 3, 2025



Revision History

Revision	Issue Date	Revisions	Revised By
V0	April 3, 2025	Initial released Issue	Yannis Wen

1. General Information

1.1. Description of Device (EUT)

EUT Name	: LED Projector
Model No.	: See model list
DIFF.	: There is no difference between the models except the appearance color. So all the test were performed on the model YG691.
Power supply	: AC 230V/50Hz
Radio Technology	: 2.4G WIFI
Operation frequency	: 2412MHz-2472MHz for IEEE 802.11 b, g, n/HT20 2422MHz-2462MHz for IEEE 802.11 n/HT40
Channel No.	: 802.11b/802.11g /802.11n(HT20): 13CH 802.11(HT40): 9CH
Modulation type	: IEEE 802.11b: DSSS(CCK,DQPSK,DBPSK) IEEE 802.11g: OFDM(64QAM, 16QAM, QPSK, BPSK) IEEE 802.11n :OFDM(64QAM, 16QAM, QPSK, BPSK)
Antenna Type	: Internal antenna, Maximum Gain is 0dBi. (Antenna information is provided by applicant.)
Software version	: V1.0
Hardware version	: V1.0
Intend use environment	: Residential, commercial and light industrial environment

This Co-license is based on report A2312177-C01-R04, the new models YG201, YG203, YG210, YG211, YG213, YG221, YG223, YG233, YG241, YG243, YG251, YG253, YG261, YG263, YG271, YG273, YG283, YG293, YG301, YG303, YG311, YG313, YG321, YG323, YG333, YG341, YG343, YG351, YG353, YG363, YG373, YG383, YG393, YG401, YG403, YG413, YG423, YG433, YG441, YG443, YG451, YG453, YG463, YG473, YG481, YG483, YG493, YG501, YG501, YG511, YG513, YG521, YG523, YG531, YG533, YG541, YG543, YG553, YG563, YG571, YG573, YG583, YG593 in Co-license are the same as original models YG691, YG231, YG281, YG291, YG351, YG331, YG361, YG371, YG381, YG391, YG411, YG421, YG431, YG461, YG471, YG491, YG551, YG561, YG581, YG591, YG621, YG621mini, YG631, YG651, YG661, YG681, YG721, YG731, YG751, YG761, YG771, YG781, YG791, YG280, YG290, YG330, YG350, YG360, YG370, YG380, YG390, YG420, YG430, YG470, YG490, YG550, YG560, YG600, YG600Plus, YG620mini, YG650, YG680, YG690, YG720, YG730, YG750, YG760, YG770, YG780, YG790, W1K mentioned in test report A2312177-C01-R04 except for the address of the license holder "501-702, Building A9, Longwangmiao Industrial Building, East Baishixia Community, Fuyong Street, Baoan District, Shenzhen", no further test need.

a) The type of modulation used by the equipment:

- FHSS
- other forms of modulation

b) In case of FHSS modulation:

- In case of non-Adaptive Frequency Hopping equipment:
The number of Hopping Frequencies:
- In case of Adaptive Frequency Hopping Equipment:
The maximum number of Hopping Frequencies:
The minimum number of Hopping Frequencies:
The Dwell Time:
The Minimum Channel Occupation Time:

c) Adaptive / non-adaptive equipment:

- non-adaptive Equipment
- adaptive Equipment without the possibility to switch to a non-adaptive mode
- adaptive Equipment which can also operate in a non-adaptive mode

d) In case of adaptive equipment:

- The Channel Occupancy Time implemented by the equipment:
- The equipment has implemented an LBT based DAA mechanism
 - In case of equipment using modulation different from FHSS:
 - The equipment is Frame Based equipment
 - The equipment is Load Based equipment
 - The equipment can switch dynamically between Frame Based and Load Based equipment
 - The CCA time implemented by the equipment: μ s
The value q as referred to in clause 4.3.2.5.2.2.2
 - The equipment has implemented a non-LBT based DAA mechanism
 - The equipment can operate in more than one adaptive mode

e) In case of non-adaptive Equipment:

- The maximum RF Output Power (e.i.r.p.):
- The maximum (corresponding) Duty Cycle: ... %
- Equipment with dynamic behaviour, that behaviour is described here. (e.g. the different combinations of duty cycle and corresponding power levels to be declared):

f) The worst case operational mode for each of the following tests:

- RF Output Power
DSSS
- Power Spectral Density
DSSS
- Duty cycle, Tx-Sequence, Tx-gap
DSSS: Duty cycle 99%
- Dwell time, Minimum Frequency Occupation & Hopping Sequence (only for FHSS equipment)
- Hopping Frequency Separation (only for FHSS equipment)
- Medium Utilisation
-
- Adaptivity & Receiver Blocking
-
- Occupied Channel Bandwidth
DSSS
- Transmitter unwanted emissions in the OOB domain
DSSS
- Transmitter unwanted emissions in the spurious domain
DSSS

- Receiver spurious emissions
DSSS

g) The different transmit operating modes (tick all that apply):

- Operating mode 1: Single Antenna Equipment
 - Equipment with only 1 antenna
 - Equipment with 2 diversity antennas but only 1 antenna active at any moment in time
 - Smart Antenna Systems with 2 or more antennas, but operating in a (legacy) mode where only 1 antenna is used. (e.g. IEEE 802.11™ [i.3] legacy mode in smart antenna systems)
 - Operating mode 2: Smart Antenna Systems - Multiple Antennas without beam forming
 - Single spatial stream / Standard throughput / (e.g. IEEE 802.11™ [i.3] legacy mode)
 - High Throughput (> 1 spatial stream) using Occupied Channel Bandwidth 1
 - High Throughput (> 1 spatial stream) using Occupied Channel Bandwidth 2
- NOTE: Add more lines if more channel bandwidths are supported.
- Operating mode 3: Smart Antenna Systems - Multiple Antennas with beam forming
 - Single spatial stream / Standard throughput (e.g. IEEE 802.11™ [i.3] legacy mode)
 - High Throughput (> 1 spatial stream) using Occupied Channel Bandwidth 1
 - High Throughput (> 1 spatial stream) using Occupied Channel Bandwidth 2
- NOTE: Add more lines if more channel bandwidths are supported.

h) In case of Smart Antenna Systems:

- The number of Receive chains:
- The number of Transmit chains:
- symmetrical power distribution
- asymmetrical power distribution

In case of beam forming, the maximum beam forming gain:

NOTE: Beam forming gain does not include the basic gain of a single antenna.

i) Operating Frequency Range(s) of the equipment:

- Operating Frequency Range 1: 2412 MHz to 2472 MHz
- Operating Frequency Range 2: MHz to MHz
- NOTE: Add more lines if more Frequency Ranges are supported.

j) Occupied Channel Bandwidth(s):

Occupied Channel Bandwidth :

Occupied Channel Bandwidth 2:

NOTE: Add more lines if more channel bandwidths are supported.

k) Type of Equipment (stand-alone, combined, plug-in radio device, etc.):

- Stand-alone
- Combined Equipment (Equipment where the radio part is fully integrated within another type of equipment)
- Plug-in radio device (Equipment intended for a variety of host systems)
- Other

l) The extreme operating conditions that apply to the equipment:

Operating temperature range:

Operating voltage range: AC ■ DC

Details provided are for the: ■ stand-alone equipment

combined (or host) equipment

test jig

m) The intended combination(s) of the radio equipment power settings and one or more antenna assemblies and their corresponding e.i.r.p levels:

- Antenna Type
 - Internal antenna
 - Antenna Gain:dBi
 - If applicable, additional beamforming gain (excluding basic antenna gain):

dB

- Temporary RF connector provided
- No temporary RF connector provided
- Dedicated Antennas (equipment with antenna connector)
 - Single power level with corresponding antenna(s)
 - Multiple power settings and corresponding antenna(s)
 - Number of different Power Levels:
 - Power Level 1: dBm
 - Power Level 2: dBm
 - Power Level 3: dBm

NOTE 1: Add more lines in case the equipment has more power levels.

NOTE 2: These power levels are conducted power levels (at antenna connector).

n) The nominal voltages of the stand-alone radio equipment or the nominal voltages of the combined (host) equipment or test jig in case of plug-in devices:

Details provided are for the: stand-alone equipment

combined (or host) equipment

test jig

Supply Voltage AC mains State AC voltage

DC State DC voltage : V

In case of DC, indicate the type of power source

Internal Power Supply

External Power Supply or AC/DC adapter

Battery:V..

Other:

o) Describe the test modes available which can facilitate testing:

The EUT can be into the Engineer mode for testing

p) The equipment type (e.g. Bluetooth®, IEEE 802.11™ [i.3], proprietary, etc.):

WiFi

q) If applicable, the statistical analysis referred to in clause 5.4.1 q)

Not apply

r) If applicable, the statistical analysis referred to in clause 5.4.1 r)

Not apply

s) Geo-location capability supported by the equipment:

Yes

The geographical location determined by the equipment as defined in clause 4.3.1.13.2

or

clause 4.3.2.12.2 is not accessible to the user

No

t) Describe the minimum performance criteria that apply to the equipment (see clause 4.3.1.12.3 or clause 4.3.2.11.3):

The minimum performance criterion shall be a PER less than or equal to 10 %.

The intended use of the equipment should be in the normal operation without lost the communication link or no unintentionally operation occurs.

1.2. Categorization

Receiver category 1

Adaptive equipment with a maximum RF output power greater than 10 dBm e.i.r.p. shall be considered as receiver category 1 equipment.

Receiver category 2

Non-adaptive equipment with a Medium Utilization (MU) factor greater than 1 % and less than or equal to 10 % or adaptive equipment with a maximum RF output power of 10 Bm e.i.r.p. shall be considered as receiver category 2 equipment.

Receiver category 3

Non-adaptive equipment with a maximum Medium Utilization (MU) factor of 1 % or adaptive equipment with a maximum RF output power of 0 dBm e.i.r.p. shall be considered as receiver category 3 equipment.

1.3. Accessories of device (EUT)

Accessories : /

Manufacturer : /

Model : /

Ratings : /

1.4. Ancillary equipment Details

No.	Description	Manufacturer	Model	Serial Number	Certification or SDOC
1	DC Power	N/A	N/A	N/A	N/A

1.5. Test Lab information

Shenzhen Alpha Product Testing Co., Ltd.

Building i, No.2, Lixin Road, Fuyong Street, Bao'an District,
518103, Shenzhen, Guangdong, China

2. Summary of test

2.1. Test Standard description:

ETSI EN 300 328 V2.2.2:2019: Wideband transmission systems; Data transmission equipment operating in the 2,4 GHz ISM band and using wide band modulation techniques; Harmonised Standard for access to radio spectrum

2.2. Summary of test result

Technical requirements for the equipment using wide band modulations other than FHSS:

The following essential requirements and test specifications are relevant to the presumption of conformity under Article 3.2 of Directive 2014/53/EU			
No	Test Parameter	Clause No	Results
Transmitter Parameters			
1	RF output power	4.3.2.2	PASS
2	Power Spectral Density	4.3.2.3	PASS
3	Duty Cycle, Tx-sequence, Tx-gap	4.3.2.4	N/A
4	Accumulated Transmit time, Frequency Occupation & Hopping Sequence	4.3.1.4	N/A
5	Hopping Frequency Separation	4.3.1.5	N/A
6	Medium Utilisation (MU) factor	4.3.2.5	N/A
7	Adaptivity	4.3.2.6	PASS
8	Occupied Channel Bandwidth	4.3.2.7	PASS
9	Transmitter unwanted emissions in the OOB domain	4.3.2.8	PASS
10	Transmitter unwanted emissions in the spurious domain	4.3.2.9	PASS
Receiver Parameters			
11	Receiver spurious emissions	4.3.2.10	PASS
12	Receiver Blocking	4.3.2.11	PASS
13	Geo-location capability	4.3.2.12	N/A
Note: 1. N/A is an abbreviation for Not Applicable and means this test item is not applicable for this device according to the technology characteristic of device. 2. Decision rules for the conclusion of this test report: decision by actual test data without considering measurement uncertainty.			

2.3. Block Diagram of Configuration for test



2.4. Test mode

The special RF test software was used to control EUT work in Continuous WIFI TX mode, and select test channel, wireless mode.

Mode	Data rate (Mbps)	Channel	Frequency (MHz)
IEEE 802.11b	1	Low :CH1	2412
	1	Middle: CH7	2442
	1	High: CH13	2472
IEEE 802.11g	6	Low :CH1	2412
	6	Middle: CH7	2442
	6	High: CH13	2472
IEEE 802.11n HT20	6.5	Low :CH1	2412
	6.5	Middle: CH7	2442
	6.5	High: CH13	2472
IEEE 802.11n HT40	13.5	Low :CH3	2422
	13.5	Middle: CH7	2442
	13.5	High: CH11	2462

Note1: According exploratory test, EUT will have maximum output power in those data rate, so those data rate were used for all test.

2.5. Test Conditions

	Normal Conditions	Extreme Conditions
Temperature range	15-35°C	-10°C and 45°C
Humidity range	20-75%	20-75%
Pressure range	86-106kPa	86-106kPa
Power supply	AC 230V/50Hz	AC 110V to AC 240V (declared by the manufacturer.)

Note:
 1 The test procedure described in clause 5.1 of EN 300 328 was used for extreme test procedure.
 2 The Extreme Temperature and Extreme Voltages declared by the manufacturer.

2.6. Measurement Uncertainty (95% confidence levels, k=2)

Item	MU	Remark
Uncertainty for Conducted Emission Test	1.63dB	
Uncertainty for Radiation Emission test in 3m chamber (30MHz to 1GHz)	3.74 dB	Polarize: V
	3.76 dB	Polarize: H
Uncertainty for Radiation Emission test in 3m chamber (1GHz to 25GHz)	3.77 dB	Polarize: H
	3.80 dB	Polarize: V
Uncertainty for radio frequency	5.06×10^{-8} GHz	
Uncertainty for conducted RF Power	0.40dB	

2.7. Test Equipment

Equipment	Manufacturer	Model No.	Firmware version	Serial No.	Last cal.	Cal. Due day
Test Receiver	ROHDE&SCHWARZ	ESCI	4.42 SP1	101165	2023.08.16	2024.08.15
Spectrum analyzer	ROHDE&SCHWARZ	FSV40-N	2.3	102137	2023.08.16	2024.08.15
Horn Antenna	SCHWARZBECK	BBHA 9120 D	/	2106	2023.08.19	2024.08.18
Filter	KANGMAI	ZLPF-LDC-100 0- 1959	/	1209002075	2023.08.16	2024.08.15
Filter	WAINWRIGHT	WHKX2.80 /18G- 12SS	/	SN1	2023.08.16	2024.08.15
RF Cable	Resenberger	Cable 4	/	PE1	2023.08.16	2024.08.15
CMU200	ROHDE&SCHWARZ	CMU200	V5.21	116785	2023.08.16	2024.08.15
Signal Analyzer	Agilent	N9020A	A.14.16	MY499100060	2023.08.16	2024.08.15
Vector Signal	Agilent	N5182A	/	MY49060042	2023.08.16	2024.08.15
Vector Signal	Agilent	E4438C	/	US44271917	2023.08.16	2024.08.15
Amplifier	HP	HP8347A	/	2834A00455	2023.08.16	2024.08.15
Amplifier	Agilent	8449B	/	3008A02664	2023.08.16	2024.08.15
Test Receiver	ROHDE&SCHWARZ	ESR	2.28 SP1	1316.3003K03- 102082-Wa	2023.08.16	2024.08.15
Bilog Antenna	SCHWARZBECK	VULB 9168	/	9168-627	2023.08.28	2024.08.27
9*6*6 anechoic	CHENYU	9*6*6	/	N/A	2022.05.17	2025.05.16
RF Cable	Resenberger	Cable 1	/	RE1	2023.08.16	2024.08.15
RF Cable	Resenberger	Cable 2	/	RE2	2023.08.16	2024.08.15
RF Cable	Resenberger	Cable 3	/	CE1	2023.08.16	2024.08.15
Power Sensor	DARE	RPR3006W	/	15100041SNO 91	2023.08.16	2024.08.15
Power Sensor	DARE	RPR3006W	/	15100041SNO 92	2023.08.16	2024.08.15
CMW500	ROHDE&SCHWARZ	CMW500	V 3.7.22	1201.0002K50- 117239-sM	2023.08.16	2024.08.15
Loop Antenna	SCHWARZBECK	FMZB 1519B	/	00128	2023.08.19	2024.08.18
Temp. & Humid. Chamber	Teelong	TL-HW408S	/	TL-20191205-0 1	2023.07.25	2024.07.24
Adjustable attenuator	MWRFtest	N/A	/	N/A	N/A	N/A
10dB Attenuator	Mini-Circuits	DC-6G	/	N/A	N/A	N/A
Horn Antenna	SCHWARZBECK	BBHA9170	/	00946	2023.08.19	2024.08.18
Preamplifier	SKET	LNPA_1840-50	/	SK2018101801	2023.08.16	2024.08.15
AM/FM STEREO	MEGURO	MSG-2280	/	61080249	2023.08.16	2024.08.15

Software Information			
Test Item	Software Name	Manufacturer	Version
RE	EZ-EMC	farad	Alpha-3A1
RF-CE	MTS 8310	MWRFtest	2.0.0.0

3. RF output power

3.1. Limit

The RF output power for non-FHSS equipment shall be equal to or less than 20 dBm.

NOTE: For Non-adaptive FHSS equipment, the manufacturer may have declared a reduced RF Output Power (see clause 5.4.1 m)) and associated Duty Cycle (see clause 5.4.1 e)) that will ensure that the equipment meets the requirement for the Medium Utilization (MU) factor further described in clause 4.3.2.5. This is verified by the conformance test referred to in clause 4.3.2.5.4.

For non-adaptive non-FHSS equipment, where the manufacturer has declared an RF output power of less than 20 dBm e.i.r.p., the RF output power shall be equal to or less than that declared value.

This limit shall apply for any combination of power level and intended antenna assembly.

Limit
20dBm

3.2. Test Setup

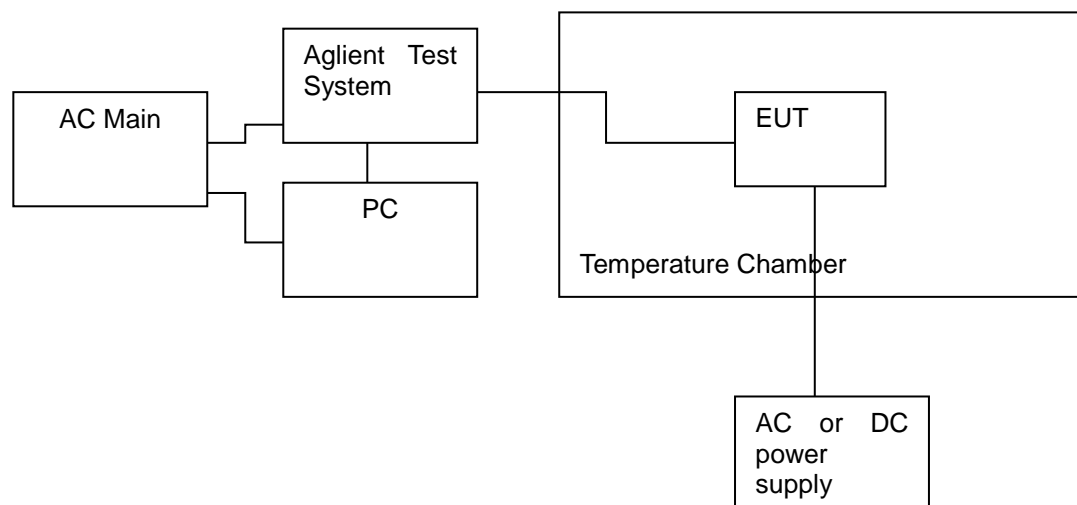

3.3. Test Procedure

Refer to ETSI EN 300 328 V2.2.2:2019 Clause 5.4.2.

3.4. Test Result

Condition	Mode	Frequency (MHz)	Antenna	Max Burst RMS Power (dBm)	Burst Number	Max EIRP (dBm)	Limit (dBm)	Verdict
NVHT	b	2412	Ant1	10.99	16	10.99	20	Pass
NVHT	b	2442	Ant1	10.98	15	10.98	20	Pass
NVHT	b	2472	Ant1	11.19	15	11.19	20	Pass
NVLT	b	2412	Ant1	10.68	16	10.68	20	Pass
NVLT	b	2442	Ant1	11.03	15	11.03	20	Pass
NVLT	b	2472	Ant1	11.01	16	11.01	20	Pass
NVNT	b	2412	Ant1	11.34	16	11.34	20	Pass
NVNT	b	2442	Ant1	11.34	15	11.34	20	Pass
NVNT	b	2472	Ant1	11.24	16	11.24	20	Pass
NVHT	g	2412	Ant1	11.52	26	11.52	20	Pass
NVHT	g	2442	Ant1	11.58	26	11.58	20	Pass
NVHT	g	2472	Ant1	11.5	26	11.5	20	Pass
NVLT	g	2412	Ant1	11.27	26	11.27	20	Pass
NVLT	g	2442	Ant1	11.44	26	11.44	20	Pass
NVLT	g	2472	Ant1	11.74	26	11.74	20	Pass
NVNT	g	2412	Ant1	11.71	27	11.71	20	Pass
NVNT	g	2442	Ant1	11.78	26	11.78	20	Pass
NVNT	g	2472	Ant1	11.51	27	11.51	20	Pass
NVHT	n20	2412	Ant1	11.72	27	11.72	20	Pass
NVHT	n20	2442	Ant1	11.45	26	11.45	20	Pass
NVHT	n20	2472	Ant1	11.59	27	11.59	20	Pass
NVLT	n20	2412	Ant1	11.67	27	11.67	20	Pass
NVLT	n20	2442	Ant1	11.68	26	11.68	20	Pass
NVLT	n20	2472	Ant1	11.86	26	11.86	20	Pass
NVNT	n20	2412	Ant1	11.49	27	11.49	20	Pass
NVNT	n20	2442	Ant1	11.35	26	11.35	20	Pass
NVNT	n20	2472	Ant1	11.64	27	11.64	20	Pass
NVHT	n40	2422	Ant1	11.39	33	11.39	20	Pass
NVHT	n40	2442	Ant1	11.41	32	11.41	20	Pass
NVHT	n40	2462	Ant1	11.41	33	11.41	20	Pass
NVLT	n40	2422	Ant1	11.3	32	11.3	20	Pass
NVLT	n40	2442	Ant1	11.33	32	11.33	20	Pass
NVLT	n40	2462	Ant1	11.49	32	11.49	20	Pass
NVNT	n40	2422	Ant1	11.42	32	11.42	20	Pass
NVNT	n40	2442	Ant1	11.33	32	11.33	20	Pass
NVNT	n40	2462	Ant1	11.4	32	11.4	20	Pass

4. Power Spectral Density

4.1. Limit

The maximum Power Spectral Density for non-FHSS equipment is 10 dBm per MHz.

Limit
10dBm/MHz

4.2. Test Setup

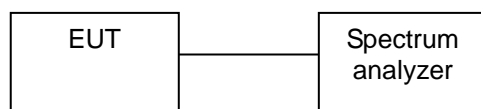

4.3. Test Procedure

Refer to ETSI EN 300 328 V2.2.2:2019 Clause 5.4.3

Connect the UUT to the spectrum analyzer and use the following settings:

Frequency range	2400MHz-2483.5MHz
RBW/VBW	10KHz/30KHz
Sweep points/time	>8350 / 10S
Detector	RMS
Trace	Max hold

4.4. Test Result

Condition	Mode	Frequency (MHz)	Antenna	Max PSD (dBm/MHz)	Limit (dBm/MHz)	Verdict
NVNT	b	2412	Ant1	1.82	10	Pass
NVNT	b	2442	Ant1	1.94	10	Pass
NVNT	b	2472	Ant1	1.8	10	Pass
NVNT	g	2412	Ant1	0.17	10	Pass
NVNT	g	2442	Ant1	0.24	10	Pass
NVNT	g	2472	Ant1	-0.01	10	Pass
NVNT	n20	2412	Ant1	-0.16	10	Pass
NVNT	n20	2442	Ant1	-0.46	10	Pass
NVNT	n20	2472	Ant1	-0.14	10	Pass
NVNT	n40	2422	Ant1	-1.82	10	Pass
NVNT	n40	2442	Ant1	-3.44	10	Pass
NVNT	n40	2462	Ant1	-3.42	10	Pass

PSD NVNT b 2412MHz Ant1

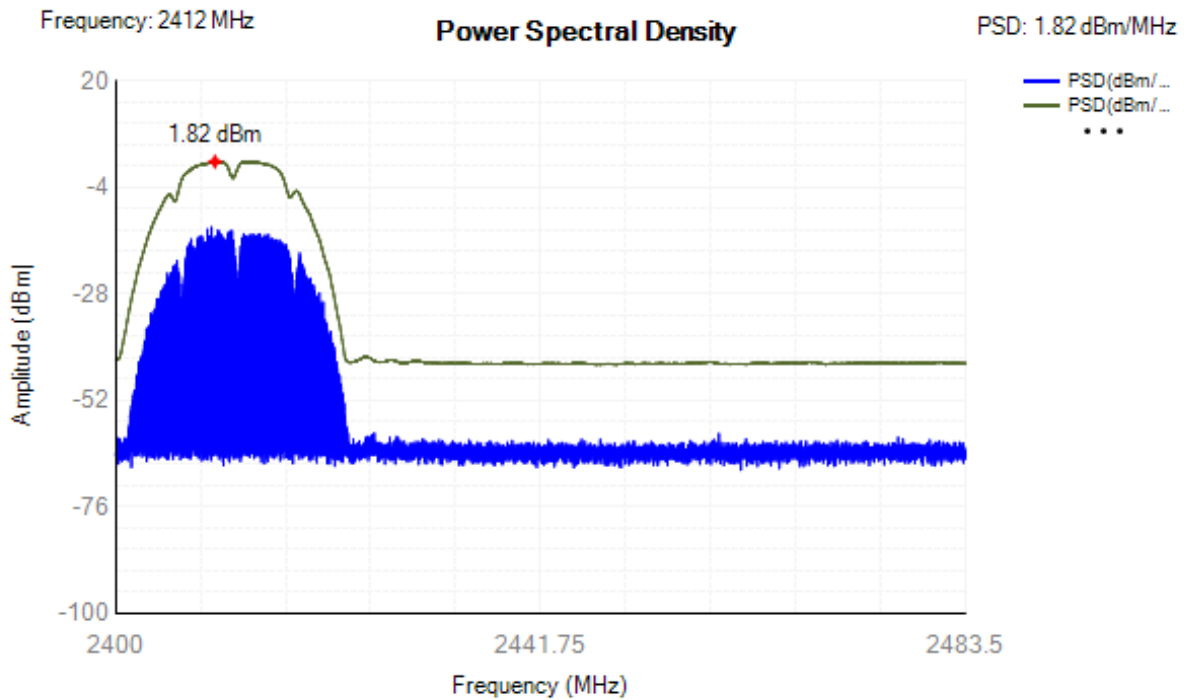

PSD NVNT b 2442MHz Ant1

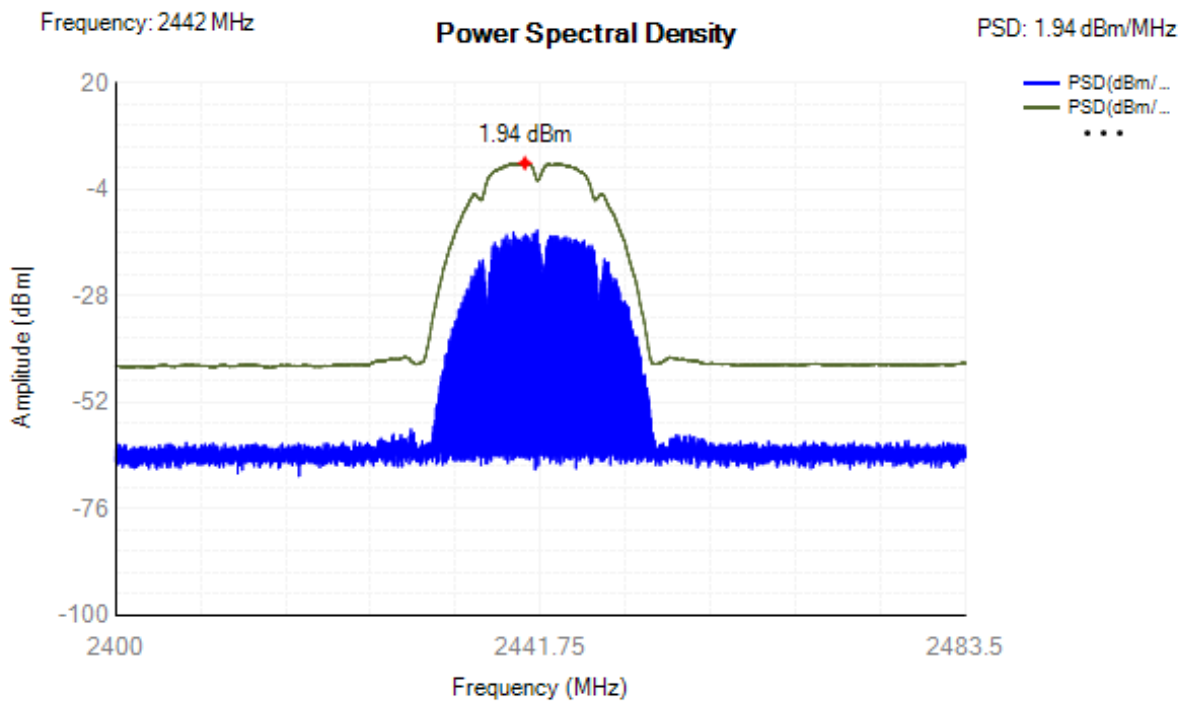

PSD NVNT b 2472MHz Ant1

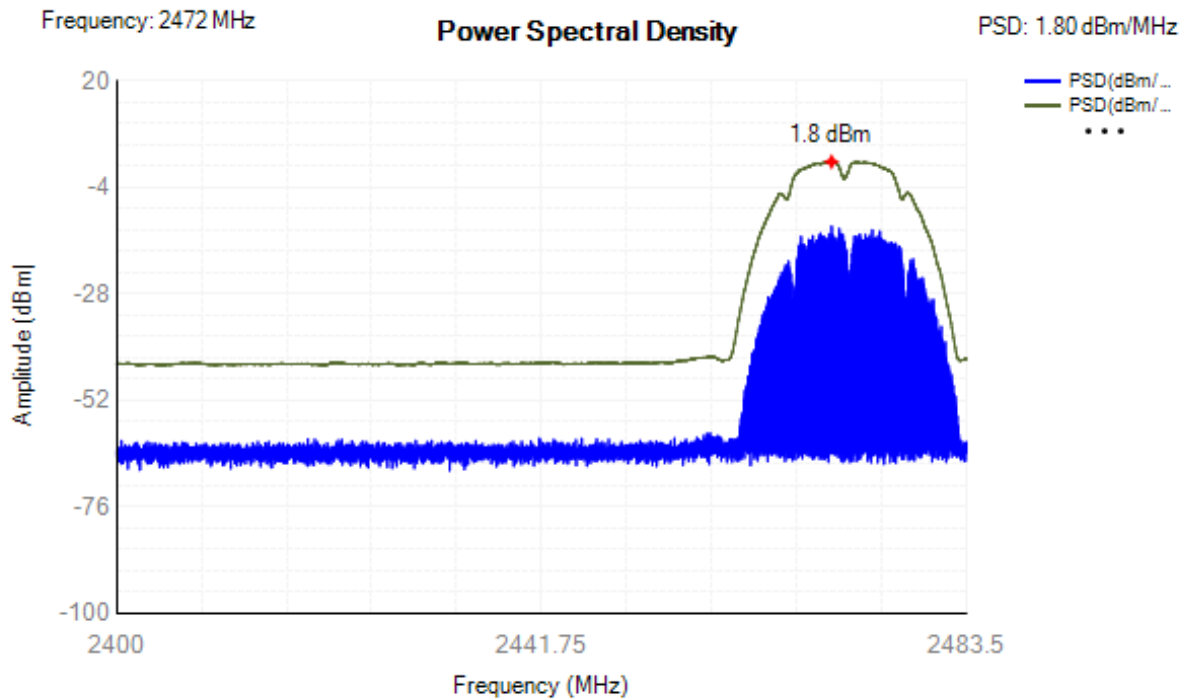

PSD NVNT g 2412MHz Ant1

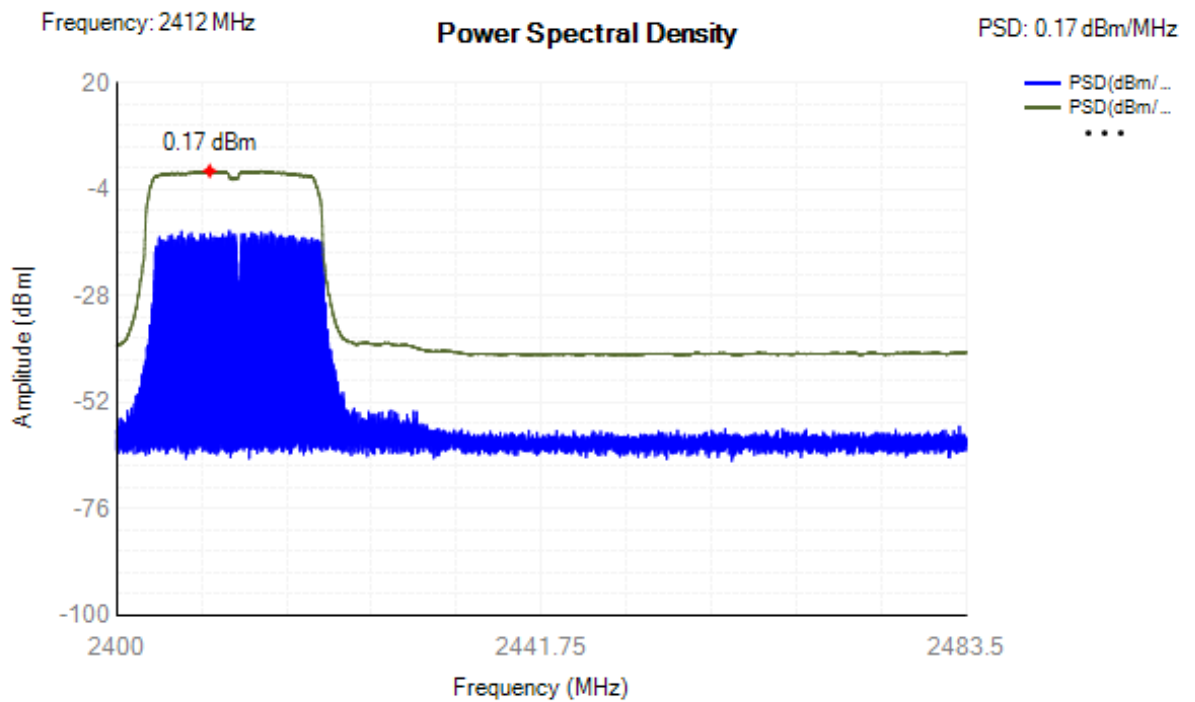

PSD NVNT g 2442MHz Ant1

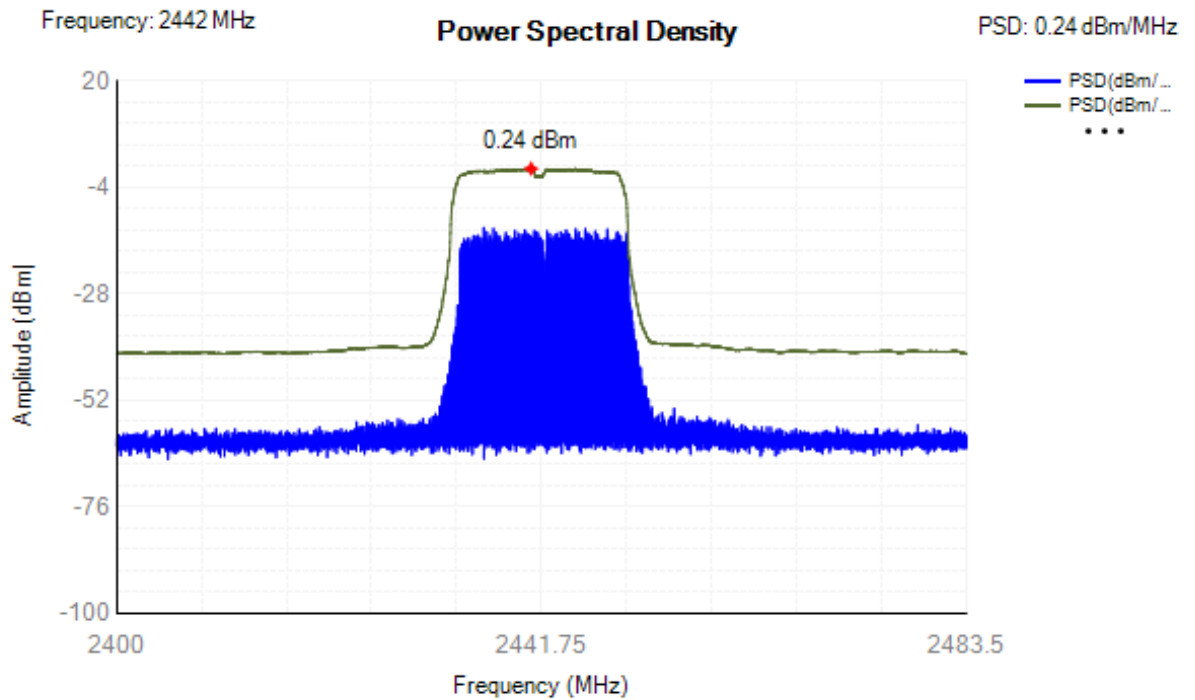

PSD NVNT g 2472MHz Ant1

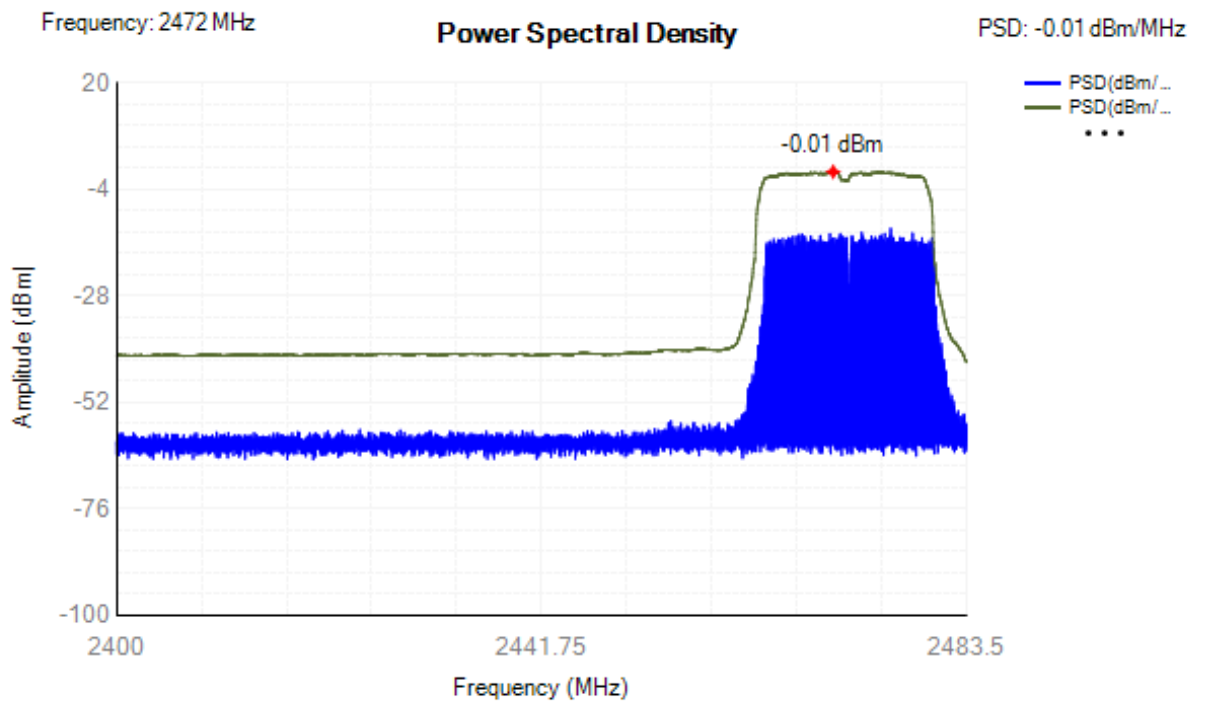

PSD NVNT n20 2412MHz Ant1

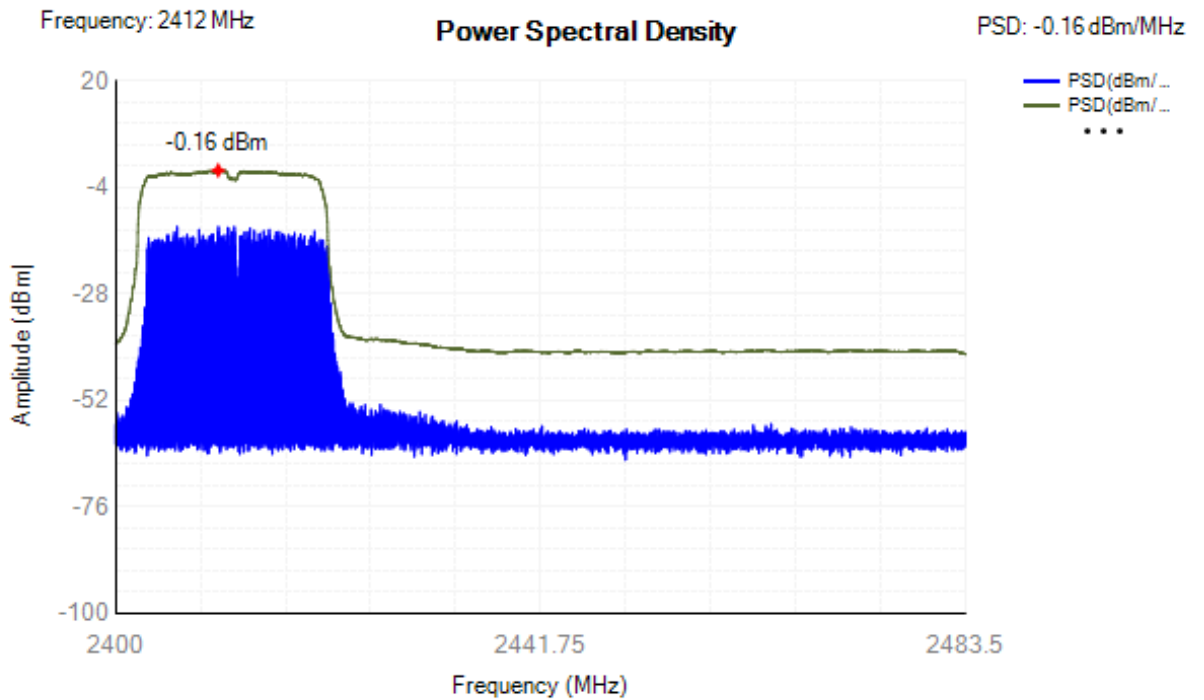

PSD NVNT n20 2442MHz Ant1

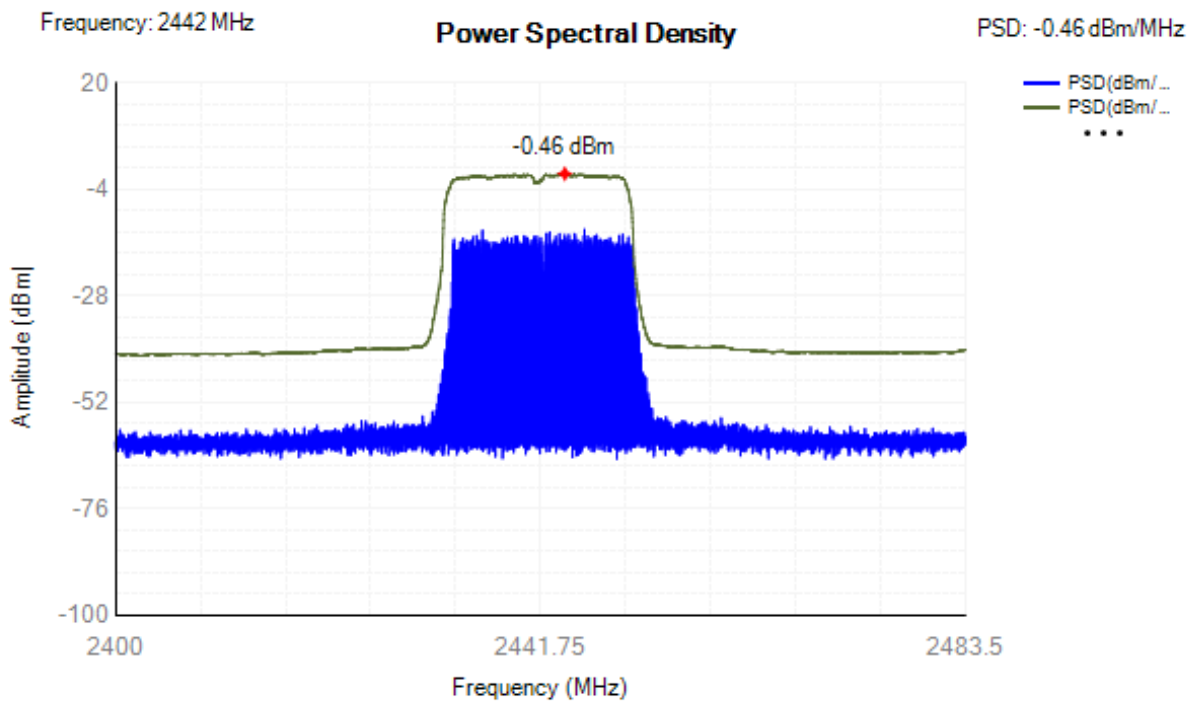

PSD NVNT n20 2472MHz Ant1

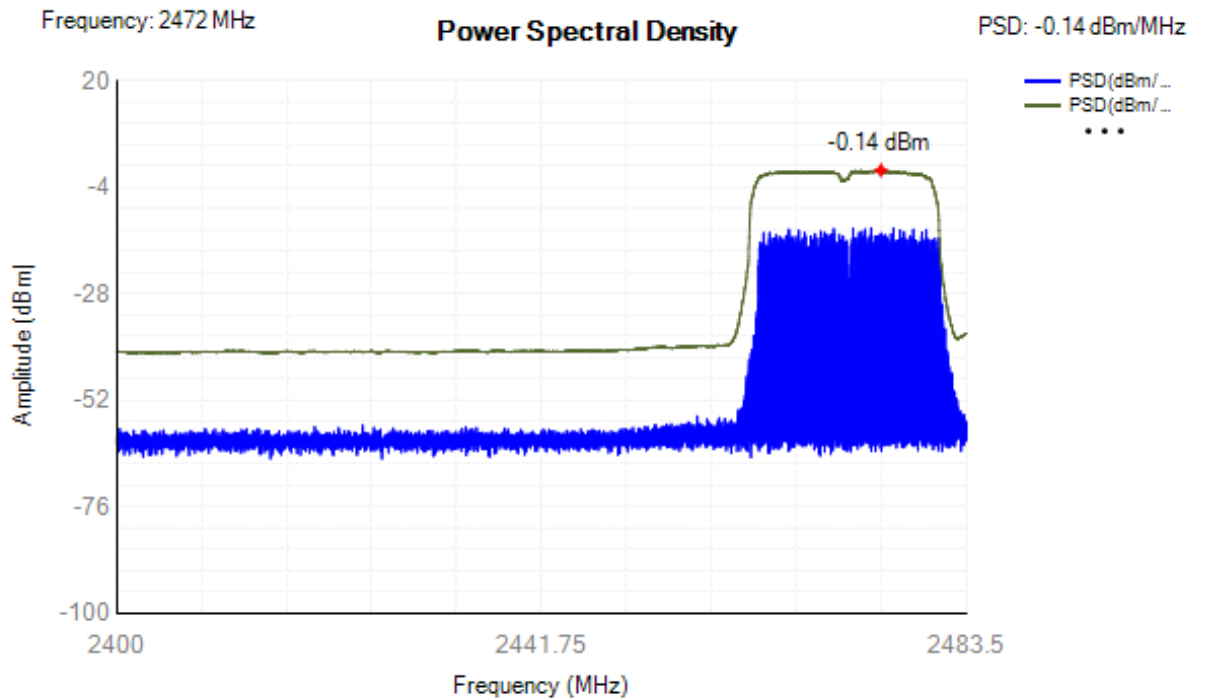

PSD NVNT n40 2422MHz Ant1

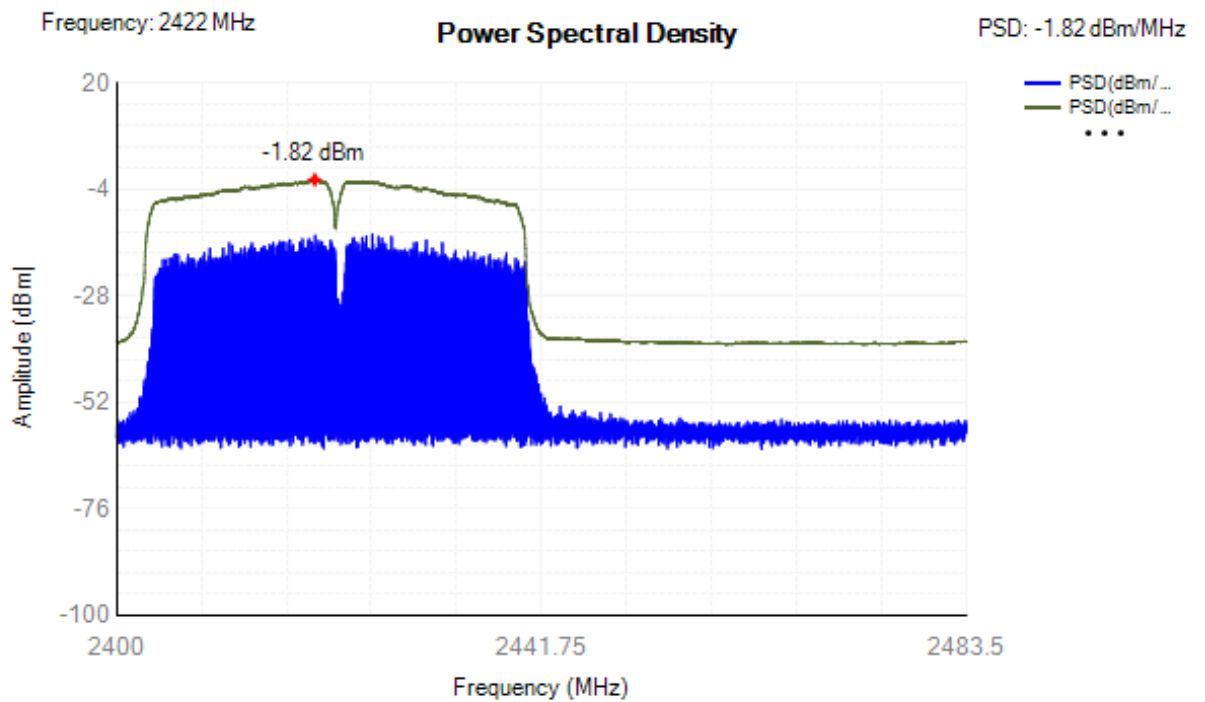

PSD NVNT n40 2442MHz Ant1

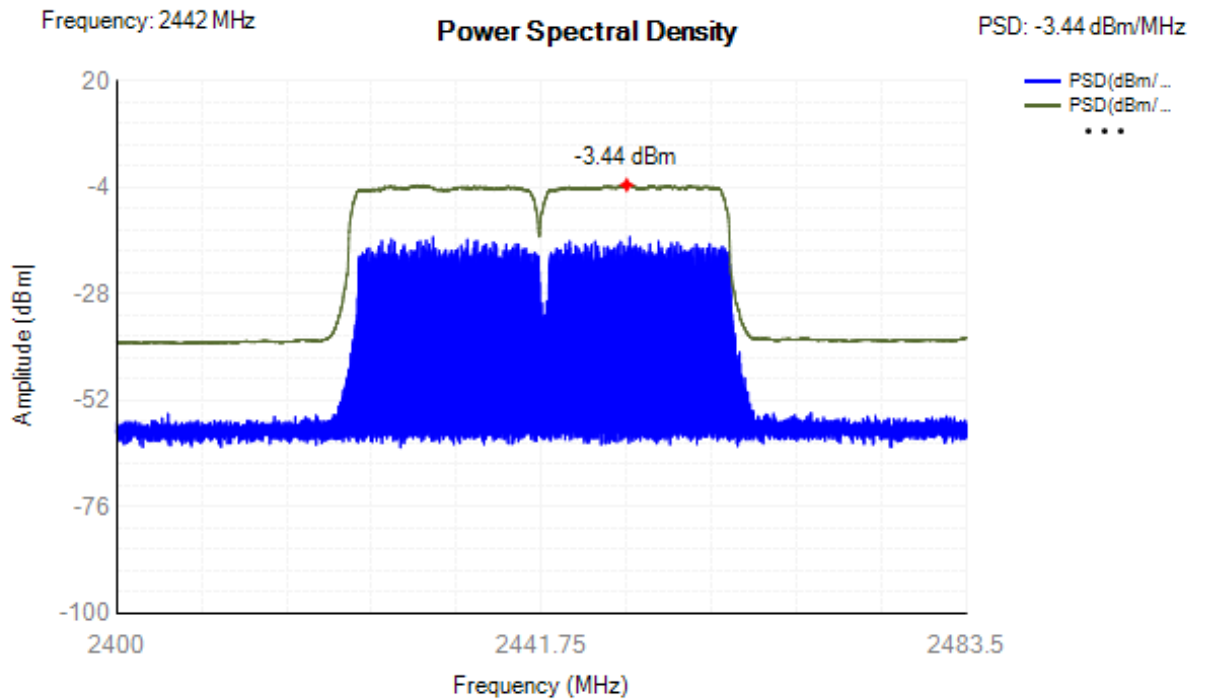

PSD NVNT n40 2462MHz Ant1

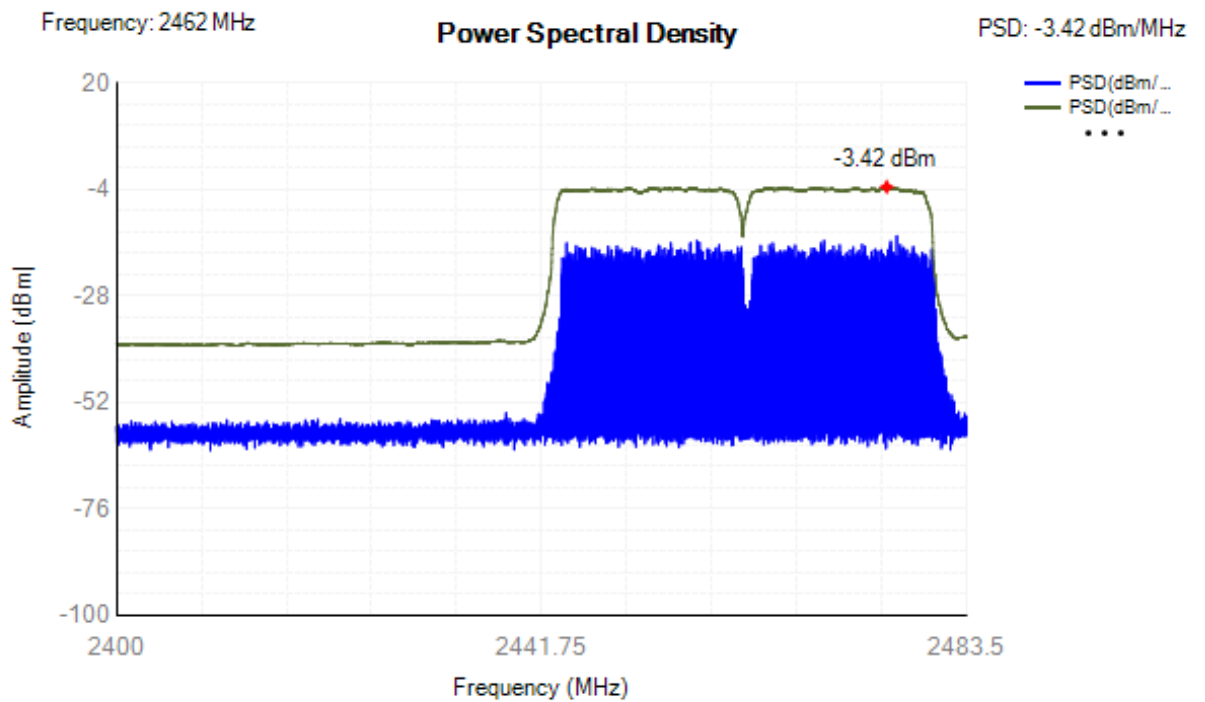

5. Adaptivity

5.1. Limit

The frequency range of the equipment is determined by the lowest and highest

Non-LBT based Detect And Avoid:

1 The hopping frequency shall remain unavailable for a minimum time equal to 1 second or 5 times the actual number of hopping frequencies in the current (adapted) channel map used by the equipment, multiplied with the Channel Occupancy Time whichever is greater. There shall be no transmissions during this silent period on this hopping frequency. After this, the hopping frequency may be considered again as an 'available' frequency.;

2 $COT < 40 \text{ ms}$;

3 Idle Period = 5% of $COT \geq 100 \mu\text{s}$;

4 Detection threshold level = $-70 \text{ dBm/MHz} + 10 \times \log_{10} (100 \text{ mW} / P_{out})$ (P_{out} in mW e.i.r.p.);

LBT based Detect And Avoid (Frame Based Equipment):

1 Minimum Clear Channel Assessment (CCA) time = 18 μs ;

2 CCA observation time declared by the supplier;

3 $COT < 60 \text{ ms}$;

4 Idle Period = 5% of $COT \geq 100 \mu\text{s}$;

5 Detection threshold level = $-70 \text{ dBm/MHz} + 10 \times \log_{10} (100 \text{ mW} / P_{out})$ (P_{out} in mW e.i.r.p.);

Short Control Signalling Transmissions:

Short Control Signalling Transmissions shall have a maximum TxOn / (TxOn + TxOff) ratio of 10% within an observation period of 50ms or within an observation period equal to the dwell time, whichever is less.

5.2. Test Setup

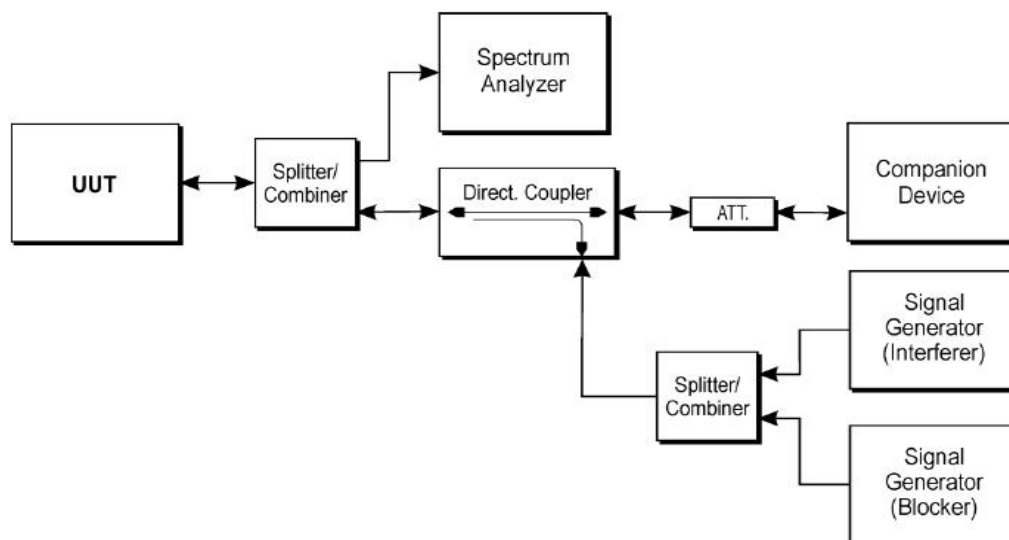

5.3. Test Procedure

Refer to ETSI EN 300 328 V2.2.2:2019 Clause 5.4.6.

5.4. Test Result

Adaptivity									
Condition	Mode	Frequency (MHz)	Antenna	AWGN Level (dBm)	CW Level (dBm)	Short Control Width (ms)	Short Control Ratio(%)	Limit (%)	Verdict
NVNT	b	2412	Ant1	-65	-35	0	0	<=10	Pass
NVNT	b	2472	Ant1	-65	-35	0	0	<=16	Pass
NVNT	g	2412	Ant1	-65	-35	0	0	<=10	Pass
NVNT	g	2472	Ant1	-65	-35	0	0	<=10	Pass
NVNT	n20	2412	Ant1	-60	-35	0	0	<=10	Pass
NVNT	n20	2472	Ant1	-60	-35	0	0	<=10	Pass

Adaptivity NVNT b 2412MHz

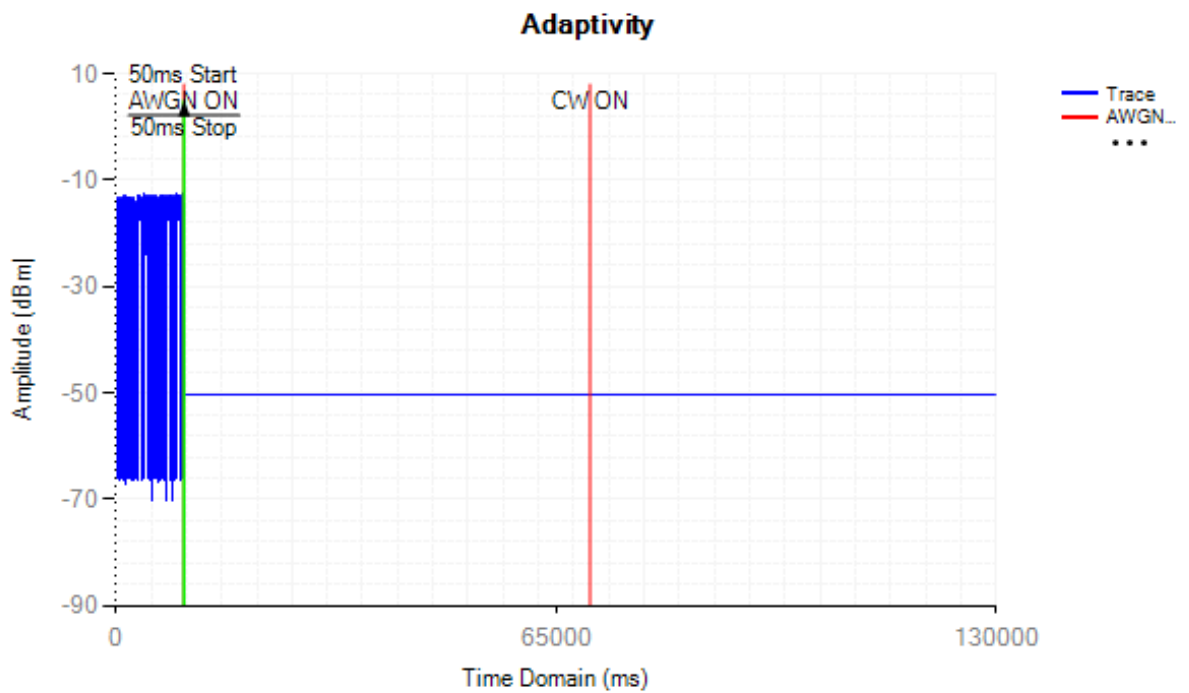

Control Signal NVNT b 2412MHz

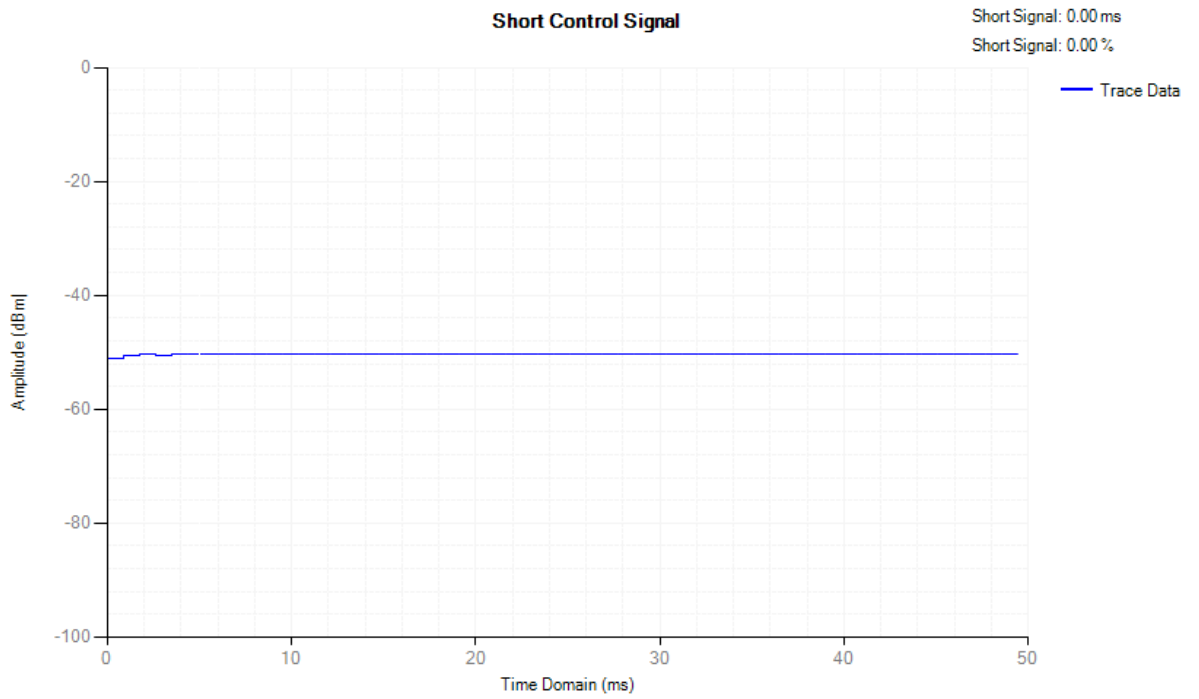

Adaptivity NVNT b 2472MHz

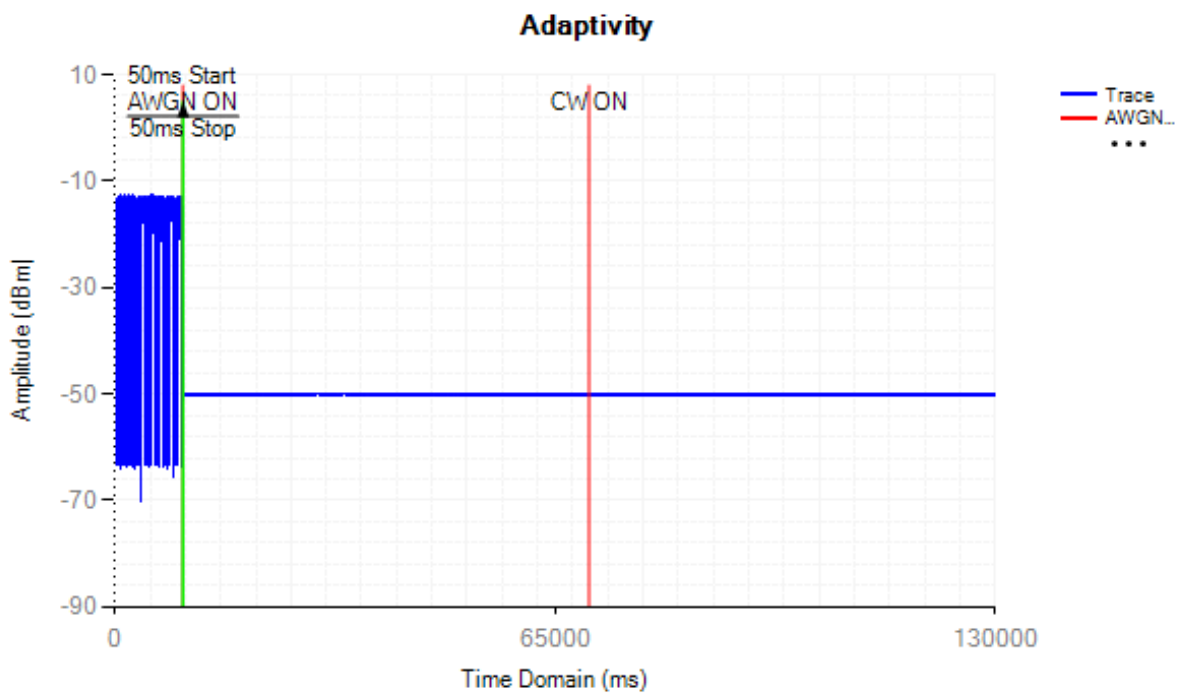

Control Signal NVNT b 2472MHz

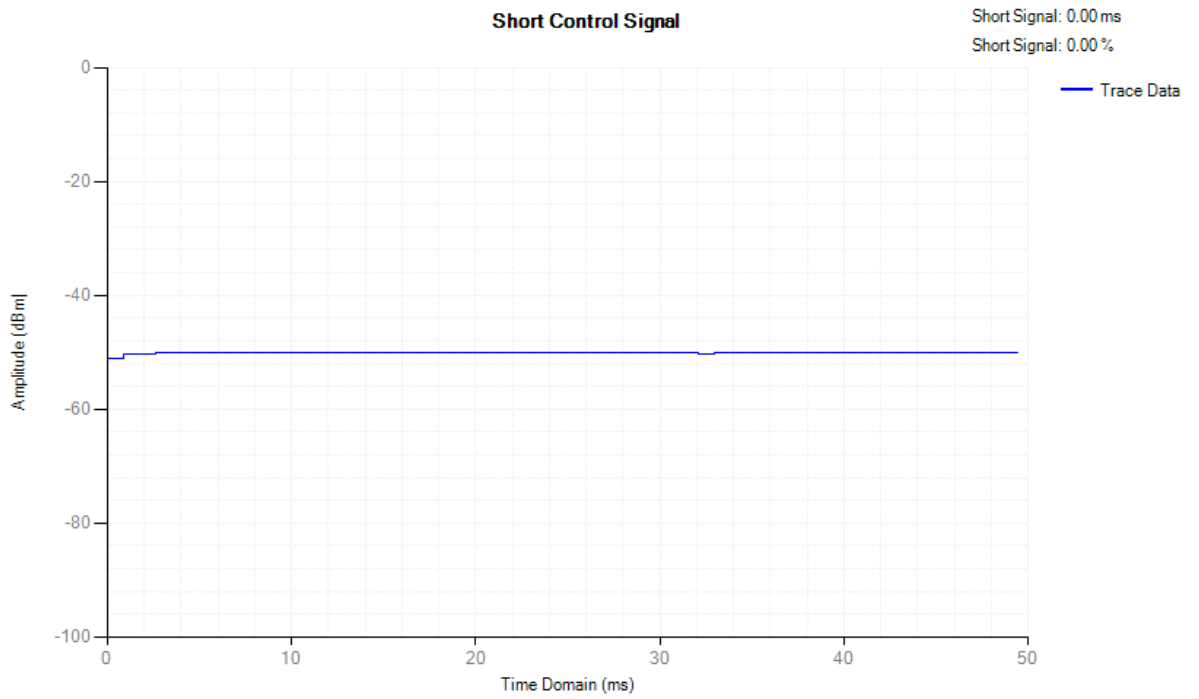

Adaptivity NVNT g 2412MHz

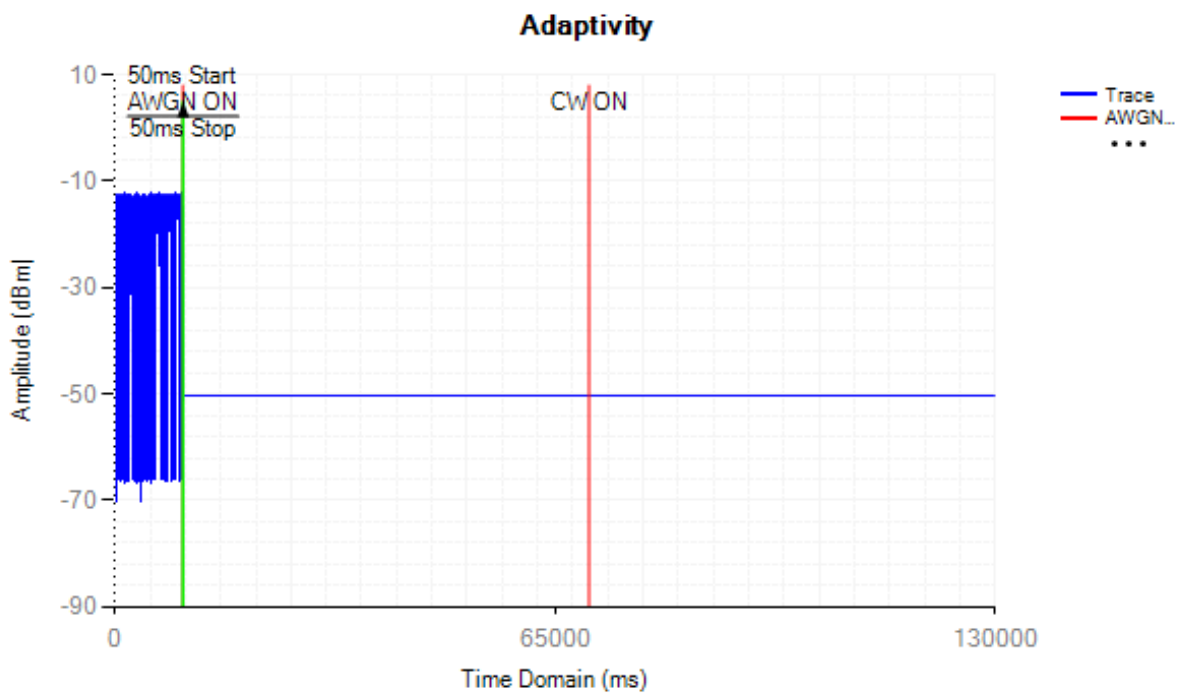

Control Signal NVNT g 2412MHz

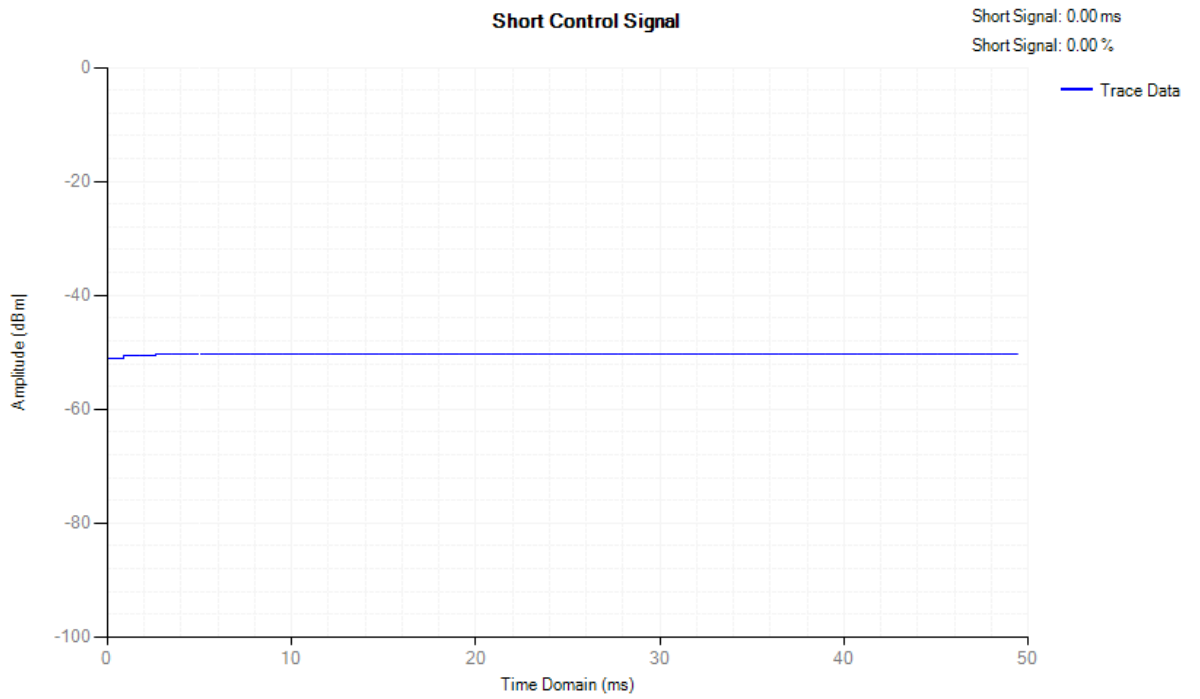

Adaptivity NVNT g 2472MHz

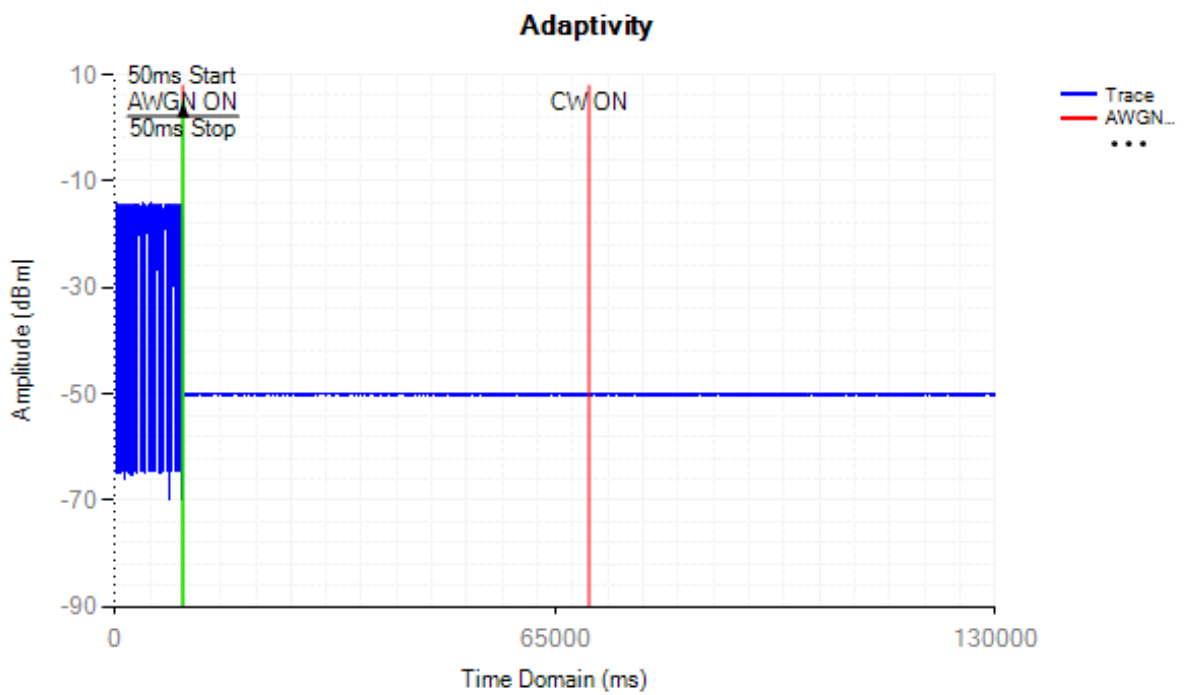

Control Signal NVNT g 2472MHz

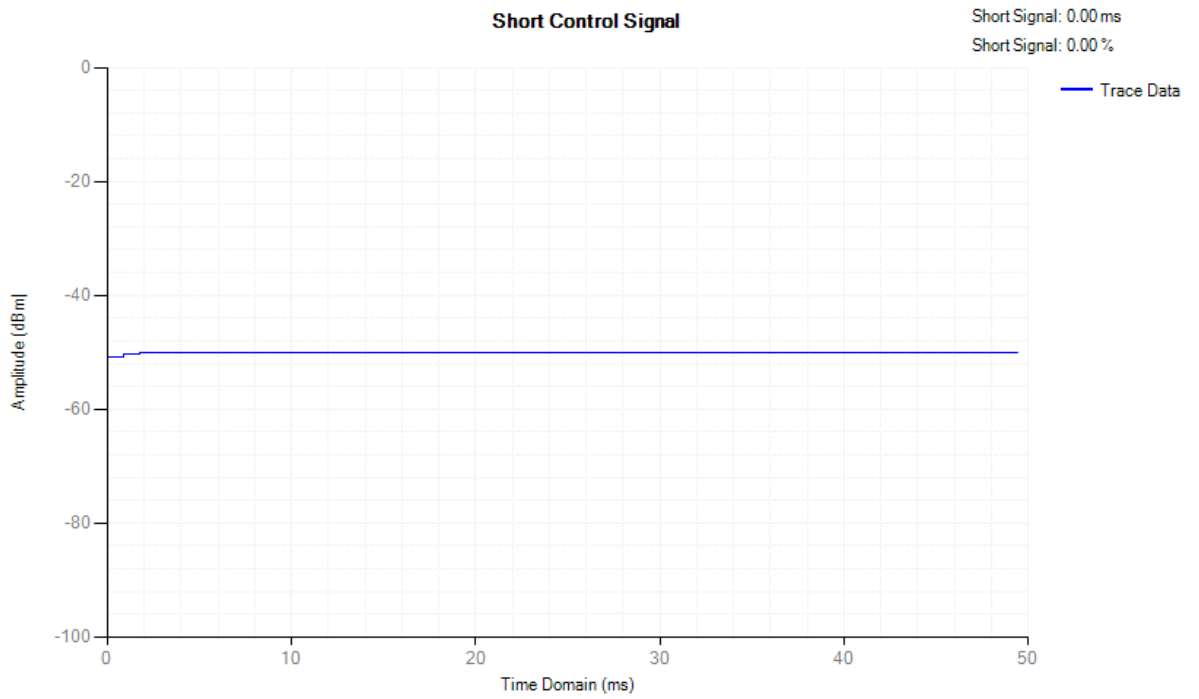

Adaptivity NVNT n20 2412MHz

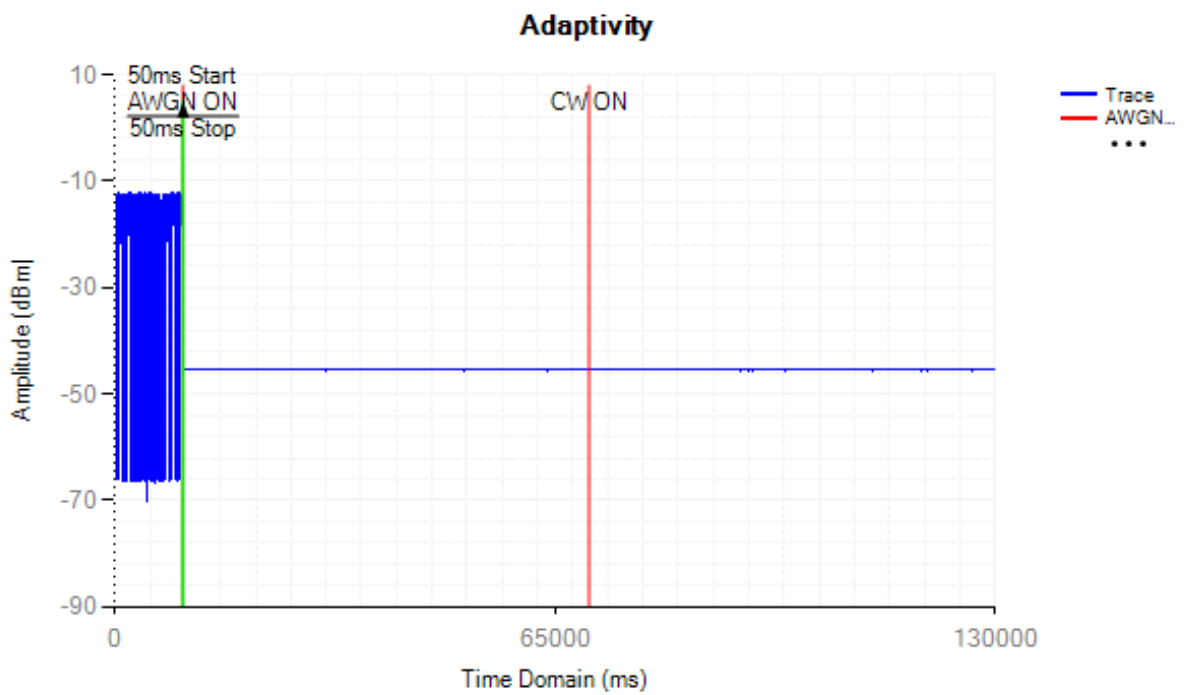

Control Signal NVNT n20 2412MHz

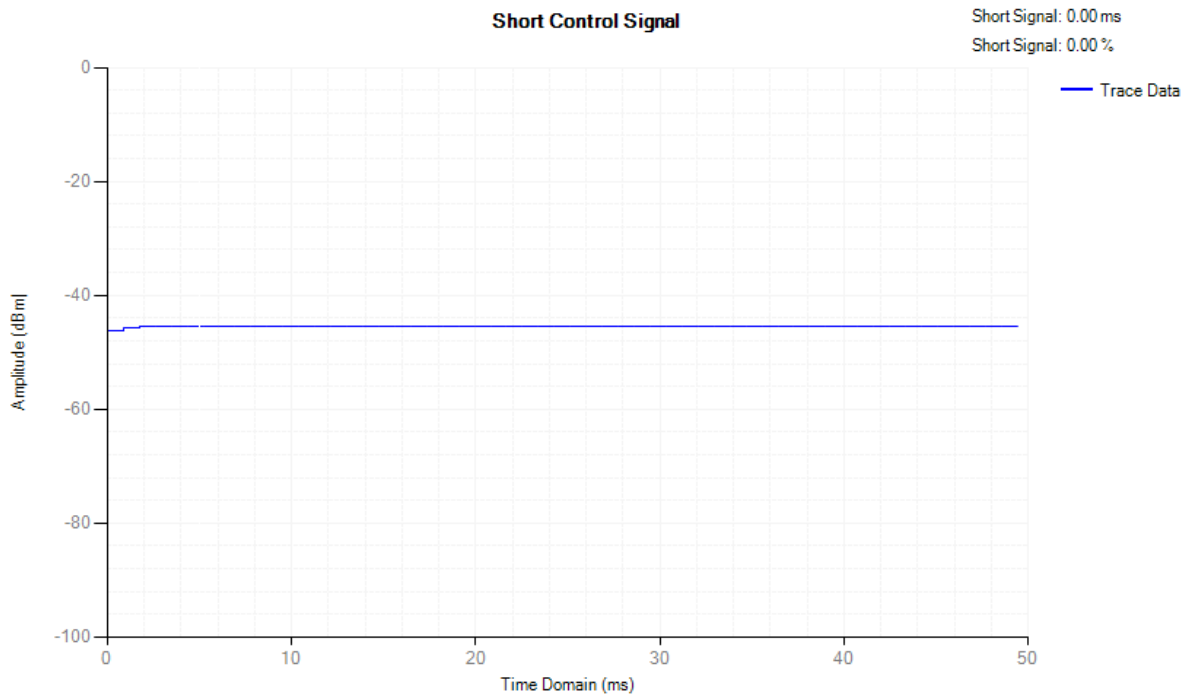

Adaptivity NVNT n20 2472MHz

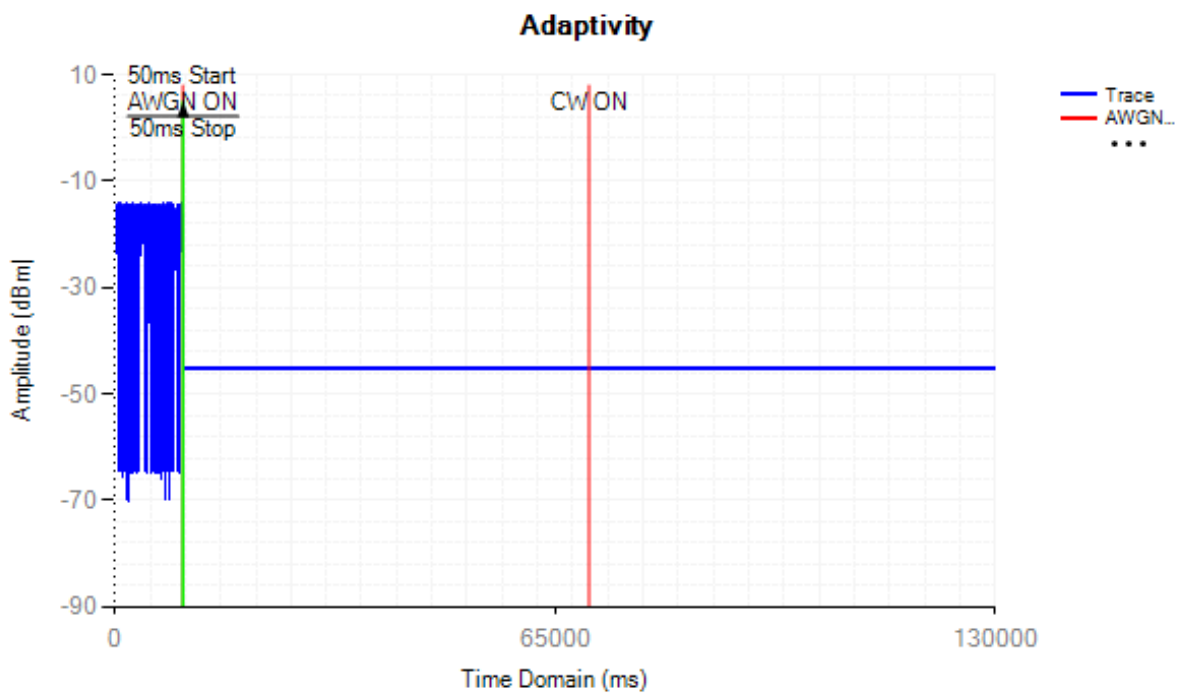

Control Signal NVNT n20 2472MHz

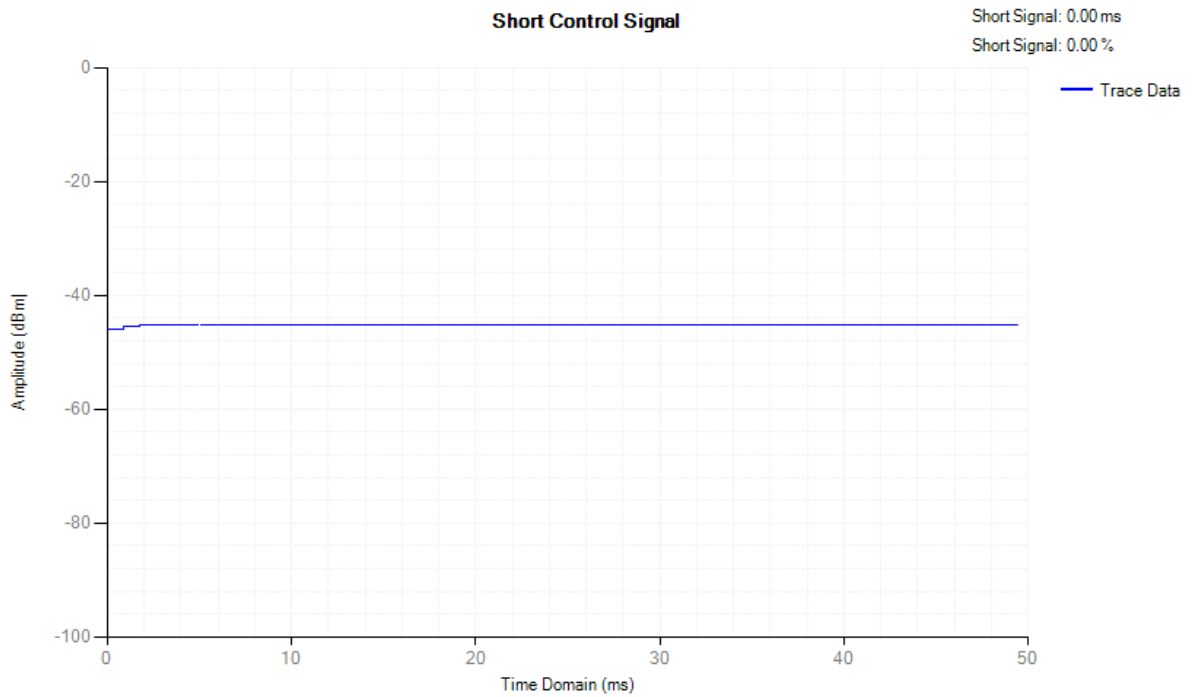
**Adaptivity COT**

Condition	Mode	Frequency (MHz)	Antenna	Max COT (ms)	Limit COT (ms)	Min Idle Time (ms)	Limit Idle Time (ms)	Verdict
NVNT	b	2412	Ant1	0.252	<=13	0.062	>0.018	Pass
NVNT	b	2472	Ant1	0.252	<=13	0.062	>0.018	Pass
NVNT	g	2412	Ant1	0.252	<=13	0.062	>0.018	Pass
NVNT	g	2472	Ant1	0.252	<=13	0.062	>0.018	Pass
NVNT	n20	2412	Ant1	0.252	<=13	0.062	>0.018	Pass
NVNT	n20	2472	Ant1	0.252	<=13	0.062	>0.018	Pass

COT NVNT b 2412MHz

Channel Occupation Time

Max COT: 0.25 ms

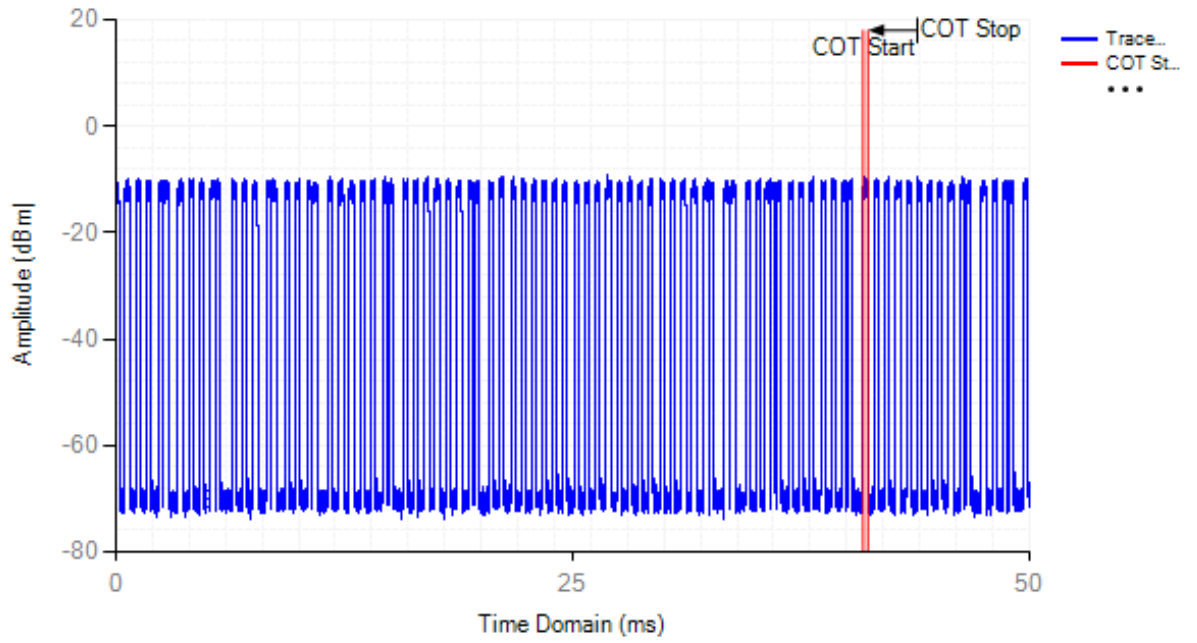

Idle NVNT b 2412MHz

Channel Occupation Time

Min Idle Time: 0.06 ms

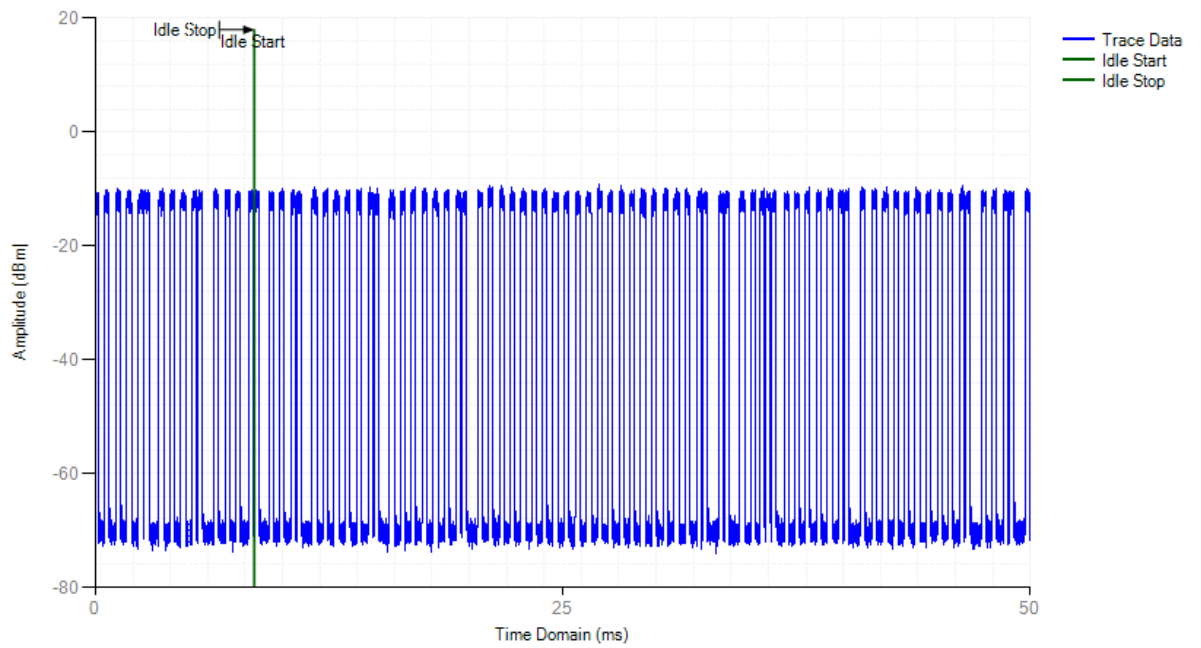

COT NVNT b 2472MHz

Channel Occupation Time

Max COT: 0.25 ms

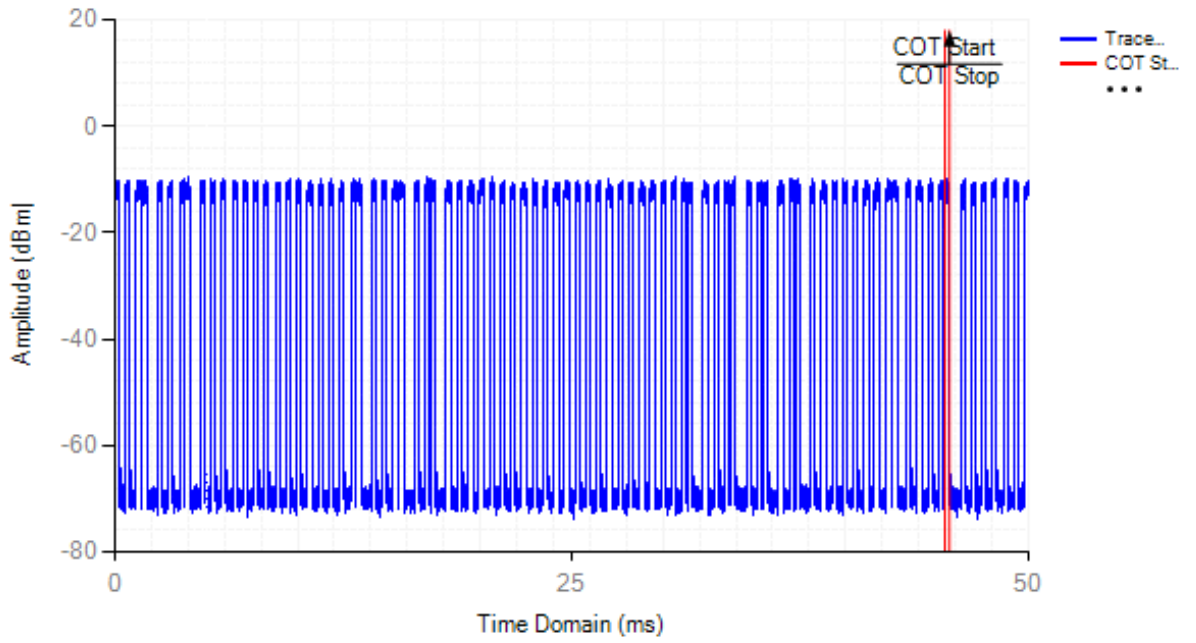

Idle NVNT b 2472MHz

Channel Occupation Time

Min Idle Time: 0.06 ms

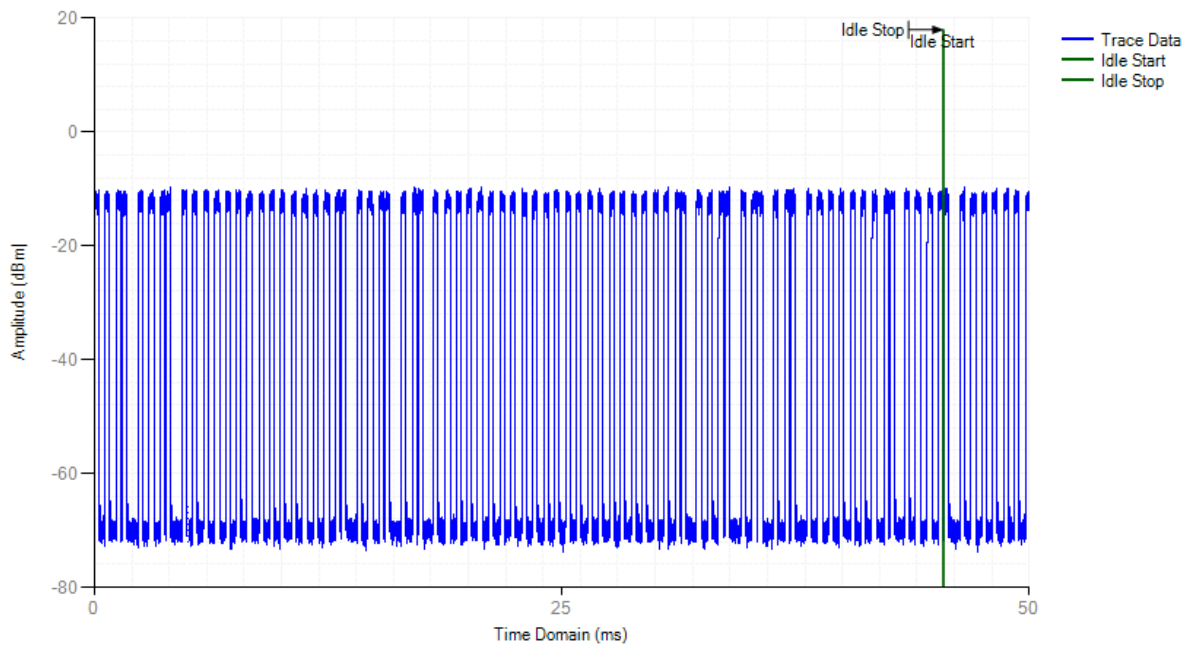

COT NVNT g 2412MHz



Idle NVNT g 2412MHz

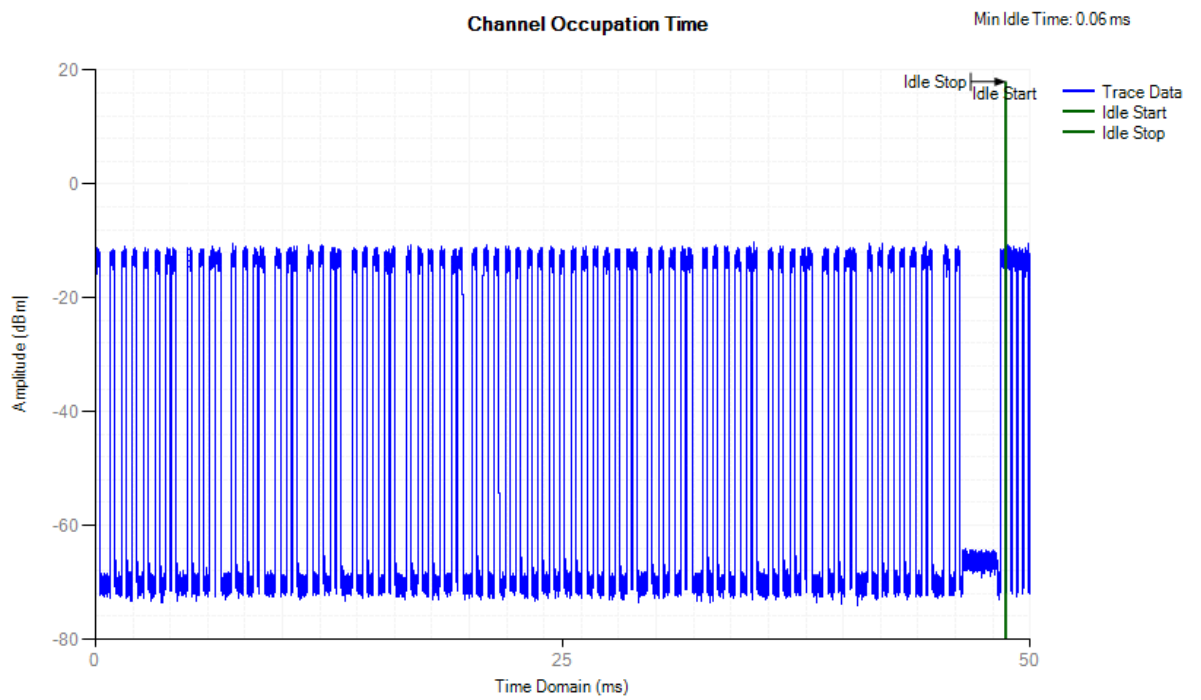

COT NVNT g 2472MHz

Channel Occupation Time

Max COT: 0.25 ms

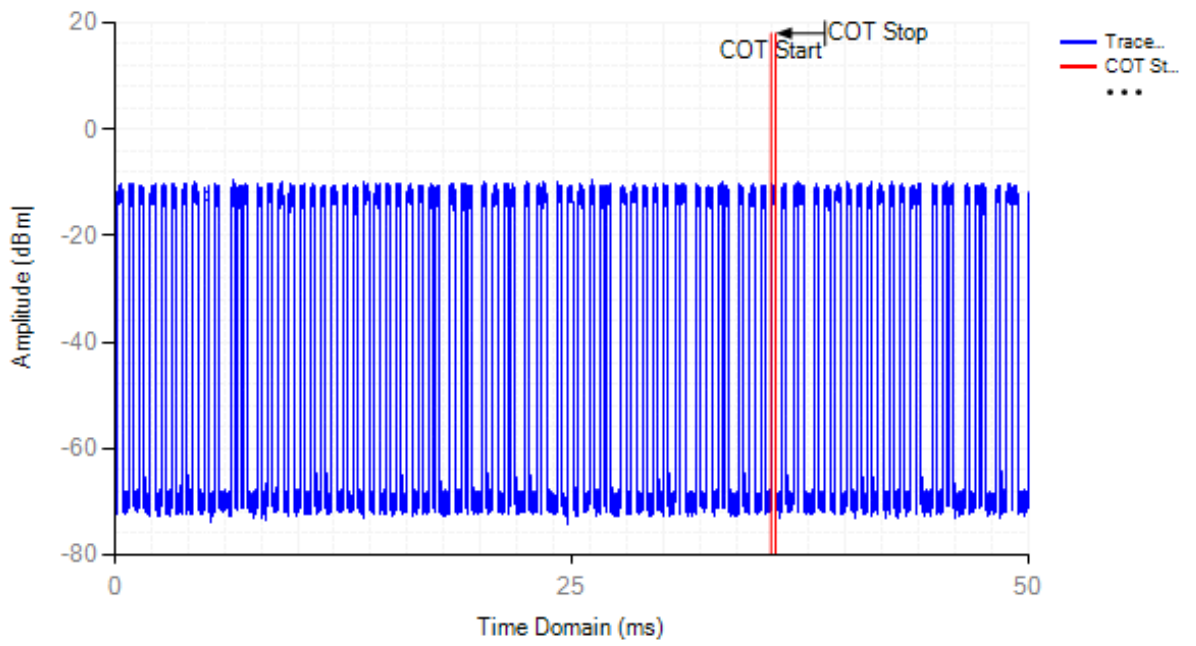

Idle NVNT g 2472MHz

Channel Occupation Time

Min Idle Time: 0.06 ms

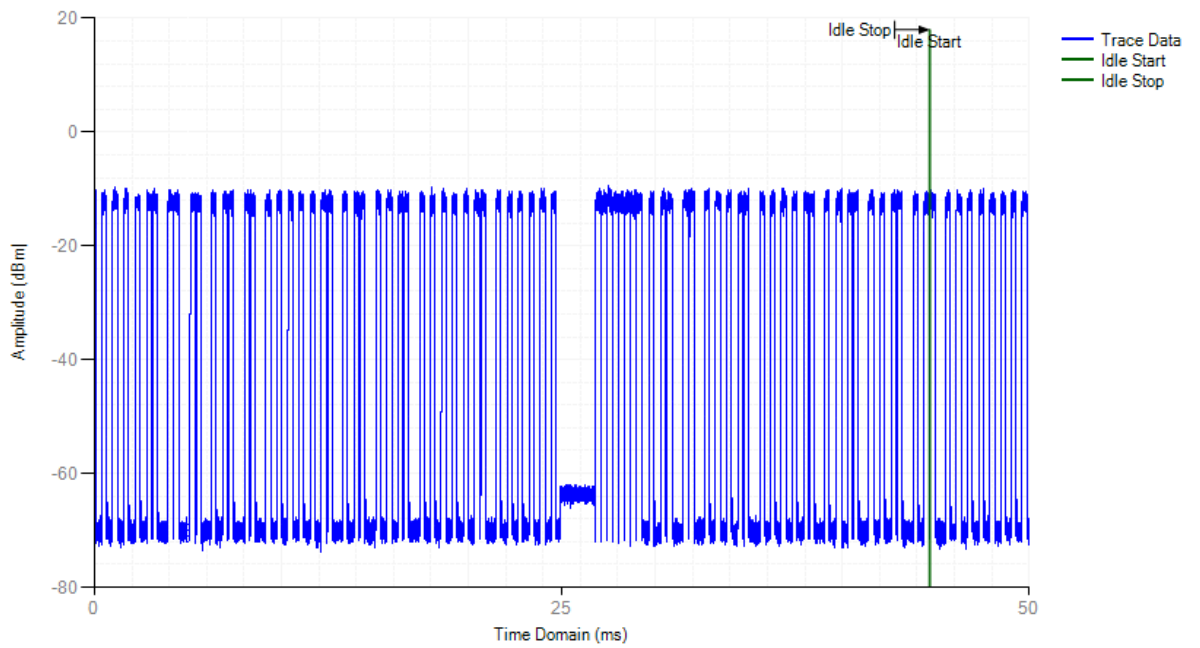

COT NVNT n20 2412MHz

Channel Occupation Time

Max COT: 0.25 ms

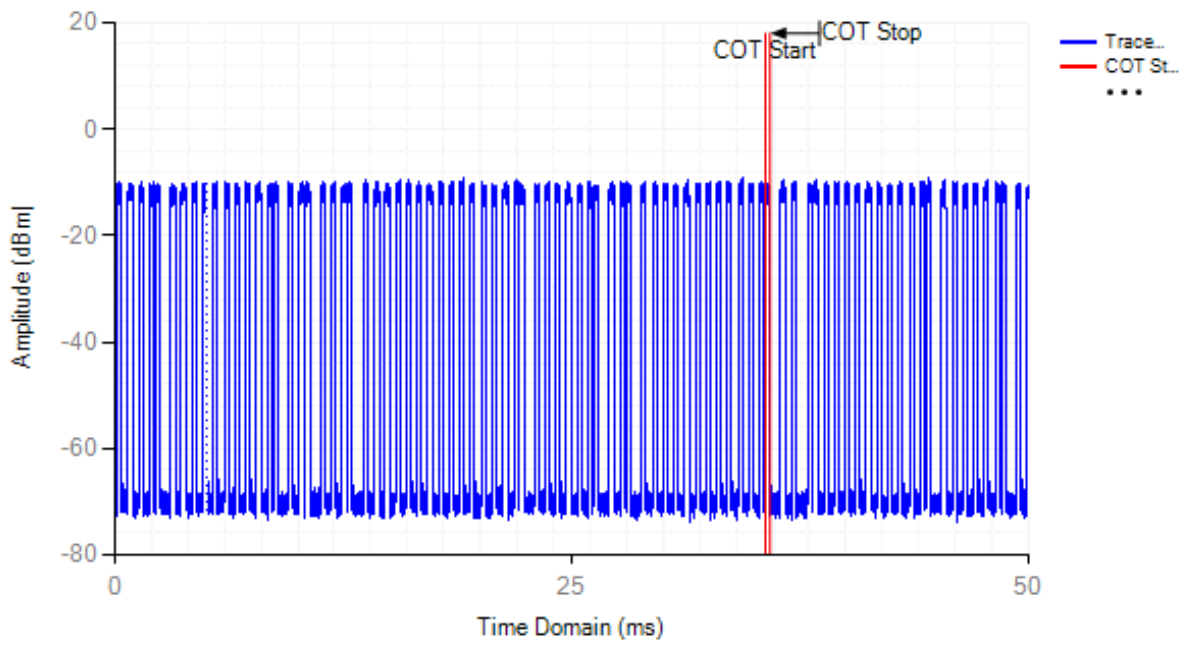

Idle NVNT n20 2412MHz

Channel Occupation Time

Min Idle Time: 0.06 ms

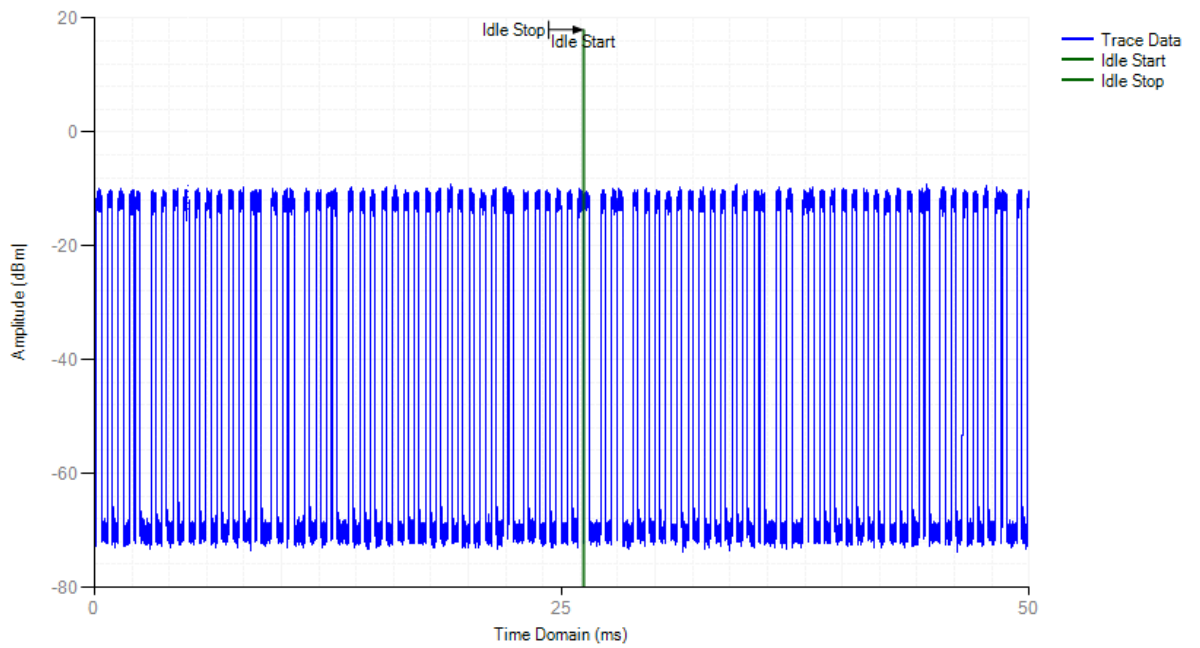

COT NVNT n20 2472MHz

Channel Occupation Time

Max COT: 0.25 ms

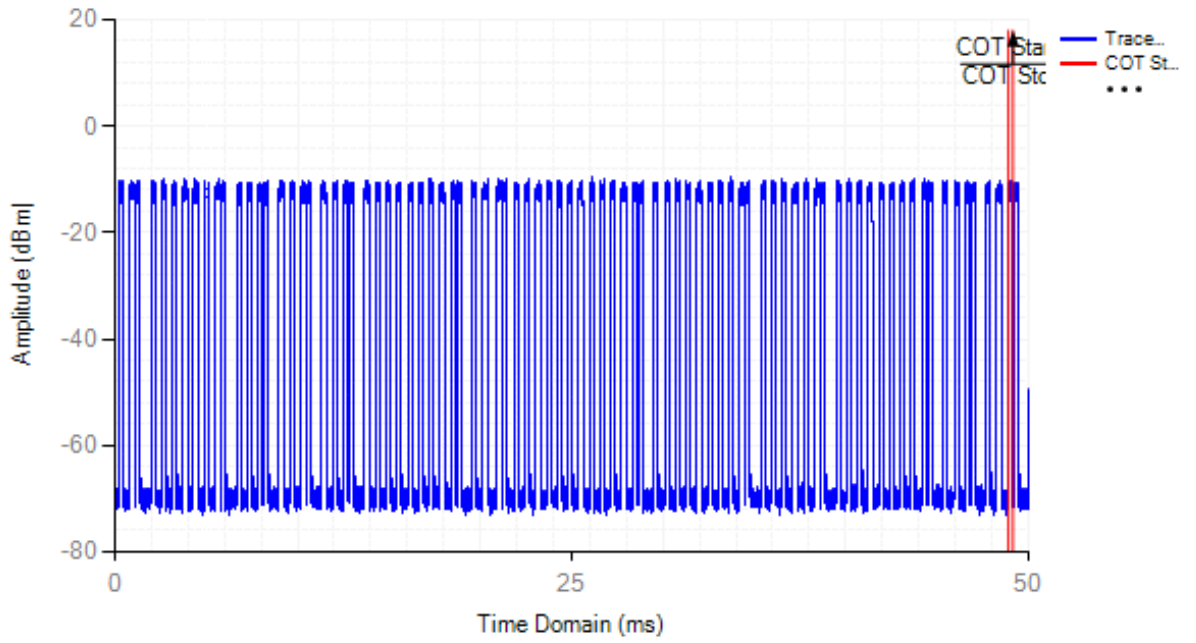

Idle NVNT n20 2472MHz

Channel Occupation Time

Min Idle Time: 0.06 ms

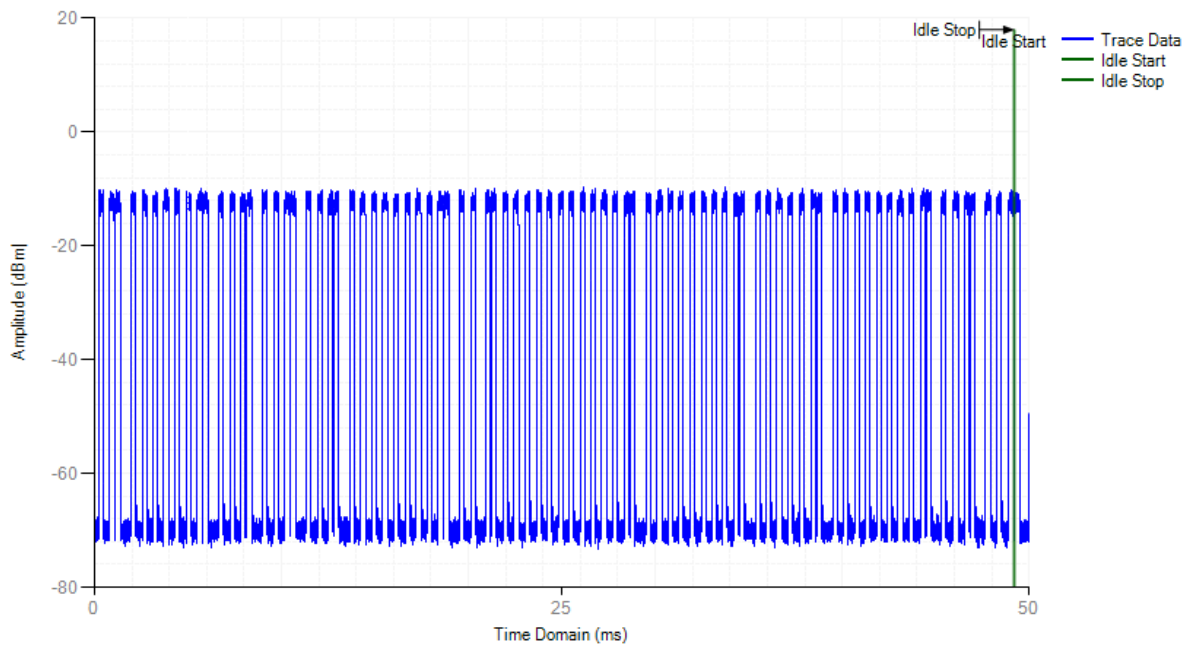

6. Occupied Channel Bandwidth

6.1. Limit

The Occupied Channel Bandwidth shall be within the band 2.4GHz to 2.4835GHz.

In addition, for non-adaptive non-FHSS equipment with e.i.r.p. greater than 10 dBm, the Occupied Channel Bandwidth shall be equal to or less than 20 MHz.

6.2. Test Setup

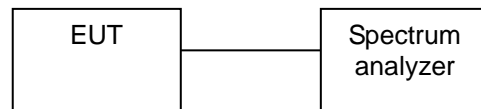

6.3. Test Procedure

Refer to ETSI EN 300 328 V2.2.2:2019 Clause 5.4.7.

Connect the UUT to the spectrum analyzer and use the following settings:

Centre Frequency	The centre frequency of the channel under test
Frequency Span	2 × Nominal Channel Bandwidth (e.g. 2 MHz for a 1 MHz channel)
RBW	~ 1 % of the span without going below 1 %
VBW	3 × RBW
Detector	RMS
Trace	Max hold
Sweep Time	1s

6.4. Test Result

Condition	Mode	Frequency (MHz)	Center Frequency (MHz)	OBW (MHz)	Lower Edge (MHz)	Upper Edge (MHz)	Limit OBW (MHz)	Verdict
NVNT	b	2412	2412.08	14.945	2404.607	2419.552	2400 - 2483.5MHz	Pass
NVNT	b	2442	2442.02	14.985	2434.527	2449.512	2400 - 2483.5MHz	Pass
NVNT	b	2472	2472.02	14.905	2464.567	2479.473	2400 - 2483.5MHz	Pass
NVNT	g	2412	2412.04	16.543	2403.768	2420.312	2400 - 2483.5MHz	Pass
NVNT	g	2442	2442.04	16.543	2433.768	2450.312	2400 - 2483.5MHz	Pass
NVNT	g	2472	2472.02	16.503	2463.768	2480.272	2400 - 2483.5MHz	Pass
NVNT	n20	2412	2412.02	17.702	2403.169	2420.871	2400 - 2483.5MHz	Pass
NVNT	n20	2442	2442.04	17.742	2433.169	2450.911	2400 - 2483.5MHz	Pass
NVNT	n20	2472	2472.04	17.742	2463.169	2480.911	2400 - 2483.5MHz	Pass
NVNT	n40	2422	2422.08	35.964	2404.098	2440.062	2400 - 2483.5MHz	Pass
NVNT	n40	2442	2442.12	36.523	2423.858	2460.382	2400 - 2483.5MHz	Pass
NVNT	n40	2462	2462.08	36.444	2443.858	2480.302	2400 - 2483.5MHz	Pass

OBW NVNT b 2412MHz Ant1

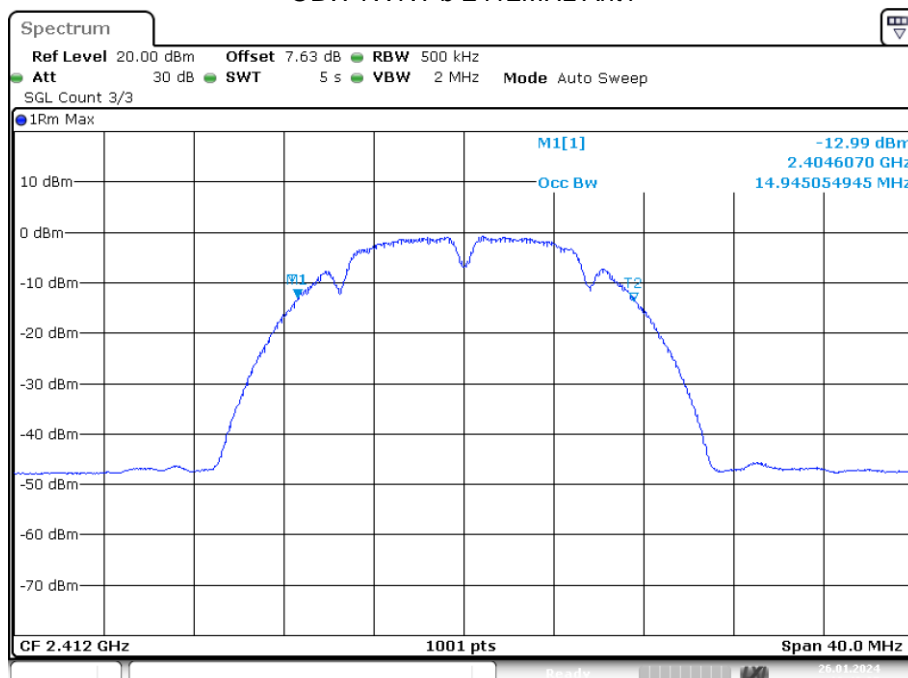

Date: 26.JAN.2024 13:49:07

OBW NVNT b 2442MHz Ant1

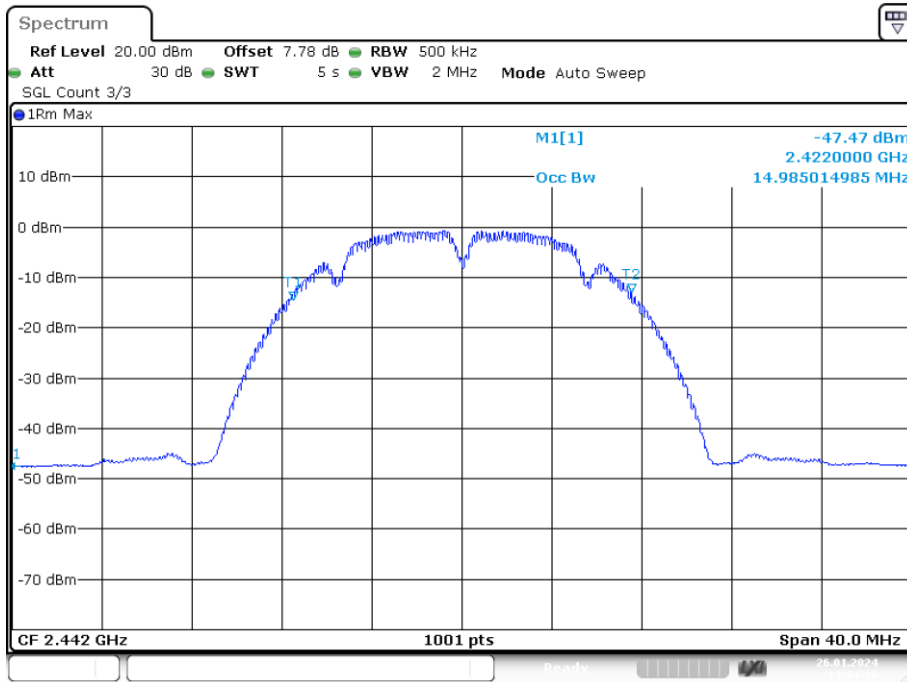

OBW NVNT b 2472MHz Ant1

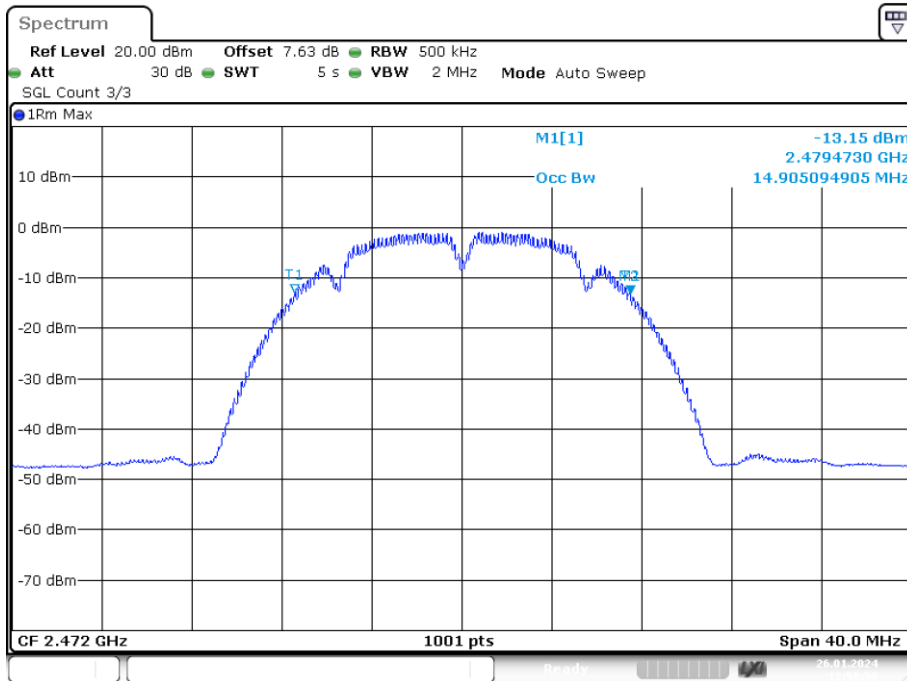

OBW NVNT g 2412MHz Ant1

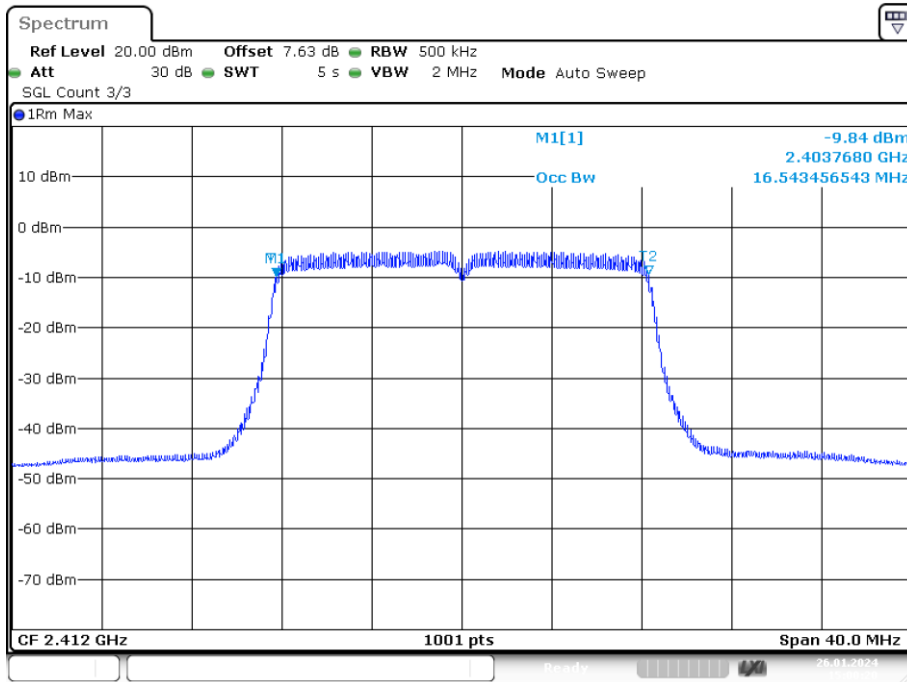

OBW NVNT g 2442MHz Ant1

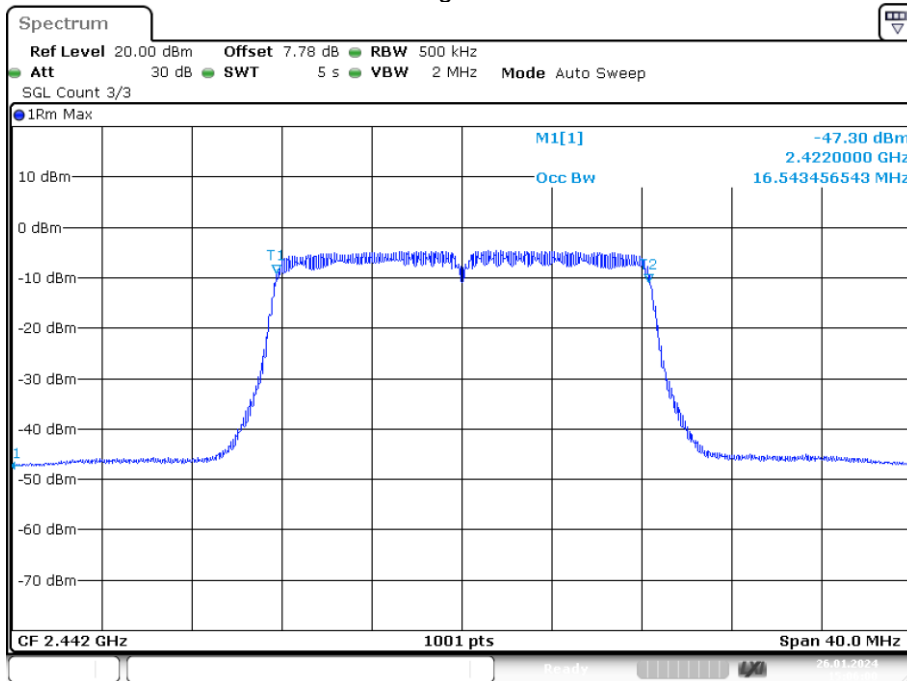

OBW NVNT g 2472MHz Ant1

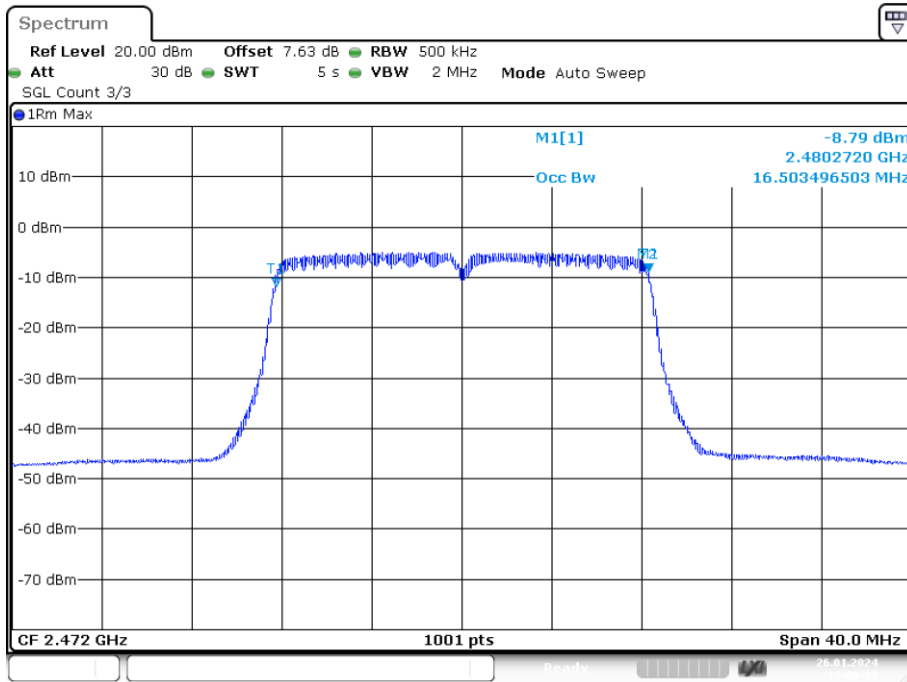

OBW NVNT n20 2412MHz Ant1

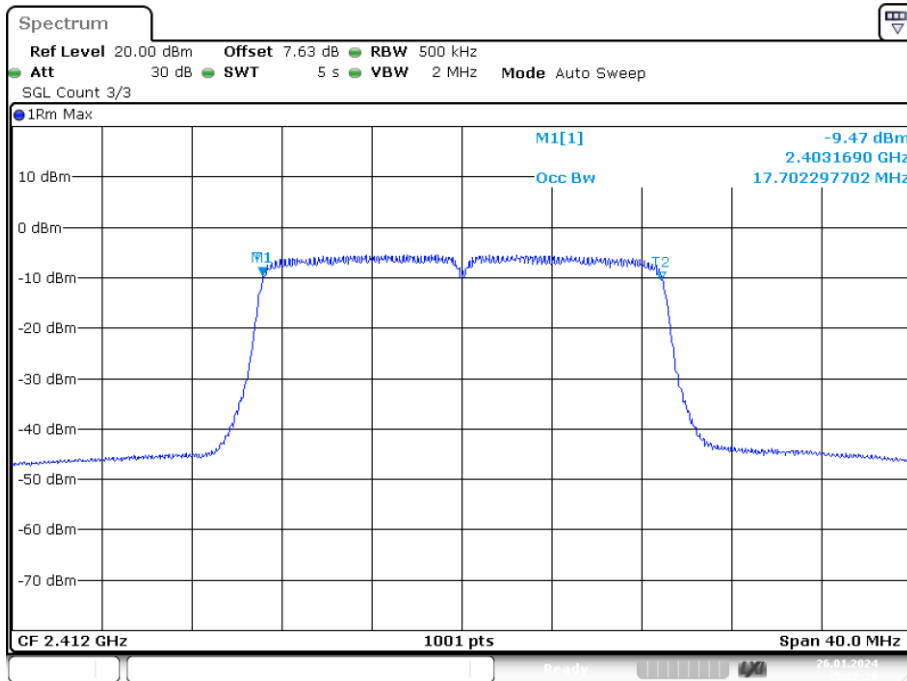

OBW NVNT n20 2442MHz Ant1

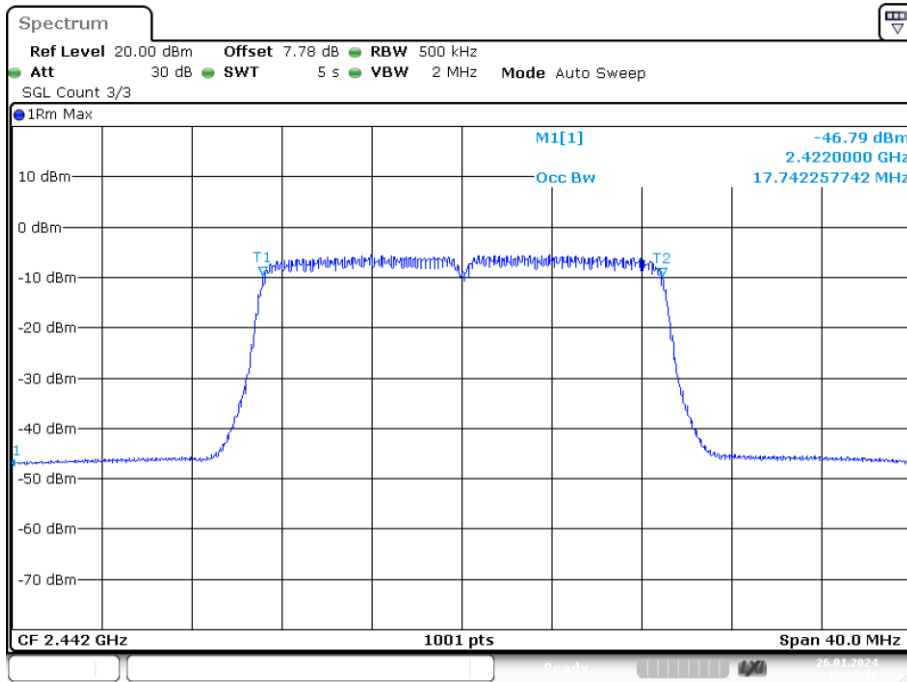

Date: 26.JAN.2024 15:35:10

OBW NVNT n20 2472MHz Ant1

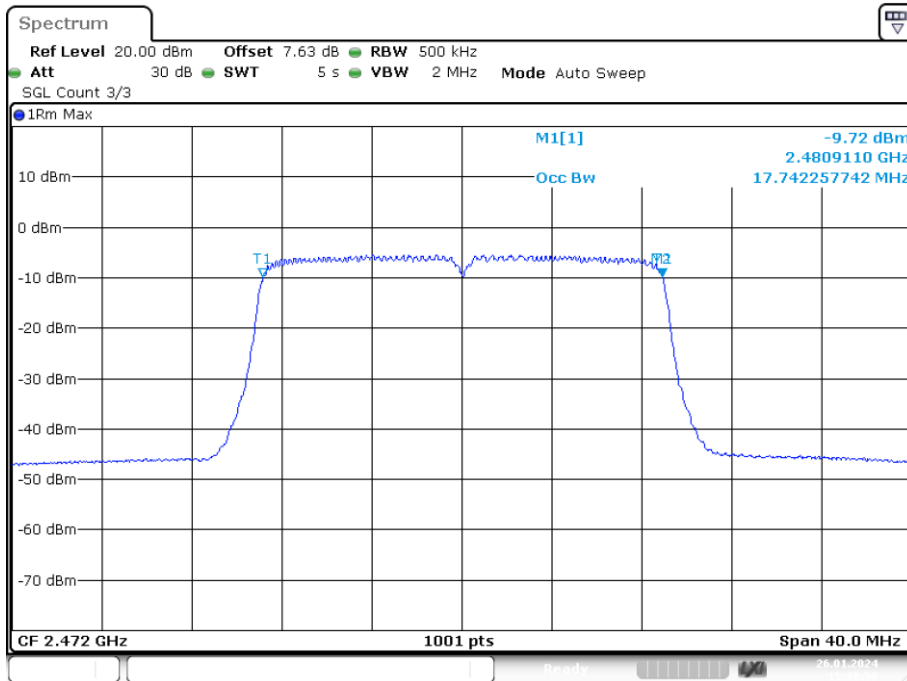

Date: 26.JAN.2024 15:38:51

OBW NVNT n40 2422MHz Ant1

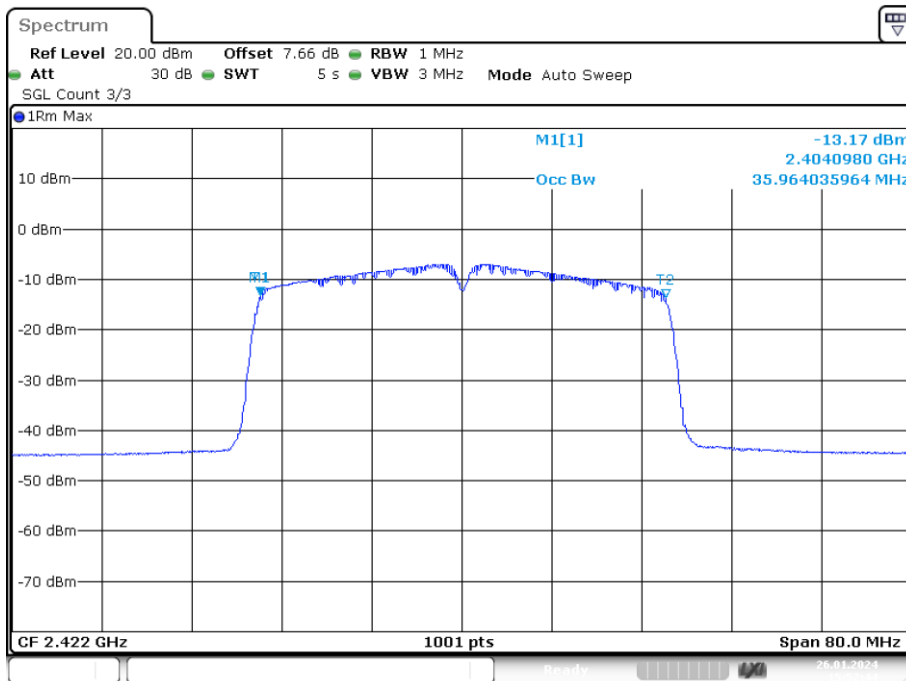

OBW NVNT n40 2442MHz Ant1

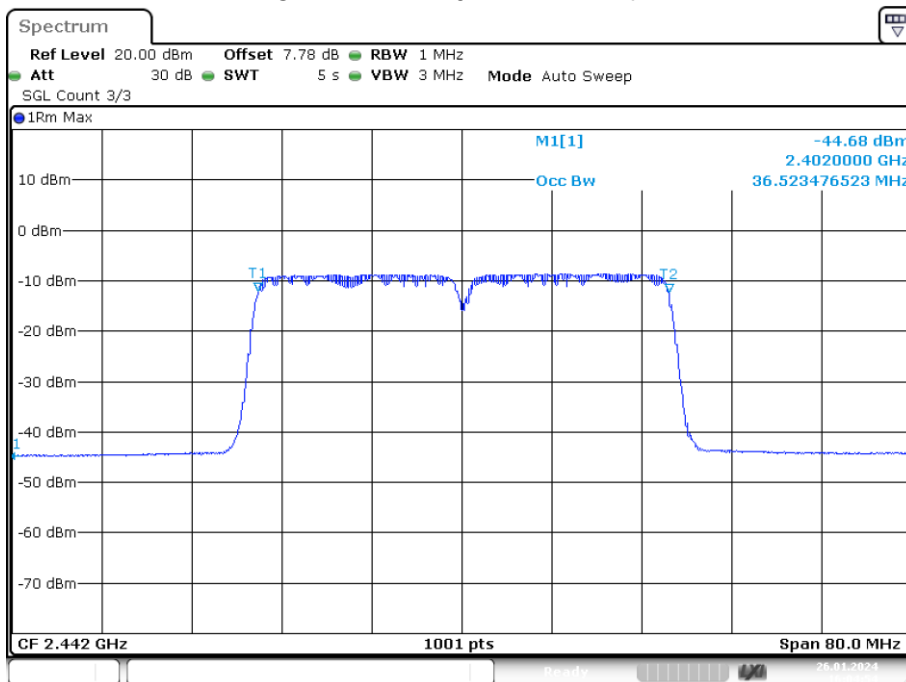

OBW NVNT n40 2462MHz Ant1

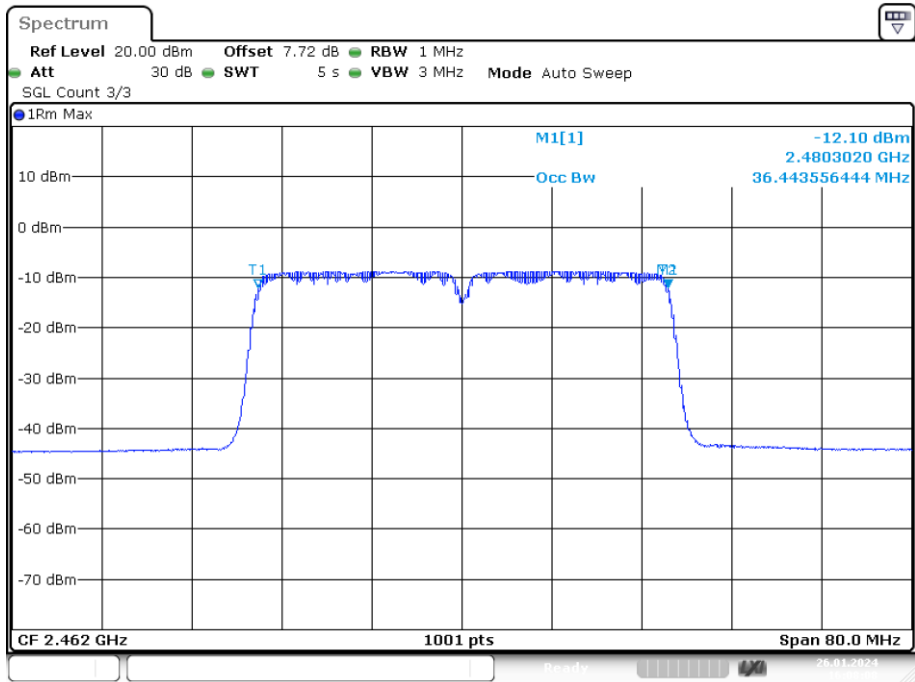

Date: 26.JAN.2024 16:08:08

7. Transmitter unwanted emissions in the out-of-band domain

7.1. Limit

The transmitter unwanted emissions in the out-of-band domain but outside the allocated band, shall not exceed the values provided by the mask in figure 3.

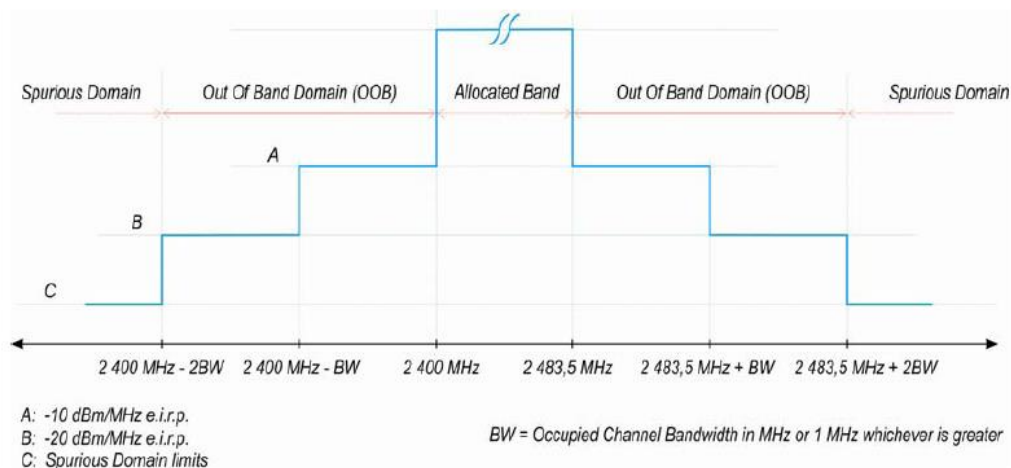
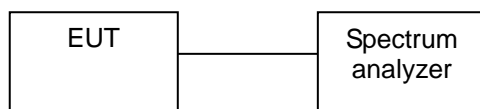

Figure 3: Transmit mask

7.2. Test Setup



7.3. Test Procedure

Refer to ETSI EN 300 328 V2.2.2:2019 Clause 5.4.8.

Connect the UUT to the spectrum analyzer and use the following settings:

RBW/ VBW	1MHz/3MHz
Span	0Hz
Filter mode	Channel filter
Sweep mode	Single Sweep
Sweep Points	Sweep time [μ s] / (1 μ s) with a maximum of 30 000
Sweep Time:	> 120 % of the duration of the longest burst detected during the measurement of the RF Output Power
Detector	RMS
Trace mode	Max Hold
Trigger Mode	Video trigger

7.4. Test Result

Condition	Mode	Frequency (MHz)	Antenna	OOB Frequency (MHz)	Level (dBm/MHz)	Limit (dBm/MHz)	Verdict
NVNT	b	2412	Ant1	2399.5	-44.07	-10	Pass
NVNT	b	2412	Ant1	2398.5	-45.15	-10	Pass
NVNT	b	2412	Ant1	2397.5	-44.15	-10	Pass
NVNT	b	2412	Ant1	2396.5	-48.21	-10	Pass
NVNT	b	2412	Ant1	2395.5	-49.6	-10	Pass
NVNT	b	2412	Ant1	2394.5	-49.68	-10	Pass
NVNT	b	2412	Ant1	2393.5	-49.8	-10	Pass
NVNT	b	2412	Ant1	2392.5	-50.49	-10	Pass
NVNT	b	2412	Ant1	2391.5	-50.94	-10	Pass
NVNT	b	2412	Ant1	2390.5	-50.58	-10	Pass
NVNT	b	2412	Ant1	2389.5	-51.28	-10	Pass
NVNT	b	2412	Ant1	2388.5	-51.8	-10	Pass
NVNT	b	2412	Ant1	2387.5	-50.73	-10	Pass
NVNT	b	2412	Ant1	2386.5	-51.66	-10	Pass
NVNT	b	2412	Ant1	2385.555	-52	-10	Pass
NVNT	b	2412	Ant1	2384.555	-52.29	-20	Pass
NVNT	b	2412	Ant1	2383.555	-52.45	-20	Pass
NVNT	b	2412	Ant1	2382.555	-52.58	-20	Pass
NVNT	b	2412	Ant1	2381.555	-52.25	-20	Pass
NVNT	b	2412	Ant1	2380.555	-52.25	-20	Pass
NVNT	b	2412	Ant1	2379.555	-52.46	-20	Pass
NVNT	b	2412	Ant1	2378.555	-52.8	-20	Pass
NVNT	b	2412	Ant1	2377.555	-52.81	-20	Pass
NVNT	b	2412	Ant1	2376.555	-53.25	-20	Pass
NVNT	b	2412	Ant1	2375.555	-53.06	-20	Pass
NVNT	b	2412	Ant1	2374.555	-52.93	-20	Pass
NVNT	b	2412	Ant1	2373.555	-52.92	-20	Pass
NVNT	b	2412	Ant1	2372.555	-53.21	-20	Pass
NVNT	b	2412	Ant1	2371.555	-53.46	-20	Pass
NVNT	b	2412	Ant1	2370.61	-53.28	-20	Pass
NVNT	b	2472	Ant1	2484	-45.46	-10	Pass
NVNT	b	2472	Ant1	2485	-40.77	-10	Pass
NVNT	b	2472	Ant1	2486	-43.05	-10	Pass
NVNT	b	2472	Ant1	2487	-43.63	-10	Pass
NVNT	b	2472	Ant1	2488	-43.5	-10	Pass
NVNT	b	2472	Ant1	2489	-47.34	-10	Pass
NVNT	b	2472	Ant1	2490	-46.37	-10	Pass
NVNT	b	2472	Ant1	2491	-48.65	-10	Pass
NVNT	b	2472	Ant1	2492	-48.97	-10	Pass
NVNT	b	2472	Ant1	2493	-49.66	-10	Pass
NVNT	b	2472	Ant1	2494	-50.53	-10	Pass
NVNT	b	2472	Ant1	2495	-50.86	-10	Pass
NVNT	b	2472	Ant1	2496	-50.46	-10	Pass
NVNT	b	2472	Ant1	2497	-50.36	-10	Pass
NVNT	b	2472	Ant1	2497.905	-50.42	-10	Pass
NVNT	b	2472	Ant1	2498.905	-51.55	-20	Pass
NVNT	b	2472	Ant1	2499.905	-51.59	-20	Pass
NVNT	b	2472	Ant1	2500.905	-51.76	-20	Pass
NVNT	b	2472	Ant1	2501.905	-52.15	-20	Pass
NVNT	b	2472	Ant1	2502.905	-51.22	-20	Pass
NVNT	b	2472	Ant1	2503.905	-51.55	-20	Pass
NVNT	b	2472	Ant1	2504.905	-52.32	-20	Pass
NVNT	b	2472	Ant1	2505.905	-52.36	-20	Pass

NVNT	b	2472	Ant1	2506.905	-52.05	-20	Pass
NVNT	b	2472	Ant1	2507.905	-51.84	-20	Pass
NVNT	b	2472	Ant1	2508.905	-51.97	-20	Pass
NVNT	b	2472	Ant1	2509.905	-51.31	-20	Pass
NVNT	b	2472	Ant1	2510.905	-52.46	-20	Pass
NVNT	b	2472	Ant1	2511.905	-52.33	-20	Pass
NVNT	b	2472	Ant1	2512.81	-52.58	-20	Pass
NVNT	g	2412	Ant1	2399.5	-34.64	-10	Pass
NVNT	g	2412	Ant1	2398.5	-34.59	-10	Pass
NVNT	g	2412	Ant1	2397.5	-35.08	-10	Pass
NVNT	g	2412	Ant1	2396.5	-34.95	-10	Pass
NVNT	g	2412	Ant1	2395.5	-33.84	-10	Pass
NVNT	g	2412	Ant1	2394.5	-34.79	-10	Pass
NVNT	g	2412	Ant1	2393.5	-38.62	-10	Pass
NVNT	g	2412	Ant1	2392.5	-39.42	-10	Pass
NVNT	g	2412	Ant1	2391.5	-40.19	-10	Pass
NVNT	g	2412	Ant1	2390.5	-43.28	-10	Pass
NVNT	g	2412	Ant1	2389.5	-43.9	-10	Pass
NVNT	g	2412	Ant1	2388.5	-47.65	-10	Pass
NVNT	g	2412	Ant1	2387.5	-48.56	-10	Pass
NVNT	g	2412	Ant1	2386.5	-48.58	-10	Pass
NVNT	g	2412	Ant1	2385.5	-49.54	-10	Pass
NVNT	g	2412	Ant1	2384.5	-49.33	-10	Pass
NVNT	g	2412	Ant1	2383.957	-49.61	-10	Pass
NVNT	g	2412	Ant1	2382.957	-50.2	-20	Pass
NVNT	g	2412	Ant1	2381.957	-50.28	-20	Pass
NVNT	g	2412	Ant1	2380.957	-50.51	-20	Pass
NVNT	g	2412	Ant1	2379.957	-50.08	-20	Pass
NVNT	g	2412	Ant1	2378.957	-50.59	-20	Pass
NVNT	g	2412	Ant1	2377.957	-51.1	-20	Pass
NVNT	g	2412	Ant1	2376.957	-51.07	-20	Pass
NVNT	g	2412	Ant1	2375.957	-50.86	-20	Pass
NVNT	g	2412	Ant1	2374.957	-51.08	-20	Pass
NVNT	g	2412	Ant1	2373.957	-51.43	-20	Pass
NVNT	g	2412	Ant1	2372.957	-51.66	-20	Pass
NVNT	g	2412	Ant1	2371.957	-51.68	-20	Pass
NVNT	g	2412	Ant1	2370.957	-51.37	-20	Pass
NVNT	g	2412	Ant1	2369.957	-51.3	-20	Pass
NVNT	g	2412	Ant1	2368.957	-51.38	-20	Pass
NVNT	g	2412	Ant1	2367.957	-51.55	-20	Pass
NVNT	g	2412	Ant1	2367.414	-51.77	-20	Pass
NVNT	g	2472	Ant1	2484	-33.79	-10	Pass
NVNT	g	2472	Ant1	2485	-33.29	-10	Pass
NVNT	g	2472	Ant1	2486	-34.65	-10	Pass
NVNT	g	2472	Ant1	2487	-34.78	-10	Pass
NVNT	g	2472	Ant1	2488	-34.94	-10	Pass
NVNT	g	2472	Ant1	2489	-35.76	-10	Pass
NVNT	g	2472	Ant1	2490	-37.4	-10	Pass
NVNT	g	2472	Ant1	2491	-39.43	-10	Pass
NVNT	g	2472	Ant1	2492	-41.1	-10	Pass
NVNT	g	2472	Ant1	2493	-40.03	-10	Pass
NVNT	g	2472	Ant1	2494	-43.79	-10	Pass
NVNT	g	2472	Ant1	2495	-45.85	-10	Pass
NVNT	g	2472	Ant1	2496	-48	-10	Pass
NVNT	g	2472	Ant1	2497	-48.98	-10	Pass
NVNT	g	2472	Ant1	2498	-49.26	-10	Pass
NVNT	g	2472	Ant1	2499	-49.34	-10	Pass
NVNT	g	2472	Ant1	2499.503	-49.46	-10	Pass
NVNT	g	2472	Ant1	2500.503	-49.67	-20	Pass

NVNT	g	2472	Ant1	2501.503	-49.72	-20	Pass
NVNT	g	2472	Ant1	2502.503	-49.68	-20	Pass
NVNT	g	2472	Ant1	2503.503	-49.82	-20	Pass
NVNT	g	2472	Ant1	2504.503	-49.99	-20	Pass
NVNT	g	2472	Ant1	2505.503	-50.19	-20	Pass
NVNT	g	2472	Ant1	2506.503	-50.04	-20	Pass
NVNT	g	2472	Ant1	2507.503	-49.78	-20	Pass
NVNT	g	2472	Ant1	2508.503	-49.79	-20	Pass
NVNT	g	2472	Ant1	2509.503	-49.97	-20	Pass
NVNT	g	2472	Ant1	2510.503	-50.07	-20	Pass
NVNT	g	2472	Ant1	2511.503	-50.92	-20	Pass
NVNT	g	2472	Ant1	2512.503	-50.95	-20	Pass
NVNT	g	2472	Ant1	2513.503	-51.05	-20	Pass
NVNT	g	2472	Ant1	2514.503	-51.04	-20	Pass
NVNT	g	2472	Ant1	2515.503	-51.15	-20	Pass
NVNT	g	2472	Ant1	2516.006	-51.27	-20	Pass
NVNT	n20	2412	Ant1	2399.5	-33.57	-10	Pass
NVNT	n20	2412	Ant1	2398.5	-34.17	-10	Pass
NVNT	n20	2412	Ant1	2397.5	-34.43	-10	Pass
NVNT	n20	2412	Ant1	2396.5	-35.29	-10	Pass
NVNT	n20	2412	Ant1	2395.5	-35.3	-10	Pass
NVNT	n20	2412	Ant1	2394.5	-36.15	-10	Pass
NVNT	n20	2412	Ant1	2393.5	-36.79	-10	Pass
NVNT	n20	2412	Ant1	2392.5	-37.7	-10	Pass
NVNT	n20	2412	Ant1	2391.5	-38.75	-10	Pass
NVNT	n20	2412	Ant1	2390.5	-39.78	-10	Pass
NVNT	n20	2412	Ant1	2389.5	-41.75	-10	Pass
NVNT	n20	2412	Ant1	2388.5	-43.84	-10	Pass
NVNT	n20	2412	Ant1	2387.5	-46.85	-10	Pass
NVNT	n20	2412	Ant1	2386.5	-48.79	-10	Pass
NVNT	n20	2412	Ant1	2385.5	-49.79	-10	Pass
NVNT	n20	2412	Ant1	2384.5	-49.84	-10	Pass
NVNT	n20	2412	Ant1	2383.5	-50.11	-10	Pass
NVNT	n20	2412	Ant1	2382.798	-50.21	-10	Pass
NVNT	n20	2412	Ant1	2381.798	-50.45	-20	Pass
NVNT	n20	2412	Ant1	2380.798	-50.13	-20	Pass
NVNT	n20	2412	Ant1	2379.798	-49.98	-20	Pass
NVNT	n20	2412	Ant1	2378.798	-50.63	-20	Pass
NVNT	n20	2412	Ant1	2377.798	-51.04	-20	Pass
NVNT	n20	2412	Ant1	2376.798	-50.96	-20	Pass
NVNT	n20	2412	Ant1	2375.798	-51.01	-20	Pass
NVNT	n20	2412	Ant1	2374.798	-51.06	-20	Pass
NVNT	n20	2412	Ant1	2373.798	-51.41	-20	Pass
NVNT	n20	2412	Ant1	2372.798	-51.61	-20	Pass
NVNT	n20	2412	Ant1	2371.798	-51.54	-20	Pass
NVNT	n20	2412	Ant1	2370.798	-51.2	-20	Pass
NVNT	n20	2412	Ant1	2369.798	-51.24	-20	Pass
NVNT	n20	2412	Ant1	2368.798	-51.32	-20	Pass
NVNT	n20	2412	Ant1	2367.798	-51.51	-20	Pass
NVNT	n20	2412	Ant1	2366.798	-51.94	-20	Pass
NVNT	n20	2412	Ant1	2365.798	-52.13	-20	Pass
NVNT	n20	2412	Ant1	2365.096	-52.3	-20	Pass
NVNT	n20	2472	Ant1	2484	-33.26	-10	Pass
NVNT	n20	2472	Ant1	2485	-34.33	-10	Pass
NVNT	n20	2472	Ant1	2486	-34.35	-10	Pass
NVNT	n20	2472	Ant1	2487	-34.39	-10	Pass
NVNT	n20	2472	Ant1	2488	-34.71	-10	Pass
NVNT	n20	2472	Ant1	2489	-35.28	-10	Pass
NVNT	n20	2472	Ant1	2490	-35.79	-10	Pass

NVNT	n20	2472	Ant1	2491	-36.66	-10	Pass
NVNT	n20	2472	Ant1	2492	-37.83	-10	Pass
NVNT	n20	2472	Ant1	2493	-37.91	-10	Pass
NVNT	n20	2472	Ant1	2494	-39.32	-10	Pass
NVNT	n20	2472	Ant1	2495	-42.01	-10	Pass
NVNT	n20	2472	Ant1	2496	-44.37	-10	Pass
NVNT	n20	2472	Ant1	2497	-46.74	-10	Pass
NVNT	n20	2472	Ant1	2498	-48.39	-10	Pass
NVNT	n20	2472	Ant1	2499	-48.53	-10	Pass
NVNT	n20	2472	Ant1	2500	-49.13	-10	Pass
NVNT	n20	2472	Ant1	2500.742	-49.45	-10	Pass
NVNT	n20	2472	Ant1	2501.742	-49.63	-20	Pass
NVNT	n20	2472	Ant1	2502.742	-49.63	-20	Pass
NVNT	n20	2472	Ant1	2503.742	-49.34	-20	Pass
NVNT	n20	2472	Ant1	2504.742	-49.7	-20	Pass
NVNT	n20	2472	Ant1	2505.742	-50.08	-20	Pass
NVNT	n20	2472	Ant1	2506.742	-49.92	-20	Pass
NVNT	n20	2472	Ant1	2507.742	-49.58	-20	Pass
NVNT	n20	2472	Ant1	2508.742	-49.59	-20	Pass
NVNT	n20	2472	Ant1	2509.742	-49.56	-20	Pass
NVNT	n20	2472	Ant1	2510.742	-50.47	-20	Pass
NVNT	n20	2472	Ant1	2511.742	-50.8	-20	Pass
NVNT	n20	2472	Ant1	2512.742	-51.05	-20	Pass
NVNT	n20	2472	Ant1	2513.742	-50.91	-20	Pass
NVNT	n20	2472	Ant1	2514.742	-50.99	-20	Pass
NVNT	n20	2472	Ant1	2515.742	-51.19	-20	Pass
NVNT	n20	2472	Ant1	2516.742	-51.31	-20	Pass
NVNT	n20	2472	Ant1	2517.742	-51.38	-20	Pass
NVNT	n20	2472	Ant1	2518.484	-51.37	-20	Pass
NVNT	n40	2422	Ant1	2399.5	-36.75	-10	Pass
NVNT	n40	2422	Ant1	2398.5	-37.26	-10	Pass
NVNT	n40	2422	Ant1	2397.5	-36.49	-10	Pass
NVNT	n40	2422	Ant1	2396.5	-37.24	-10	Pass
NVNT	n40	2422	Ant1	2395.5	-38.69	-10	Pass
NVNT	n40	2422	Ant1	2394.5	-38.78	-10	Pass
NVNT	n40	2422	Ant1	2393.5	-40.14	-10	Pass
NVNT	n40	2422	Ant1	2392.5	-40.54	-10	Pass
NVNT	n40	2422	Ant1	2391.5	-41.76	-10	Pass
NVNT	n40	2422	Ant1	2390.5	-42.31	-10	Pass
NVNT	n40	2422	Ant1	2389.5	-43.11	-10	Pass
NVNT	n40	2422	Ant1	2388.5	-43.54	-10	Pass
NVNT	n40	2422	Ant1	2387.5	-44.55	-10	Pass
NVNT	n40	2422	Ant1	2386.5	-45.02	-10	Pass
NVNT	n40	2422	Ant1	2385.5	-45.16	-10	Pass
NVNT	n40	2422	Ant1	2384.5	-45.55	-10	Pass
NVNT	n40	2422	Ant1	2383.5	-45.89	-10	Pass
NVNT	n40	2422	Ant1	2382.5	-45.74	-10	Pass
NVNT	n40	2422	Ant1	2381.5	-46.15	-10	Pass
NVNT	n40	2422	Ant1	2380.5	-46.47	-10	Pass
NVNT	n40	2422	Ant1	2379.5	-46.64	-10	Pass
NVNT	n40	2422	Ant1	2378.5	-46.76	-10	Pass
NVNT	n40	2422	Ant1	2377.5	-47.5	-10	Pass
NVNT	n40	2422	Ant1	2376.5	-47.4	-10	Pass
NVNT	n40	2422	Ant1	2375.5	-47.99	-10	Pass
NVNT	n40	2422	Ant1	2374.5	-48.39	-10	Pass
NVNT	n40	2422	Ant1	2373.5	-48.18	-10	Pass
NVNT	n40	2422	Ant1	2372.5	-49.24	-10	Pass
NVNT	n40	2422	Ant1	2371.5	-49.59	-10	Pass
NVNT	n40	2422	Ant1	2370.5	-49.72	-10	Pass

NVNT	n40	2422	Ant1	2369.5	-50.16	-10	Pass
NVNT	n40	2422	Ant1	2368.5	-50.39	-10	Pass
NVNT	n40	2422	Ant1	2367.5	-50.71	-10	Pass
NVNT	n40	2422	Ant1	2366.5	-50.82	-10	Pass
NVNT	n40	2422	Ant1	2365.5	-50.92	-10	Pass
NVNT	n40	2422	Ant1	2364.536	-50.76	-10	Pass
NVNT	n40	2422	Ant1	2363.536	-50.98	-20	Pass
NVNT	n40	2422	Ant1	2362.536	-50.96	-20	Pass
NVNT	n40	2422	Ant1	2361.536	-51.19	-20	Pass
NVNT	n40	2422	Ant1	2360.536	-51.15	-20	Pass
NVNT	n40	2422	Ant1	2359.536	-50.9	-20	Pass
NVNT	n40	2422	Ant1	2358.536	-50.89	-20	Pass
NVNT	n40	2422	Ant1	2357.536	-51.09	-20	Pass
NVNT	n40	2422	Ant1	2356.536	-51.31	-20	Pass
NVNT	n40	2422	Ant1	2355.536	-51.51	-20	Pass
NVNT	n40	2422	Ant1	2354.536	-51.74	-20	Pass
NVNT	n40	2422	Ant1	2353.536	-51.74	-20	Pass
NVNT	n40	2422	Ant1	2352.536	-51.67	-20	Pass
NVNT	n40	2422	Ant1	2351.536	-51.75	-20	Pass
NVNT	n40	2422	Ant1	2350.536	-51.98	-20	Pass
NVNT	n40	2422	Ant1	2349.536	-51.9	-20	Pass
NVNT	n40	2422	Ant1	2348.536	-51.98	-20	Pass
NVNT	n40	2422	Ant1	2347.536	-52.04	-20	Pass
NVNT	n40	2422	Ant1	2346.536	-52.15	-20	Pass
NVNT	n40	2422	Ant1	2345.536	-52.22	-20	Pass
NVNT	n40	2422	Ant1	2344.536	-52.26	-20	Pass
NVNT	n40	2422	Ant1	2343.536	-52.25	-20	Pass
NVNT	n40	2422	Ant1	2342.536	-52.4	-20	Pass
NVNT	n40	2422	Ant1	2341.536	-52.28	-20	Pass
NVNT	n40	2422	Ant1	2340.536	-52.3	-20	Pass
NVNT	n40	2422	Ant1	2339.536	-52.4	-20	Pass
NVNT	n40	2422	Ant1	2338.536	-52.43	-20	Pass
NVNT	n40	2422	Ant1	2337.536	-52.47	-20	Pass
NVNT	n40	2422	Ant1	2336.536	-52.68	-20	Pass
NVNT	n40	2422	Ant1	2335.536	-52.66	-20	Pass
NVNT	n40	2422	Ant1	2334.536	-52.72	-20	Pass
NVNT	n40	2422	Ant1	2333.536	-52.65	-20	Pass
NVNT	n40	2422	Ant1	2332.536	-52.93	-20	Pass
NVNT	n40	2422	Ant1	2331.536	-52.97	-20	Pass
NVNT	n40	2422	Ant1	2330.536	-53.04	-20	Pass
NVNT	n40	2422	Ant1	2329.536	-53.1	-20	Pass
NVNT	n40	2422	Ant1	2328.572	-53.08	-20	Pass
NVNT	n40	2462	Ant1	2484	-34.8	-10	Pass
NVNT	n40	2462	Ant1	2485	-35.24	-10	Pass
NVNT	n40	2462	Ant1	2486	-35.54	-10	Pass
NVNT	n40	2462	Ant1	2487	-35.59	-10	Pass
NVNT	n40	2462	Ant1	2488	-36.18	-10	Pass
NVNT	n40	2462	Ant1	2489	-35.86	-10	Pass
NVNT	n40	2462	Ant1	2490	-36.2	-10	Pass
NVNT	n40	2462	Ant1	2491	-36.83	-10	Pass
NVNT	n40	2462	Ant1	2492	-38.52	-10	Pass
NVNT	n40	2462	Ant1	2493	-38.24	-10	Pass
NVNT	n40	2462	Ant1	2494	-38.31	-10	Pass
NVNT	n40	2462	Ant1	2495	-39.1	-10	Pass
NVNT	n40	2462	Ant1	2496	-39.73	-10	Pass
NVNT	n40	2462	Ant1	2497	-39.22	-10	Pass
NVNT	n40	2462	Ant1	2498	-39.17	-10	Pass
NVNT	n40	2462	Ant1	2499	-41.19	-10	Pass
NVNT	n40	2462	Ant1	2500	-41.5	-10	Pass

NVNT	n40	2462	Ant1	2501	-41.13	-10	Pass
NVNT	n40	2462	Ant1	2502	-41.35	-10	Pass
NVNT	n40	2462	Ant1	2503	-42.54	-10	Pass
NVNT	n40	2462	Ant1	2504	-41.92	-10	Pass
NVNT	n40	2462	Ant1	2505	-42.32	-10	Pass
NVNT	n40	2462	Ant1	2506	-43.05	-10	Pass
NVNT	n40	2462	Ant1	2507	-42.58	-10	Pass
NVNT	n40	2462	Ant1	2508	-43.05	-10	Pass
NVNT	n40	2462	Ant1	2509	-43.35	-10	Pass
NVNT	n40	2462	Ant1	2510	-43.86	-10	Pass
NVNT	n40	2462	Ant1	2511	-44.03	-10	Pass
NVNT	n40	2462	Ant1	2512	-45.8	-10	Pass
NVNT	n40	2462	Ant1	2513	-45.89	-10	Pass
NVNT	n40	2462	Ant1	2514	-46.86	-10	Pass
NVNT	n40	2462	Ant1	2515	-48.33	-10	Pass
NVNT	n40	2462	Ant1	2516	-49.68	-10	Pass
NVNT	n40	2462	Ant1	2517	-50.07	-10	Pass
NVNT	n40	2462	Ant1	2518	-50.05	-10	Pass
NVNT	n40	2462	Ant1	2519	-49.9	-10	Pass
NVNT	n40	2462	Ant1	2519.444	-49.8	-10	Pass
NVNT	n40	2462	Ant1	2520.444	-49.99	-20	Pass
NVNT	n40	2462	Ant1	2521.444	-50.24	-20	Pass
NVNT	n40	2462	Ant1	2522.444	-50.55	-20	Pass
NVNT	n40	2462	Ant1	2523.444	-50.38	-20	Pass
NVNT	n40	2462	Ant1	2524.444	-50.1	-20	Pass
NVNT	n40	2462	Ant1	2525.444	-50	-20	Pass
NVNT	n40	2462	Ant1	2526.444	-50.09	-20	Pass
NVNT	n40	2462	Ant1	2527.444	-50.22	-20	Pass
NVNT	n40	2462	Ant1	2528.444	-50.6	-20	Pass
NVNT	n40	2462	Ant1	2529.444	-50.83	-20	Pass
NVNT	n40	2462	Ant1	2530.444	-50.87	-20	Pass
NVNT	n40	2462	Ant1	2531.444	-51.04	-20	Pass
NVNT	n40	2462	Ant1	2532.444	-50.76	-20	Pass
NVNT	n40	2462	Ant1	2533.444	-50.87	-20	Pass
NVNT	n40	2462	Ant1	2534.444	-51.09	-20	Pass
NVNT	n40	2462	Ant1	2535.444	-51.12	-20	Pass
NVNT	n40	2462	Ant1	2536.444	-51.22	-20	Pass
NVNT	n40	2462	Ant1	2537.444	-51.37	-20	Pass
NVNT	n40	2462	Ant1	2538.444	-51.34	-20	Pass
NVNT	n40	2462	Ant1	2539.444	-51.46	-20	Pass
NVNT	n40	2462	Ant1	2540.444	-51.4	-20	Pass
NVNT	n40	2462	Ant1	2541.444	-51.47	-20	Pass
NVNT	n40	2462	Ant1	2542.444	-51.39	-20	Pass
NVNT	n40	2462	Ant1	2543.444	-51.35	-20	Pass
NVNT	n40	2462	Ant1	2544.444	-51.43	-20	Pass
NVNT	n40	2462	Ant1	2545.444	-51.52	-20	Pass
NVNT	n40	2462	Ant1	2546.444	-51.52	-20	Pass
NVNT	n40	2462	Ant1	2547.444	-51.53	-20	Pass
NVNT	n40	2462	Ant1	2548.444	-51.65	-20	Pass
NVNT	n40	2462	Ant1	2549.444	-51.75	-20	Pass
NVNT	n40	2462	Ant1	2550.444	-51.72	-20	Pass
NVNT	n40	2462	Ant1	2551.444	-51.86	-20	Pass
NVNT	n40	2462	Ant1	2552.444	-51.87	-20	Pass
NVNT	n40	2462	Ant1	2553.444	-51.87	-20	Pass
NVNT	n40	2462	Ant1	2554.444	-51.85	-20	Pass
NVNT	n40	2462	Ant1	2555.444	-51.89	-20	Pass
NVNT	n40	2462	Ant1	2555.888	-51.83	-20	Pass

Tx. Emissions OOB NVNT b 2412MHz Ant1

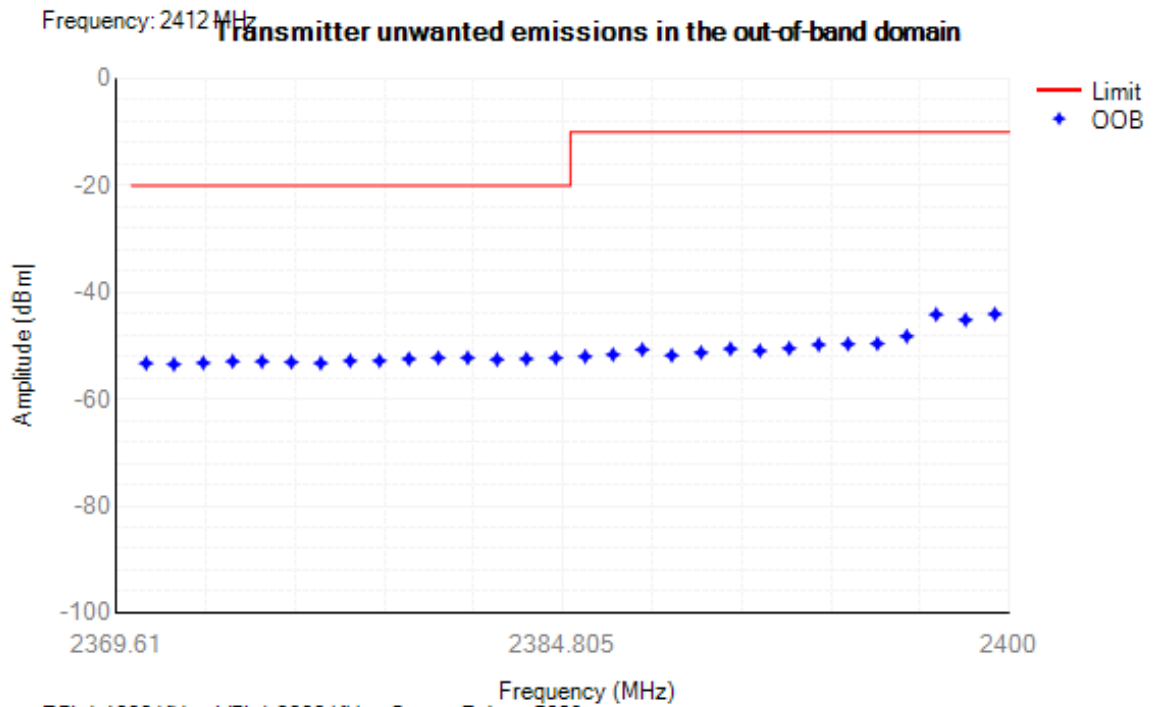

RBW: 1000 KHz, VBW: 3000 KHz, Sweep Points: 5029

Tx. Emissions OOB NVNT b 2472MHz Ant1

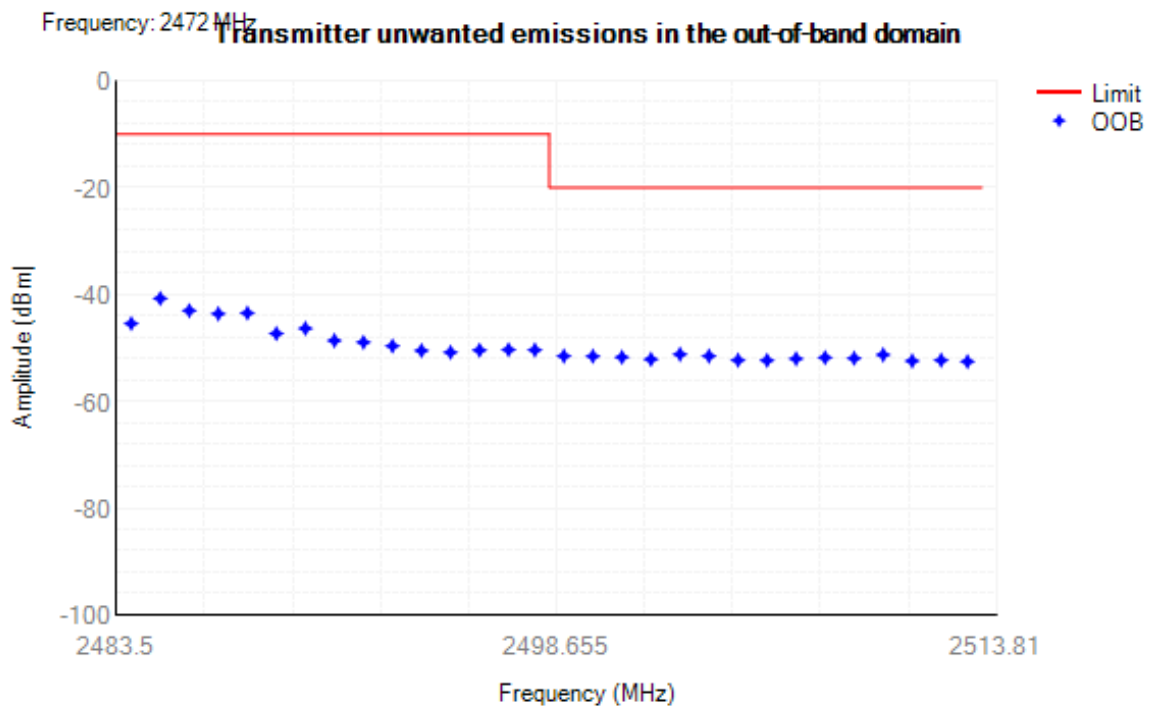

RBW: 1000 KHz, VBW: 3000 KHz, Sweep Points: 5029

Tx. Emissions OOB NVNT g 2412MHz Ant1

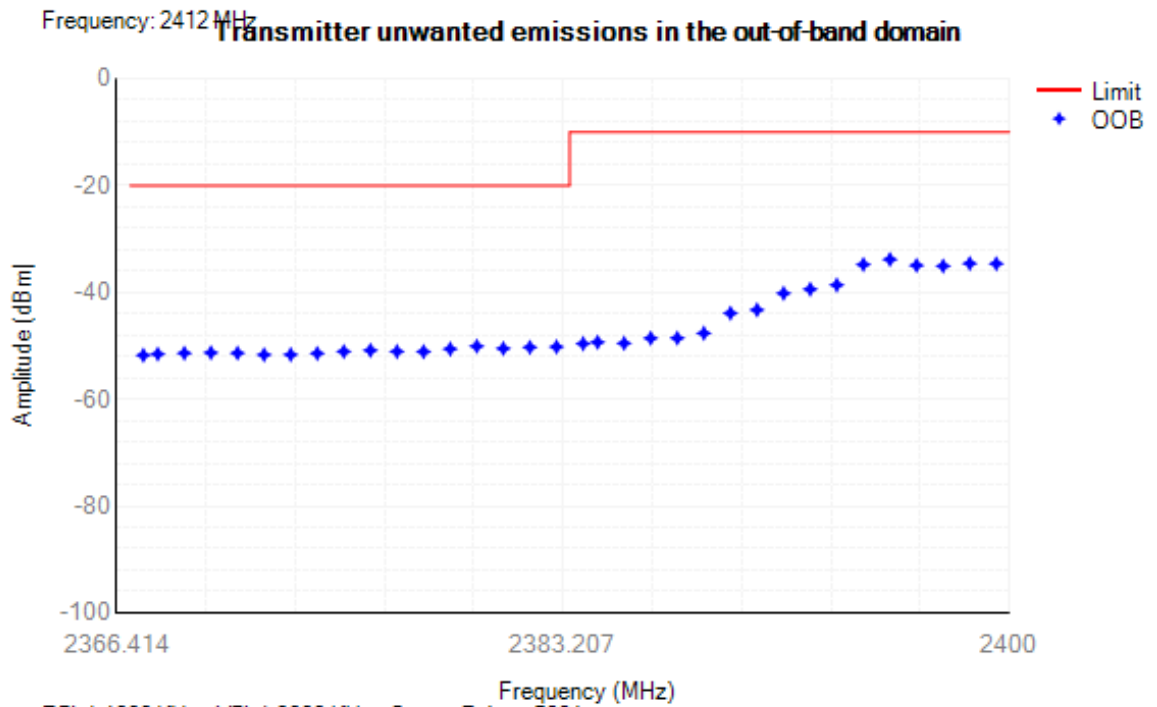

Tx. Emissions OOB NVNT g 2472MHz Ant1

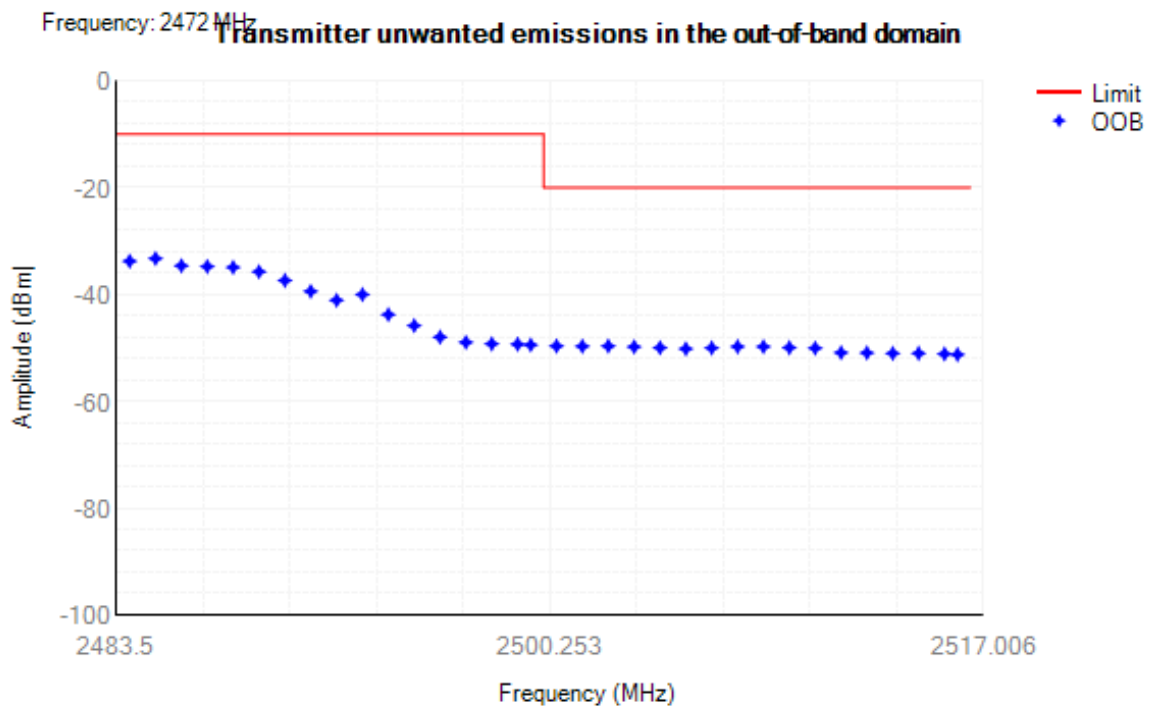

Tx. Emissions OOB NVNT n20 2412MHz Ant1

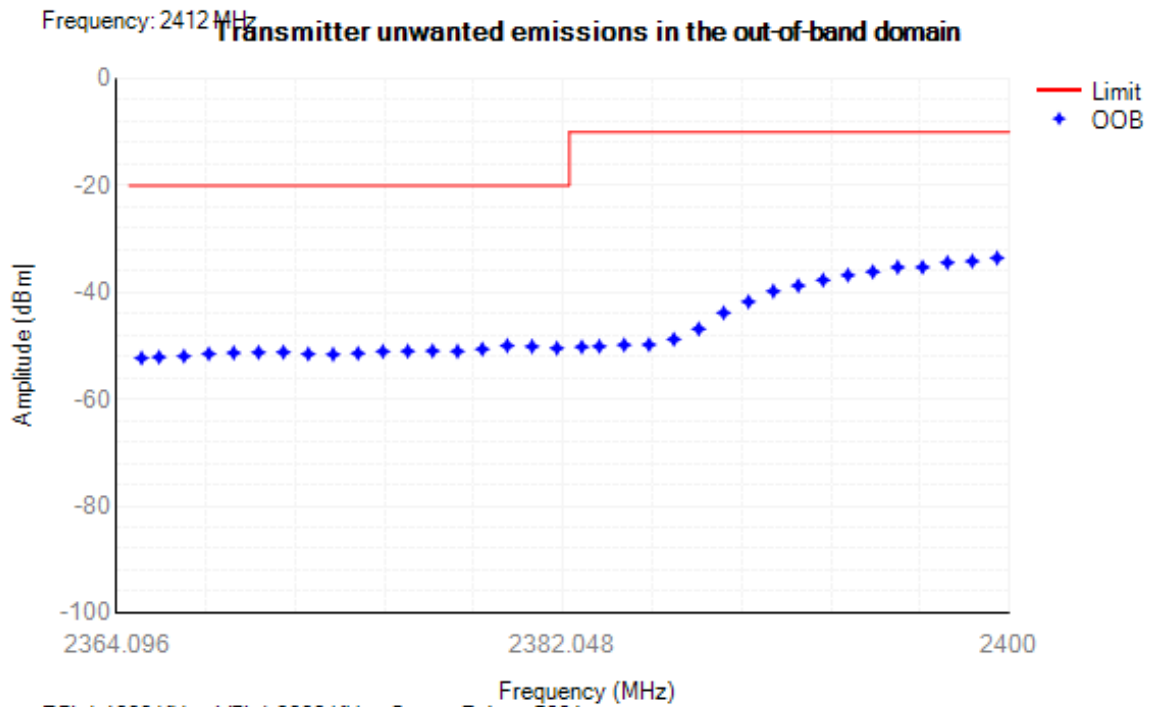

RBW: 1000 KHz, VBW: 3000 KHz, Sweep Points: 5001

Tx. Emissions OOB NVNT n20 2472MHz Ant1

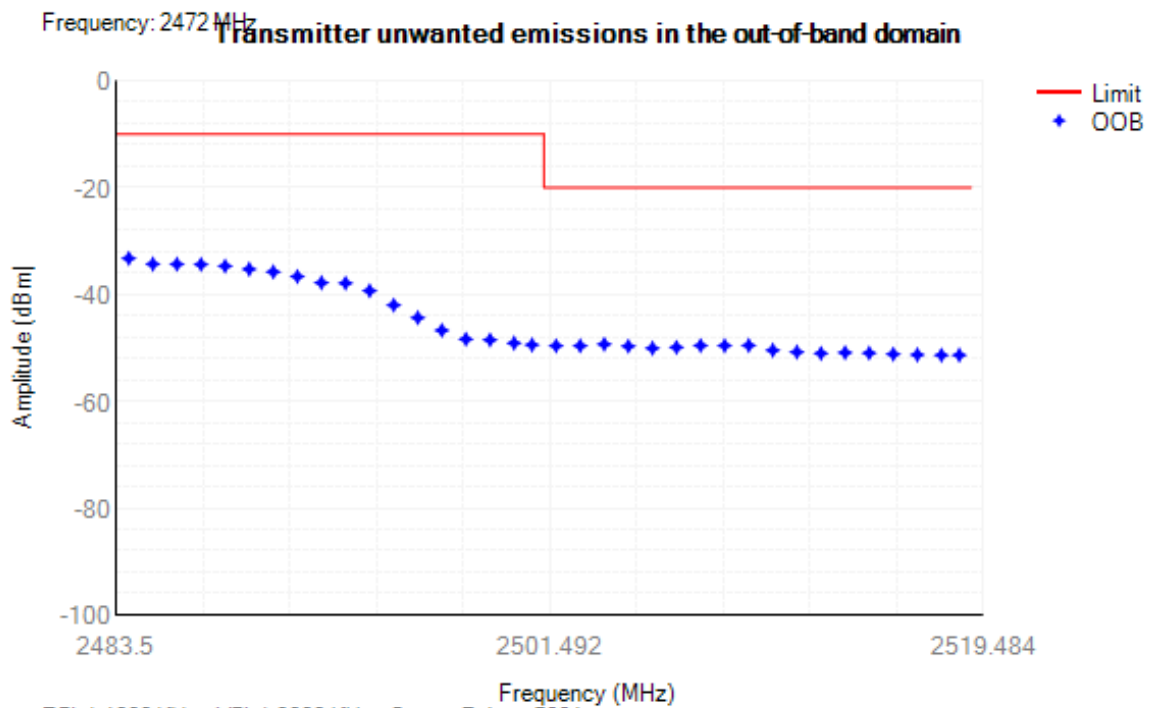

RBW: 1000 KHz, VBW: 3000 KHz, Sweep Points: 5001

Tx. Emissions OOB NVNT n40 2422MHz Ant1

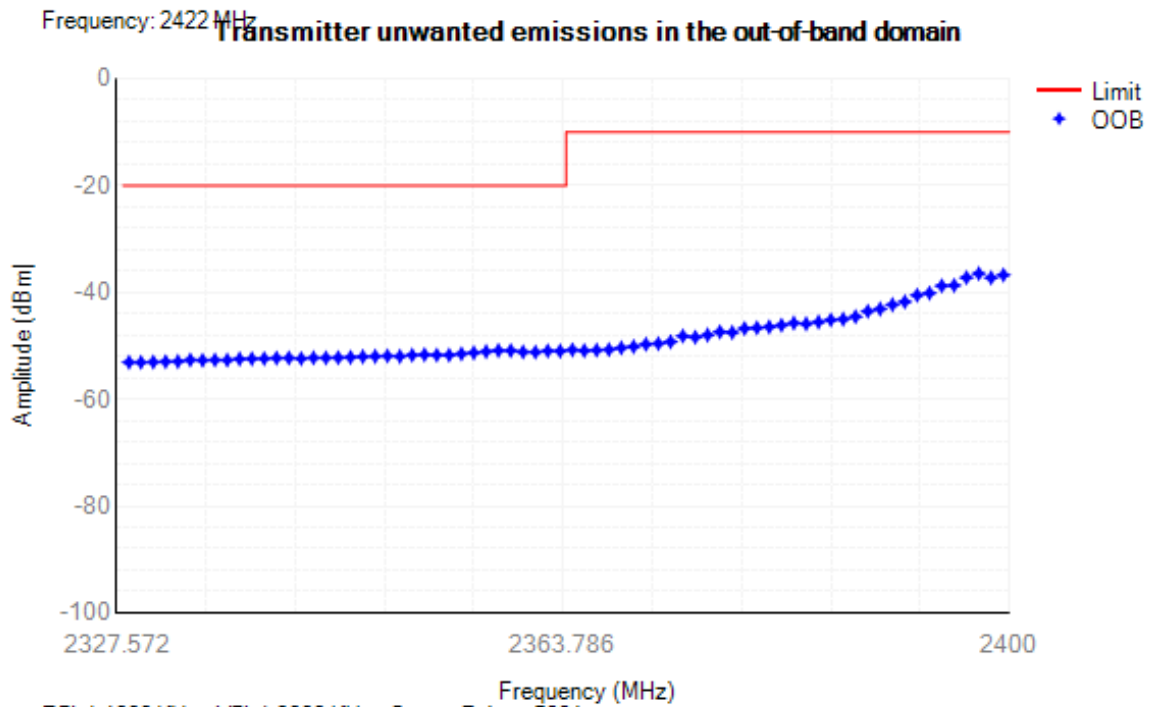

RBW: 1000 KHz, VBW: 3000 KHz, Sweep Points: 5001

Tx. Emissions OOB NVNT n40 2462MHz Ant1

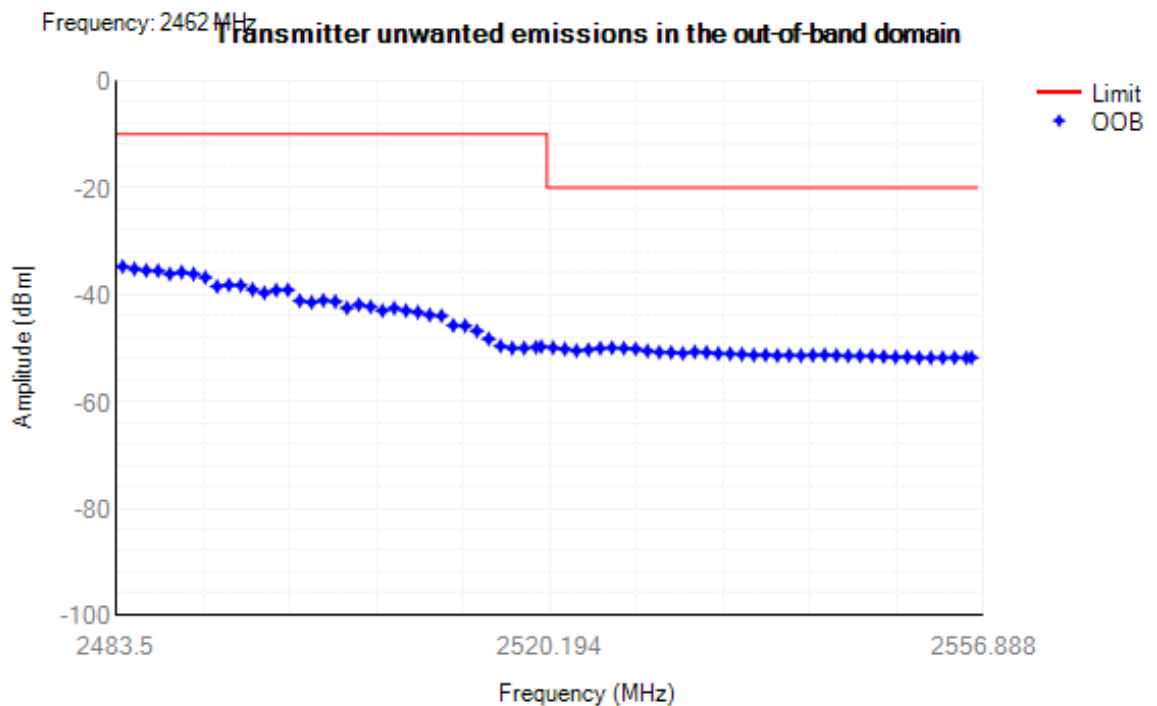

RBW: 1000 KHz, VBW: 3000 KHz, Sweep Points: 5001

8. Transmitter unwanted emissions in the spurious domain

8.1. Limit

The transmitter unwanted emissions in the spurious domain shall not exceed the values given in following table .

Frequency range	Maximum power, e.r.p. (≤ 1 GHz) e.i.r.p. (> 1 GHz)	Bandwidth
30 MHz to 47 MHz	-36 dBm	100 kHz
47 MHz to 74 MHz	-54 dBm	100 kHz
74 MHz to 87,5 MHz	-36 dBm	100 kHz
87,5 MHz to 118 MHz	-54 dBm	100 kHz
118 MHz to 174 MHz	-36 dBm	100 kHz
174 MHz to 230 MHz	-54 dBm	100 kHz
230 MHz to 470 MHz	-36 dBm	100 kHz
470 MHz to 694 MHz	-54 dBm	100 kHz
694 MHz to 1 GHz	-36 dBm	100 kHz
1 GHz to 12,75 GHz	-30 dBm	1 MHz

8.2. Test Procedure

Refer to ETSI EN 300 328 V2.2.2:2019 Clause 5.4.9.

8.3. Test Result

Test Mode: IEEE 802.11b Tx in CH1 2412MHz					
Frequency (MHz)	Antenna polarization	Result (dBm)	Limit (dBm)	Margin (dB)	Conclusion
243.06	H	-58.16	-36	-22.16	Pass
494.89	H	-66.27	-54	-12.27	Pass
4824.07	H	-55.51	-30	-25.51	Pass
7236.17	H	-62.12	-30	-32.12	Pass
275.31	V	-56.89	-36	-20.89	Pass
503.24	V	-63.35	-54	-9.35	Pass
4823.95	V	-58.37	-30	-28.37	Pass
7235.95	V	-58.13	-30	-28.13	Pass
Test Mode: IEEE 802.11b Tx in CH13 2472MHz					
235.75	H	-58.10	-36	-22.10	Pass
495.06	H	-66.53	-54	-12.53	Pass
4944.07	H	-62.67	-30	-32.67	Pass
7416.09	H	-64.78	-30	-34.78	Pass
271.45	V	-59.77	-36	-23.77	Pass
507.54	V	-59.10	-54	-5.10	Pass
4943.96	V	-67.27	-30	-37.27	Pass
7415.94	V	-68.40	-30	-38.40	Pass

Test Mode: IEEE 802.11g Tx in CH1 2412MHz					
Frequency (MHz)	Antenna polarization	Result (dBm)	Limit (dBm)	Margin (dB)	Conclusion
251.60	H	-54.62	-36	-18.62	Pass
485.99	H	-65.06	-54	-11.06	Pass
4824.01	H	-55.72	-30	-25.72	Pass
7235.94	H	-61.98	-30	-31.98	Pass
277.94	V	-58.51	-36	-22.51	Pass
505.48	V	-64.59	-54	-10.59	Pass
4824.07	V	-54.29	-30	-24.29	Pass
7236.05	V	-59.30	-30	-29.30	Pass
Test Mode: IEEE 802.11g Tx in CH13 2472MHz					
243.91	H	-62.20	-36	-26.20	Pass
497.57	H	-67.86	-54	-13.86	Pass
4944.01	H	-51.20	-30	-21.20	Pass
7415.98	H	-57.31	-30	-27.31	Pass
271.57	V	-57.00	-36	-21.00	Pass
510.99	V	-61.39	-54	-7.39	Pass
4943.95	V	-54.61	-30	-24.61	Pass
7416.06	V	-59.93	-30	-29.93	Pass

Test Mode: IEEE 802.11nHT20 Tx in CH1 2412MHz					
Frequency (MHz)	Antenna polarization	Result (dBm)	Limit (dBm)	Margin (dB)	Conclusion
243.20	H	-63.63	-36	-27.63	Pass
481.94	H	-63.69	-54	-9.69	Pass
4824.09	H	-56.98	-30	-26.98	Pass
7235.93	H	-62.01	-30	-32.01	Pass
268.30	V	-53.97	-36	-17.97	Pass
512.38	V	-61.57	-54	-7.57	Pass
4824.16	V	-61.31	-30	-31.31	Pass
7236.01	V	-68.18	-30	-38.18	Pass
Test Mode: IEEE 802.11nHT20 Tx in CH13 2472MHz					
246.98	H	-61.44	-36	-25.44	Pass
501.10	H	-66.82	-54	-12.82	Pass
4944.05	H	-61.98	-30	-31.98	Pass
7416.04	H	-55.69	-30	-25.69	Pass
271.51	V	-55.08	-36	-19.08	Pass
497.55	V	-60.07	-54	-6.07	Pass
4943.95	V	-60.94	-30	-30.94	Pass
7415.92	V	-64.31	-30	-34.31	Pass

Test Mode: IEEE 802.11nHT40 Tx in CH3 2422MHz					
Frequency (MHz)	Antenna polarization	Result (dBm)	Limit (dBm)	Margin (dB)	Conclusion
263.35	H	-57.36	-36	-21.36	Pass
480.21	H	-69.97	-54	-15.97	Pass
4844.04	H	-54.51	-30	-24.51	Pass
7265.92	H	-63.40	-30	-33.40	Pass
278.96	V	-61.20	-36	-25.20	Pass
509.99	V	-64.88	-54	-10.88	Pass
4844.02	V	-66.20	-30	-36.20	Pass
7235.92	V	-59.27	-30	-29.27	Pass
Test Mode: IEEE 802.11nHT40 Tx in CH11 2462MHz					
235.29	H	-53.35	-36	-17.35	Pass
499.63	H	-63.17	-54	-9.17	Pass
4924.08	H	-59.91	-30	-29.91	Pass
7386.05	H	-61.32	-30	-31.32	Pass
272.60	V	-55.96	-36	-19.96	Pass
503.65	V	-58.84	-54	-4.84	Pass
4923.97	V	-55.43	-30	-25.43	Pass
7386.06	V	-67.72	-30	-37.72	Pass

9. Receiver Spurious emissions

9.1. Limit

The spurious emissions of the receiver shall not exceed the values given in following table .

Frequency range	Maximum power, e.r.p. (≤ 1 GHz) e.i.r.p. (> 1 GHz)	Bandwidth
30 MHz to 1GHz	-57 dBm	100 kHz
1 GHz to 12,75 GHz	-47 dBm	1 MHz

9.2. Test Procedure

Refer to ETSI EN 300 328 V2.2.2:2019 Clause 5.4.10.

9.3. Test Result

Test Mode: IEEE 802.11b Rx in CH1 2412MHz					
Frequency (MHz)	Antenna polarization	Result (dBm)	Limit (dBm)	Margin (dB)	Conclusion
238.61	H	-67.57	-57	-10.57	Pass
585.88	H	-63.58	-57	-6.58	Pass
2013.39	H	-59.26	-47	-12.26	Pass
2397.57	H	-65.10	-47	-18.10	Pass
219.16	V	-63.43	-57	-6.43	Pass
597.73	V	-58.43	-57	-1.43	Pass
2018.96	V	-66.63	-47	-19.63	Pass
2388.26	V	-58.45	-47	-11.45	Pass
Test Mode: IEEE 802.11b Rx in CH13 2472MHz					
254.80	H	-68.42	-57	-11.42	Pass
607.20	H	-69.08	-57	-12.08	Pass
2034.67	H	-61.40	-47	-14.40	Pass
2410.87	H	-60.32	-47	-13.32	Pass
215.94	V	-63.73	-57	-6.73	Pass
617.26	V	-63.72	-57	-6.72	Pass
2029.28	V	-67.50	-47	-20.50	Pass
2405.35	V	-62.49	-47	-15.49	Pass

10. Receiver Blocking

10.1. Limit

While maintaining the minimum performance criteria as defined in clause 4.3.2.11.3, the blocking levels at specified frequency offsets shall be equal to or greater than the limits defined for the applicable receiver category provided in table 14, table 15 or table 16.

Table 14: Receiver Blocking parameters for Receiver Category 1 equipment

Wanted signal mean power from companion device (dBm) (see notes 1 and 4)	Blocking signal frequency (MHz)	Blocking signal power (dBm) (see note 4)	Type of blocking signal
$(-133 \text{ dBm} + 10 \times \log_{10}(\text{OCBW}))$ or -68 dBm whichever is less (see note 2)	2380 2504	-34	CW
$(-139 \text{ dBm} + 10 \times \log_{10}(\text{OCBW}))$ or -74 dBm whichever is less (see note 3)	2 300 2 330 2 360 2 524 2 584 2 674		
<p>NOTE 1: OCBW is in Hz.</p> <p>NOTE 2: In case of radiated measurements using a companion device and the level of the wanted signal from the companion device cannot be determined, a relative test may be performed using a wanted signal up to $P_{\text{min}} + 26 \text{ dB}$ where P_{min} is the minimum level of wanted signal required to meet the minimum performance criteria as defined in clause 4.3.1.12.3 in the absence of any blocking signal.</p> <p>NOTE 3: In case of radiated measurements using a companion device and the level of the wanted signal from the companion device cannot be determined, a relative test may be performed using a wanted signal up to $P_{\text{min}} + 20 \text{ dB}$ where P_{min} is the minimum level of wanted signal required to meet the minimum performance criteria as defined in clause 4.3.1.12.3 in the absence of any blocking signal.</p> <p>NOTE 4: The level specified is the level at the UUT receiver input assuming a 0 dBi antenna assembly gain. In case of conducted measurements, this level has to be corrected for the (in-band) antenna assembly gain (G). In case of radiated measurements, this level is equivalent to a power flux density (PFD) in front of the UUT antenna with the UUT being configured/positioned as recorded in clause 5.4.3.2.2.</p>			

Table 15: Receiver Blocking parameters receiver Category 2 equipment

Wanted signal mean power from companion device (dBm) (see notes 1 and 4)	Blocking signal frequency (MHz)	Blocking signal power (dBm) (see note 4)	Type of blocking signal
$(-139 \text{ dBm} + 10 \times \log_{10}(\text{OCBW}) + 10 \text{ dB})$ or $(-74 + 10 \text{ dB}) \text{ dBm}$ whichever is less (see note 2)	2 380 2 504 2 300 2 584	-34	CW
<p>NOTE 1: OCBW is in Hz.</p> <p>NOTE 2: In case of radiated measurements using a companion device and the level of the wanted signal from the companion device cannot be determined, a relative test may be performed using a wanted signal up to $P_{\text{min}} + 26 \text{ dB}$ where P_{min} is the minimum level of wanted signal required to meet the minimum performance criteria as defined in clause 4.3.1.12.3 in the absence of any blocking signal.</p> <p>NOTE 3: The level specified is the level at the UUT receiver input assuming a 0 dBi antenna assembly gain. In case of conducted measurements, this level has to be corrected for the (in-band) antenna assembly gain (G). In case of radiated measurements, this level is equivalent to a power flux density (PFD) in front of the UUT antenna with the UUT being configured/positioned as recorded in clause 5.4.3.2.2.</p>			

Table 16: Receiver Blocking parameters receiver Category 3 equipment

Wanted signal mean power from companion device (dBm) (see notes 1 and 4)	Blocking signal frequency (MHz)	Blocking signal power (dBm) (see note 4)	Type of blocking signal
(-139 dBm + 10 × log ₁₀ (OCBW) + 20 dB) or (-74+ 20 dB) dBm whichever is less (see note 2)	2 380 2 504 2 300 2 584	-34	CW

NOTE 1: OCBW is in Hz.
NOTE 2: In case of radiated measurements using a companion device and the level of the wanted signal from the companion device cannot be determined, a relative the test may be performed using a wanted signal up to P_{min} + 30 dB where P_{min} is the minimum level of wanted signal required to meet the minimum performance criteria as defined in clause 4.3.1.12.3 in the absence of any blocking signal.
NOTE 3: The level specified is the level at the UUT receiver input assuming a 0 dBi antenna assembly gain. In case of conducted measurements, this level has to be corrected for the (in-band) antenna assembly gain (G). In case of radiated measurements, this level is equivalent to a power flux density (PFD) in front of the UUT antenna with the UUT being configured/positioned as recorded in clause 5.4.3.2.2.

10.2. Test Setup

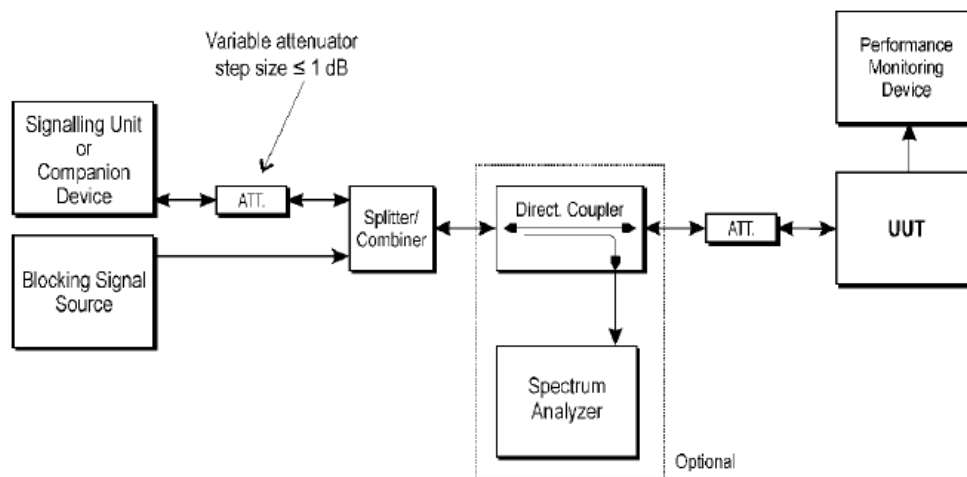

10.3. Test Procedure

Refer to ETSI EN 300 328 V2.2.2:2019 Clause 5.4.11.

10.4. Test Result

Wanted signal mean power from companion device (dBm)	Channel frequency (MHz)	Blocking signal frequency (MHz)	Blocking signal power (dBm)	PER (%)	PER limit
-68	2412	2380	-34	1.0	≤10%
	2412	2504		1.6	≤10%
-74	2412	2300		1.3	≤10%
	2412	2330		0.8	≤10%
	2412	2360		1.0	≤10%
	2412	2524		0.9	≤10%
	2412	2584		1.2	≤10%
	2412	2674		0.6	≤10%
-68	2472	2380	-34	1.3	≤10%
	2472	2504		1.1	≤10%
-74	2472	2300		1.1	≤10%
	2472	2330		1.0	≤10%
	2472	2360		1.2	≤10%
	2472	2524		1.5	≤10%
	2472	2584		1.3	≤10%
	2472	2674		1.0	≤10%
Test result: PASS					
Note:					
1. The equipment belongs to receiver category 1 and it shall be tested operating at lowest data transmitting speed, Lowest channel and highest channel.					
2. For 2380MHz,2504MHz:Wanted signal mean power(dBm)= (-133dBm + 10 × log10(OCBW)) or (-68 dBm) whichever is less For all blocking signal frequency other than 2380MHz,2504MHz: Wanted signal mean power(dBm)= (-139 dBm + 10 × log10(OCBW)) or (-74 dBm) whichever is less					
3. When required blocking signals injected, communication link between the UUT and the associated companion device remains, and the performance still meet the minimum performance criterion PER≤10%.					

11. Geo-location capability

11.1. Definition

Geo-location capability is a feature of the equipment to determine its geographical location with the purpose to configure itself according to the regulatory requirements applicable at the geographical location where it operates.

The geo-location capability may be present in the equipment or in an external device (temporary) associated with the equipment operating at the same geographical location during the initial power up of the equipment. The geographical location may also be available in equipment already installed and operating at the same geographical location.

11.2. Requirements

The geographical location determined by the equipment shall not be accessible to the user.

11.3. Test Result

Not apply.

This requirement only applies to equipment with geo-location capability. And this product does not have the Geo-location capability, thus, not apply to this product.

12. Photos of test setup



13. Photos of EUT

Please refer to the report A2503316-C01-R01.

14. Model list

YG691	YG231	YG281	YG291	YG351	YG331
YG361	YG371	YG381	YG391	YG411	YG421
YG431	YG461	YG471	YG491	YG551	YG561
YG581	YG591	YG621	YG621miniYG631	YG651	YG661
YG681	YG721	YG731	YG751	YG761	YG771
YG781	YG791	YG280	YG290	YG330	YG350
YG360	YG370	YG380	YG390	YG420	YG430
YG470	YG490	YG550	YG560	YG600	YG600Plus
YG620mini	YG650	YG680	YG690	YG720	YG730
YG750	YG760	YG770	YG780	YG790	W1K
.YG201	YG203	YG210	YG211	YG213	YG221
YG223	YG233	YG241	YG243	YG251	YG253
YG261	YG263	YG271	YG273	YG283	YG293
YG301	YG303	YG311	YG313	YG321	YG323
YG333	YG341	YG343	YG351	YG353	YG363
YG373	YG383	YG393	YG401	YG403	YG413
YG423	YG433	YG441	YG443	YG451	YG453
YG463	YG473	YG481	YG483	YG493	YG501
YG501	YG511	YG513	YG521	YG523	YG531
YG533	YG541	YG543	YG553	YG563	YG571
YG573	YG583	YG593			

-----END OF REPORT-----